

ROTEC®

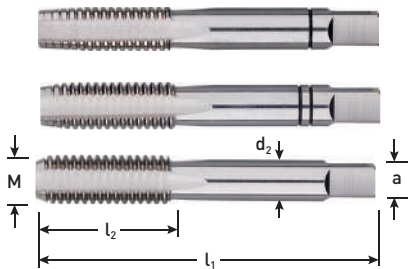

Draadsnijden
en draadreparatie

Uitvoering: HSS handtappensets, DIN 352, metrisch [M].
Set à 3 stuks bestaande uit 1x voorsnijder, middensnijder en nasnijder.



M	p	l ₁	l ₂	d ₂	a	St./VE	Art.nr.	€ / VE
2	0,4	36	8	2,8	2,1	1	300.0200	25,78
3	0,5	40	11	3,5	2,7	1	300.0300	10,04
3,5	0,6	45	13	4,0	3,0	1	300.0350	23,14
4	0,7	45	13	4,5	3,4	1	300.0400	10,74
4,5	0,75	50	16	6,0	4,9	1	300.0450	22,21
5	0,8	50	16	6,0	4,9	1	300.0500	11,47
6	1,0	50	19	6,0	4,9	1	300.0600	11,47
7	1,0	50	19	6,0	4,9	1	300.0700	26,51
8	1,25	56	22	6,0	4,9	1	300.0800	15,05
9	1,25	63	22	7,0	5,5	1	300.0900	37,03
10	1,5	70	24	7,0	5,5	1	300.1000	18,27
11	1,5	70	24	8,0	6,2	1	300.1100	49,60
12	1,75	75	29	9,0	7,0	1	300.1200	22,92
14	2,0	80	30	11,0	9,0	1	300.1400	28,30

M	p	l ₁	l ₂	d ₂	a	St./VE	Art.nr.	€ / VE
16	2,0	80	32	12,0	9,0	1	300.1600	36,52
18	2,5	95	40	14,0	11,0	1	300.1800	50,49
20	2,5	95	40	16,0	12,0	1	300.2000	54,09
22	2,5	100	40	18,0	14,5	1	300.2200	73,04
24	3,0	110	50	18,0	14,5	1	300.2400	85,97
27	3,0	110	50	20,0	16,0	1	300.2700	206,11
30	3,5	125	56	22,0	18,0	1	300.3000	268,56
33	3,5	125	56	25,0	20,0	1	300.3300	356,91
36	4,0	150	63	28,0	22,0	1	300.3600	399,03
39	4,0	150	63	32,0	24,0	1	300.3900	515,42
42	4,5	150	63	32,0	24,0	1	300.4200	582,26
45	4,5	160	70	36,0	29,0	1	300.4500	706,61
48	5,0	180	75	36,0	29,0	1	300.4800	997,59
52	5,0	180	75	40,0	32,0	1	300.5200	997,59

HSS Handtappenset, metrisch [M], in ABS-cassette



Uitvoering: HSS handtappensets, DIN 352, metrisch [M].
Elke maat is een set à 3 stuks bestaande uit 1x voorsnijder, middensnijder en nasnijder.

Omschrijving	Type	Inhoud	St./VE	Art.nr.	€ / VE
21-dlg. (7x3) set handtappen	300	1x handtappenset M3 - M4 - M5 - M6 - M8 - M10 en M12	1	900.2000	134,01

HSS Handtappen- en borenset, metrisch [M], in ABS-cassette



Uitvoering: HSS handtappensets, DIN 352, metrisch [M] met bijbehorende HSS kerngatboren.
Elke tapmaat is een set à 3 stuks bestaande uit 1x voorsnijder, middensnijder en nasnijder.

Omschrijving	Type	Inhoud	St./VE	Art.nr.	€ / VE
28-dlg. set handtappen en boren	300 101	1x handtappenset M3 - M4 - M5 - M6 - M8 - M10 en M12 1x spiraalboor ø2,5 - 3,3 - 4,2 - 5,0 - 6,8 - 8,5 en 10,2	1	900.2002K	160,33

Handtap- en snijplaatset, metrisch [M], in kunststof koffer

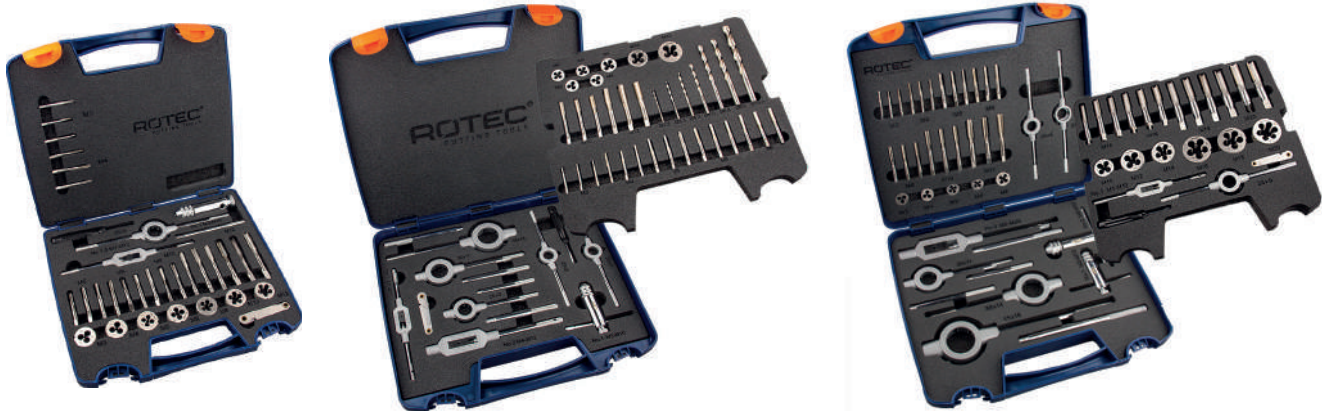

Omschrijving	Inhoud	St./VE	Art.nr.	€ / VE
33-dlg. handtappen- en snijplaatenset	1x tappenset (3-dlg.) M3, M4, M5, M6, M8, M10 en M12 1x snijplaat M3, M4, M5, M6, M8, M10 en M12 1x tapkruk nr.1 1x snijplaathouder 25x9 1x wringijzer nr. 1½ 1x draadmeter (metrisch) 1x schroevendraaier	1	900.2010K	215,12
45-dlg. handtappen- en snijplaatenset	1x tappenset (3-dlg.) M3, M4, M5, M6, M8, M10 en M12 1x snijplaat M3, M4, M5, M6, M8, M10 en M12 1x boor ø2,5 - 3,3 - 4,2 - 5,0 - 6,8 - 8,5 - 10,2 mm 1x snijplaathouder 20x5, 20x7, 25x9, 30x11, 38x14 1x wringijzer nr. 1 en 2 1x draadmeter (metrisch) 1x tapkruk 1x schroevendraaier	1	900.2020K	254,65
55-dlg. handtappen- en snijplaatenset	1x tappenset (3-dlg.) M3, M4, M5, M6, M8, M10, M12, M14, M16, M18 en M20 1x snijplaat M3, M4, M5, M6, M8, M10, M12, M14, M16, M18 en M20 1x tapkruk nr.1 en 2 1x snijplaathouder 20x5, 20x7, 25x9, 30x11, 38x14, 45x18 1x wringijzer nr. 1 en 3 1x draadmeter (metrisch) 1x schroevendraaier	1	900.2022K	589,68

Draadsnijset, metrisch [M], in kunststof koffer



Omschrijving	Inhoud	St./VE	Art.nr.	€ / VE
26-dlg. tappen-, boren- en snijplaatenset	1x tap M3, M4, M5, M6, M8, M10 en M12 1x snijplaat M3, M4, M5, M6, M8, M10 en M12 1x boor ø2,5 - 3,3 - 4,2 - 5,0 - 6,8 - 8,5 - 10,2 mm 1x tapkruk nr.1 1x snijplaathouder 25x9 1x wringijzer nr.2 1x draadmeter (metrisch) 1x schroevendraaier	1	900.2026	170,84

301

HSS-E Handtappenset, metrisch [M]

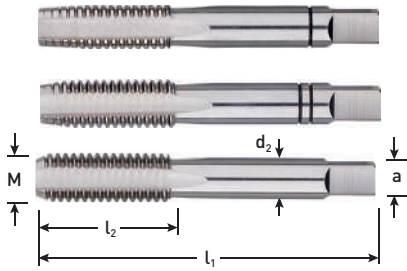

Uitvoering: HSS-E handtappensets, DIN 352, metrisch, sets à 3 stuks. Slijtvastere tap met langere levensduur dan HSS.

Toepassing: Het gelegerde basismateriaal maakt deze handtap bij uitstek geschikt voor de moeilijk te verspanen materiaalsoorten zoals hooggeleerd staal en RVS.

M	p	l ₁	l ₂	d ₂	a	St./VE	Art.nr.	€ / VE
3	0,5	40	11	3,5	2,7	1	301.0300	28,94
4	0,7	45	13	4,5	3,4	1	301.0400	31,07
5	0,8	50	16	6,0	4,9	1	301.0500	31,07
6	1,0	50	19	6,0	4,9	1	301.0600	33,22
8	1,25	56	22	6,0	4,9	1	301.0800	37,50
10	1,5	70	24	7,0	5,5	1	301.1000	52,51
12	1,75	75	29	9,0	7,0	1	301.1200	63,22
14	2,0	80	30	11,0	9,0	1	301.1400	89,99

M	p	l ₁	l ₂	d ₂	a	St./VE	Art.nr.	€ / VE
16	2,0	80	32	12,0	9,0	1	301.1600	132,86
18	2,5	95	40	14,0	11,0	1	301.1800	152,41
20	2,5	95	40	16,0	12,0	1	301.2000	165,71
22	2,5	100	40	18,0	14,5	1	301.2200	213,26
24	3,0	110	50	18,0	14,5	1	301.2400	285,46
27	3,0	110	50	20,0	16,0	1	301.2700	507,94
30	3,5	125	56	22,0	18,0	1	301.3000	587,55

305

HSS Handtappenset, metrisch fijn [MF]

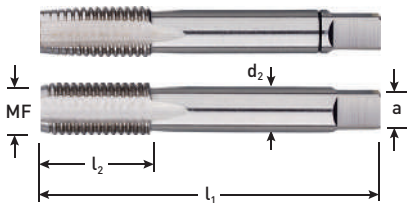

Uitvoering: HSS handtappensets, DIN 2181, metrisch fijn, sets à 2 stuks.

MF	p	l ₁	l ₂	d ₂	a	St./VE	Art.nr.	€ / VE
3	0,35	40	9	3,5	2,7	1	305.0303	32,28
4	0,35	45	10	4,5	3,4	1	305.0403	32,28
4	0,5	45	10	4,5	3,4	1	305.0405	33,64
5	0,5	50	12	6,0	4,9	1	305.0505	32,28
6	0,5	50	14	6,0	4,9	1	305.0605	32,28
6	0,75	50	14	6,0	4,9	1	305.0607	30,27
8	0,5	50	19	6,0	4,9	1	305.0805	30,27
8	0,75	50	19	6,0	4,9	1	305.0807	26,41
8	1,0	56	22	6,0	4,9	1	305.0810	26,41
10	0,75	63	20	7,0	5,5	1	305.1007	32,28
10	1,0	63	20	7,0	5,5	1	305.1010	26,41
10	1,25	70	24	7,0	5,5	1	305.1012	29,34
12	0,75	70	22	9,0	7,0	1	305.1207	41,95
12	1,0	70	22	9,0	7,0	1	305.1210	38,15
12	1,25	70	22	9,0	7,0	1	305.1212	38,15
12	1,5	70	22	9,0	7,0	1	305.1215	35,21
14	1,0	70	22	11,0	9,0	1	305.1410	64,55
14	1,25	70	22	11,0	9,0	1	305.1412	44,27

MF	p	l ₁	l ₂	d ₂	a	St./VE	Art.nr.	€ / VE
14	1,5	70	22	11,0	9,0	1	305.1415	38,15
16	1,0	70	22	12,0	9,0	1	305.1610	71,59
16	1,5	70	22	12,0	9,0	1	305.1615	46,95
18	1,0	80	22	14,0	11,0	1	305.1810	80,71
18	1,5	80	22	14,0	11,0	1	305.1815	53,35
18	2,0	80	22	14,0	11,0	1	305.1820	77,46
20	1,0	80	22	16,0	12,0	1	305.2010	97,42
20	1,5	80	22	16,0	12,0	1	305.2015	65,08
20	2,0	80	22	16,0	12,0	1	305.2020	97,42
22	1,5	80	22	18,0	14,5	1	305.2215	91,75
22	2,0	80	22	18,0	14,5	1	305.2220	100,92
24	1,5	90	22	18,0	14,5	1	305.2415	104,87
24	2,0	90	22	18,0	14,5	1	305.2420	134,96
25	1,5	90	22	18,0	14,5	1	305.2515	207,89
27	1,5	90	22	20,0	16,0	1	305.2715	199,51
27	2,0	90	22	20,0	16,0	1	305.2720	234,73
30	1,5	90	22	22,0	18,0	1	305.3015	275,80
30	2,0	90	22	22,0	18,0	1	305.3020	287,38

Uitvoering: HSS handtappensets, DIN 352, Withworth, sets à 3 stuks.

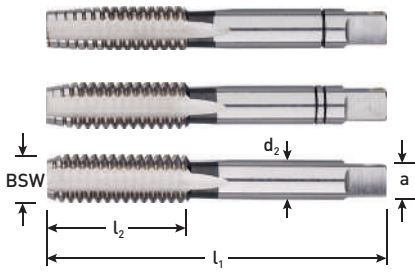

BSW	P	l ₁	l ₂	d ₂	a	St./VE	Art.nr.	€/VE
3/32	48	36	10	2,8	2,1	1	306.0002	35,20
1/8	40	40	12	3,5	2,7	1	306.0004	32,55
5/32	32	45	14	4,5	3,4	1	306.0006	31,24
3/16	24	50	18	6,0	4,9	1	306.0008	31,24
7/32	24	50	18	6,0	4,9	1	306.0010	32,55
1/4	20	50	19	6,0	4,9	1	306.0012	32,55
5/16	18	56	22	6,0	4,9	1	306.0014	34,33
3/8	16	70	24	7,0	5,5	1	306.0016	40,37
7/16	14	70	24	8,0	6,2	1	306.0018	48,41
1/2	12	75	29	9,0	7,0	1	306.0020	58,08
9/16	12	80	30	11,0	9,0	1	306.0022	75,69
5/8	11	80	32	12,0	9,0	1	306.0024	86,27
3/4	10	95	40	14,0	11,0	1	306.0026	114,43
7/8	9	100	40	18,0	14,5	1	306.0028	160,50
1	8	110	50	18,0	14,5	1	306.0030	176,04

Uitvoering: HSS handtappensets, DIN 2181, BSF, sets à 2 stuks.

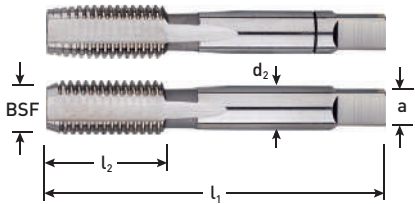

BSF	P	l ₁	l ₂	d ₂	a	St./VE	Art.nr.	€/VE
3/16	32	50	14	6,0	4,9	1	306.1010	26,31
1/4	26	50	18	6,0	4,9	1	306.1014	25,25
5/16	22	56	22	6,0	4,9	1	306.1016	27,74
3/8	20	63	22	7,0	5,5	1	306.1018	32,59
7/16	18	63	22	8,0	6,2	1	306.1020	39,12
1/2	16	75	24	9,0	7,0	1	306.1022	46,95
9/16	15	80	28	11,0	9,0	1	306.1024	61,17
5/8	14	80	28	12,0	9,0	1	306.1026	69,70
3/4	12	95	32	14,0	11,0	1	306.1030	92,46
7/8	11	100	36	18,0	14,5	1	306.1034	124,48
1	10	110	40	18,0	14,5	1	306.1038	142,25

307

HSS Handtappenset, Unified National Coarse [UNC]

Uitvoering: HSS handtappensets, DIN 352, UNC, sets à 3 stuks.

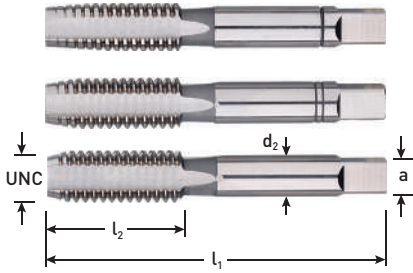

UNC	P	l_1	l_2	d_2	a	St./VE	Art.nr.	€ / VE
1/4	20	50	19	6,0	4,9	1	307.0014	31,56
5/16	18	56	22	6,0	4,9	1	307.0016	36,14
3/8	16	70	24	7,0	5,5	1	307.0018	40,76
7/16	14	70	24	8,0	6,2	1	307.0020	50,95
1/2	13	75	29	9,0	7,0	1	307.0022	58,69
9/16	12	80	30	11,0	9,0	1	307.0024	79,67
5/8	11	80	32	12,0	9,0	1	307.0026	90,79
3/4	10	95	40	14,0	11,0	1	307.0028	120,44
7/8	9	100	40	18,0	14,5	1	307.0030	155,59
1	8	110	50	18,0	14,5	1	307.0032	177,82
1.1/4	7	132	56	22,0	18,0	1	307.0036	306,75

308

HSS Handtappenset, Unified National Fine [UNF]

Uitvoering: HSS handtappensets, DIN 2181, UNF, sets à 2 stuks.

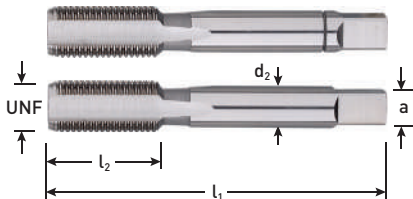

UNF	P	l_1	l_2	d_2	a	St./VE	Art.nr.	€ / VE
1/4	28	50	18	6,0	4,9	1	308.0014	21,92
5/16	24	56	22	6,0	4,9	1	308.0016	24,09
3/8	24	63	22	7,0	5,5	1	308.0018	27,18
7/16	20	63	22	8,0	6,2	1	308.0020	32,60
1/2	20	75	24	9,0	7,0	1	308.0022	40,76
9/16	18	80	28	11,0	9,0	1	308.0024	50,97
5/8	18	80	28	12,0	9,0	1	308.0026	60,52
3/4	16	95	32	14,0	11,0	1	308.0028	80,30
7/8	14	100	36	18,0	14,5	1	308.0030	103,73
1	12	110	40	18,0	14,5	1	308.0032	118,55

310

HSS Handtappenset, British Standard Pipe [BSP] (Gasdraad)

Uitvoering: HSS handtappensets, DIN 5157, gasdraad, sets à 2 stuks.

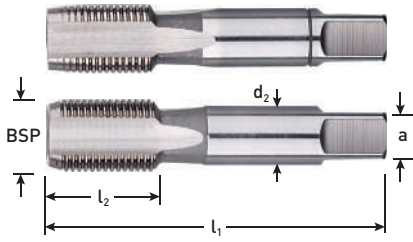

BSP	P	l_1	l_2	d_2	a	St./VE	Art.nr.	€/VE
1/8	28	63	20	7,0	5,5	1	310.0125	27,79
1/4	19	70	22	11,0	9,0	1	310.0250	30,90
3/8	19	70	22	12,0	9,0	1	310.0375	45,70
1/2	14	80	22	16,0	12,0	1	310.0500	61,76
5/8	14	80	22	18,0	14,5	1	310.0625	88,91
3/4	14	90	22	20,0	16,0	1	310.0750	92,64
7/8	14	90	22	22,0	18,0	1	310.0875	151,15
1	11	100	25	25,0	20,0	1	310.1000	157,50
1.1/8	11	125	40	28,0	22,0	1	310.1125	327,14
1.1/4	11	125	40	32,0	24,0	1	310.1250	271,75
1.1/2	11	140	40	36,0	29,0	1	310.1500	419,48
1.3/4	11	140	40	40,0	32,0	1	310.1750	711,29
2	11	160	40	45,0	35,0	1	310.2000	795,23

314

HSS Handtappenset, National Pipe Taper [NPT]

Uitvoering: HSS handtappensets, National Pipe taper (NPT), sets à 2 stuks.

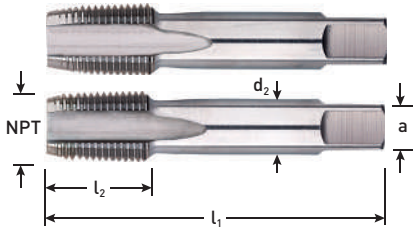

NPT	P	l_1	l_2	d_2	a	St./VE	Art.nr.	€/VE
1/16	27	52	14	5,6	4,5	1	314.0010	58,43
1/8	27	59	15	8	6,3	1	314.0012	71,52
1/4	18	67	19	10	8	1	314.0014	85,68
3/8	18	75	21	12,5	10	1	314.0016	93,67
1/2	14	87	26	16	12,5	1	314.0018	116,99
3/4	14	96	28	20	16	1	314.0022	233,73
1	11,5	109	33	25	20	1	314.0026	356,22

315

HSS Handtappenset, Panzerrohrgewinde [PG]

Uitvoering: HSS handtappensets, DIN 40432, PG-draad, sets à 2 stuks.

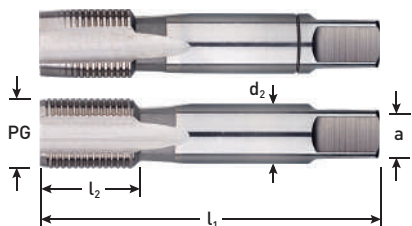

PG	P	l ₁	l ₂	d ₂	a	St./VE	Art.nr.	€ / VE
7	20	70	22	9,0	7,0	1	315.0700	51,56
9	18	70	22	12,0	9,0	1	315.0900	68,75
11	18	80	22	14,0	11,0	1	315.1100	112,63
13,5	18	80	22	16,0	12,0	1	315.1350	138,97
16	18	80	22	18,0	14,5	1	315.1600	166,77
21	16	90	22	22,0	18,0	1	315.2100	219,32
29	16	100	25	28,0	22,0	1	315.2900	364,53
36	16	140	40	36,0	29,0	1	315.3600	580,88

317

HSS Tap-bit, metrisch [M]

Uitvoering: HSS tapbit met 1/4" (6,3mm) bitopname volgens DIN 3126-C6.3.

Toepassing: Voor het snijden van metrische draad in staal, non-ferro's en kunststof met accu-schroef-boormachines.

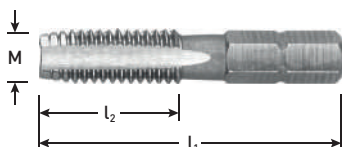

M	p	l ₁	l ₂	St./VE	Art.nr.	€ / VE
3	0,5	33	11	1	317.0300	7,08
4	0,7	35	12	1	317.0400	7,08
5	0,8	36	15	1	317.0500	8,73

M	p	l ₁	l ₂	St./VE	Art.nr.	€ / VE
6	1,0	39	18	1	317.0600	8,73
8	1,25	40	19	1	317.0800	12,75
10	1,5	41	21	1	317.1000	14,87

900

HSS Tapbitset, metrisch [M], in ABS-cassette

Uitvoering: HSS tapbitset met 1/4" (6,3mm) bitopname volgens DIN 3126-C6.3.

Toepassing: Voor het snijden van metrische draad in staal, non-ferro's en kunststof met accu-schroef-boormachines.



Omschrijving	Type	Inhoud	St./VE	Art.nr.	€ / VE
6-dlg. tap-bits-set	317	1x M3, M4, M5, M6, M8 en M10	1	900.2032	63,37

900

HSS Boor- en tapbitset, metrisch [M], in cassette

ROTEC®



Uitvoering: HSS boor- en tapbitset met 1/4" (6,3mm) bitopname volgens DIN 3126-C6.3.
Toepassing: Voor het snijden van metrische draad in staal, non-ferro's en kunststof met accu-schroef-boormachines.

Omschrijving	Type	Inhoud	St./VE	Art.nr.	€ / VE
12-dlg. Boor- en tap-bit-set	140	1x ø2,5, 3,3, 4,2, 5,0, 6,8 en 8,5	1	900.2035	112,52
	317	1x M3, M4, M5, M6, M8 en M10			

900

HSS-G OPTI-LINE Machinetappenset, doorlopend, in ABS-cassette

ROTEC®



OPTI-LINE

Toepassing: Tappen van doorlopende gaten in (gelegeerd) staal <600 N/mm². Materiaalgroepen : 1.1 - 1.2 - 1.3

Opmerking: Deze tappen zijn uitsluitend als set leverbaar!

Omschrijving	Inhoud	St./VE	Art.nr.	€ / VE
7-dlg. set machinetappen, doorlopend	HSS-G machinetap 'OPTI-LINE' (322): DIN 371 : 1x M3, M4, M5, M6, M8 en M10 DIN 376 : 1x M12	1	900.2005	79,00
7+7-dlg. set boren en machinetappen, doorlopend	HSS-G machinetap 'OPTI-LINE' (322): DIN 371 : 1x M3, M4, M5, M6, M8 en M10 DIN 376 : 1x M12 HSS-G spiraalboren: DIN 338 : 1x ø2,5 / 3,3 / 4,2 / 5,0 / 6,8 / 8,5 / 10,2 mm	1	900.2006	99,00

320

HSS-E Machinetap, metrisch, doorlopend, in EV pack

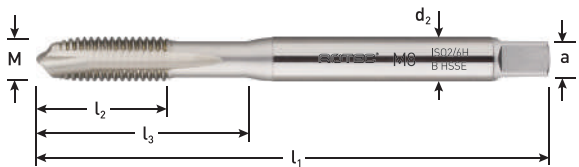

M
HSS
Co
DIN
371
DIN
376
60°

Uitvoering: HSS-E machinetappen, DIN 371, metrisch [M], 60°, verdikte schacht, type B met schilaansnijding.

Toepassing: Tappen van doorlopende gaten in (gelegeerd) staal <800 N/mm².
Materiaalgroepen : 1.1 - 1.2 - 1.3 - 1.4

Opmerking: Tappen groter dan M12 zijn verpakt in een kunststof koker QP22x75.

M	p	l ₁	l ₂	d ₂	a	l ₃	DIN	St./VE	Art.nr.	€ / VE
3	0,5	56	10	3,5	2,7	18	DIN 371	1	320.0300BE	15,95
4	0,7	63	12	4,5	3,4	21	DIN 371	1	320.0400BE	15,95
5	0,8	70	14	6,0	4,9	25	DIN 371	1	320.0500BE	16,62
6	1,0	80	18	6,0	4,9	30	DIN 371	1	320.0600BE	16,62
7	1,0	80	18	7,0	5,5	30	DIN 371	1	320.0700BE	31,13
8	1,25	90	20	8,0	6,2	35	DIN 371	1	320.0800BE	20,80
10	1,5	100	20	10,0	8,0	39	DIN 371	1	320.1000BE	26,38
3	0,5	56	10	2,2	-	-	DIN 376	1	321.0300BE	22,89
4	0,7	63	13	2,8	2,1	-	DIN 376	1	321.0400BE	17,85
5	0,8	70	16	3,5	2,7	-	DIN 376	1	321.0500BE	19,29
6	1,0	80	19	4,5	3,4	-	DIN 376	1	321.0600BE	19,29
8	1,25	90	22	6,0	4,9	-	DIN 376	1	321.0800BE	21,75
10	1,5	100	24	7,0	5,5	-	DIN 376	1	321.1000BE	28,69
12	1,75	110	29	9,0	7,0	-	DIN 376	1	321.1200BE	33,95
16	2,0	110	32	11,0	11,0	-	DIN 376	1	321.1600BE	56,21

320

HSS-E Machinetap, metrisch, blind, in EV-pack

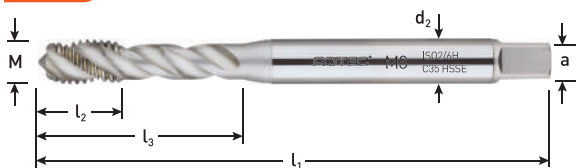

M
HSS
Co
DIN
371
DIN
376
60°

Uitvoering: HSS-E machinetappen, DIN 371, metrisch [M], 60°, verdikte schacht, type C, spiraalhoek 35°.

Toepassing: Tappen van blinde gaten in (gelegeerd) staal <800 N/mm².
Materiaalgroepen : 1.1 - 1.2 - 1.3 - 1.4

Opmerking: Tappen groter dan M12 zijn verpakt in een kunststof koker QP22x75.

M	p	l ₁	l ₂	d ₂	a	l ₃	DIN	St./VE	Art.nr.	€ / VE
3	0,5	56	5	3,5	2,7	18	DIN 371	1	320.0300CE	19,53
4	0,7	63	7	4,5	3,4	21	DIN 371	1	320.0400CE	19,53
5	0,8	70	8	6,0	4,9	25	DIN 371	1	320.0500CE	19,87
6	1,0	80	10	6,0	4,9	30	DIN 371	1	320.0600CE	19,87
8	1,25	90	13	8,0	6,2	35	DIN 371	1	320.0800CE	24,27
10	1,5	100	15	10,0	8,0	39	DIN 371	1	320.1000CE	31,55
6	1,0	80	10	4,5	3,4	-	DIN 376	1	321.0600CE	20,44
8	1,25	90	13	6,0	4,9	-	DIN 376	1	321.0800CE	24,25
10	1,5	100	15	7,0	5,5	-	DIN 376	1	321.1000CE	31,11
12	1,75	110	18	9,0	7,0	-	DIN 376	1	321.1200CE	36,63
16	2,0	110	20	12,0	9,0	-	DIN 376	1	321.1600CE	53,57

320

HSS-E Machinetap, metrisch, DIN 371, doorlopend



Uitvoering: HSS-E machinetappen, DIN 371, metrisch [M], 60°, verdikte schacht, type B met schilaansnijding.

Toepassing: Tappen van doorlopende gaten in (gelegeerd) staal <800 N/mm². Materiaalgroepen : 1.1 - 1.2 - 1.3 - 1.4

M	p	l ₁	l ₂	d ₂	a	l ₃	St./VE	Art.nr.	€/VE
3	0,5	56	10	3,5	2,7	18	1	320.0300B	15,51
4	0,7	63	12	4,5	3,4	21	1	320.0400B	15,51
5	0,8	70	14	6,0	4,9	25	1	320.0500B	16,18
6	1,0	80	18	6,0	4,9	30	1	320.0600B	16,18

M	p	l ₁	l ₂	d ₂	a	l ₃	St./VE	Art.nr.	€/VE
7	1,0	80	18	7,0	5,5	30	1	320.0700B	30,64
8	1,25	90	20	8,0	6,2	35	1	320.0800B	20,31
10	1,5	100	20	10,0	8,0	39	1	320.1000B	25,69

HSS-E Machinetap, metrisch, DIN 376, doorlopend



Uitvoering: HSS-E machinetappen, DIN 376, metrisch [M], 60°, dunne schacht, type B met schilaansnijding (t/m M16) of lange aansnijding (>M16).

Toepassing: Tappen van doorlopende gaten in (gelegeerd) staal <800 N/mm². Materiaalgroepen : 1.1 - 1.2 - 1.3 - 1.4

M	p	l ₁	l ₂	d ₂	a	l ₃	St./VE	Art.nr.	€/VE
3	0,5	56	10	2,2	-	-	1	321.0300B	22,45
4	0,7	63	13	2,8	2,1	-	1	321.0400B	17,41
5	0,8	70	16	3,5	2,7	-	1	321.0500B	18,85
6	1,0	80	19	4,5	3,4	-	1	321.0600B	18,85
8	1,25	90	22	6,0	4,9	-	1	321.0800B	21,26
10	1,5	100	24	7,0	5,5	-	1	321.1000B	28,00
12	1,75	110	29	9,0	7,0	-	1	321.1200B	33,26

M	p	l ₁	l ₂	d ₂	a	l ₃	St./VE	Art.nr.	€/VE
14	2,0	110	30	11,0	9,0	-	1	321.1400B	49,13
16	2,0	110	32	12,0	9,0	-	1	321.1600B	55,57
18	2,5	125	34	14,0	11,0	-	1	321.1800B	63,95
20	2,5	140	34	16,0	12,0	-	1	321.2000B	73,38
22	2,5	140	34	18,0	14,5	-	1	321.2200B	91,47
24	3,0	160	38	18,0	14,5	-	1	321.2400B	104,02

900

HSS-E Machinetappenset, doorlopend, in ABS-cassette



Toepassing: Tappen van doorlopende gaten in (gelegeerd) staal <800 N/mm². Materiaalgroepen : 1.1 - 1.2 - 1.3 - 1.4

Omschrijving	Inhoud	St./VE	Art.nr.	€/VE
7-dlg. set machinetappen, doorlopend	HSS-E machinetap 'OPTI' (320): DIN 371 : 1x M3, M4, M5, M6, M8 en M10 DIN 376 : 1x M12	1	900.2007	119,20
7+7-dlg. set boren en machinetappen, doorlopend	HSS-E machine tap (320): DIN 371 : 1x M3, M4, M5, M6, M8 en M10 DIN 376 : 1x M12 HSS-G spiraalboren (105): DIN 338 : 1x ø2,5 / 3,3 / 4,2 / 5,0 / 6,8 / 8,5 / 10,2 mm	1	900.2008	130,24

320

HSS-E Machinetap, metrisch, DIN 371, blind

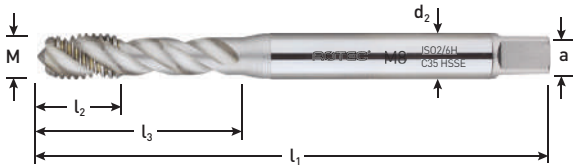

Uitvoering: HSS-E machinetappen, DIN 371, metrisch [M], 60°, verdikte schacht, type C, spiraalhoek 35°.

Toepassing: Tappen van blinde gaten in (gelegeerd) staal <800 N/mm². Materiaalgroepen : 1.1 - 1.2 - 1.3 - 1.4

M	p	l ₁	l ₂	d ₂	a	l ₃	St./VE	Art.nr.	€ / VE
3	0,5	56	5	3,5	2,7	18	1	320.0300C	19,09
4	0,7	63	7	4,5	3,4	21	1	320.0400C	19,09
5	0,8	70	8	6,0	4,9	25	1	320.0500C	19,43

M	p	l ₁	l ₂	d ₂	a	l ₃	St./VE	Art.nr.	€ / VE
6	1,0	80	10	6,0	4,9	30	1	320.0600C	19,43
8	1,25	90	13	8,0	6,2	35	1	320.0800C	23,78
10	1,5	100	15	10,0	8,0	39	1	320.1000C	30,86

HSS-E Machinetap, metrisch, DIN 376, blind



Uitvoering: HSS-E machinetappen, DIN 376, metrisch [M], 60°, dunne schacht, type C, spiraalhoek 35°.

Toepassing: Tappen van blinde gaten in (gelegeerd) staal <800 N/mm². Materiaalgroepen : 1.1 - 1.2 - 1.3 - 1.4

M	p	l ₁	l ₂	d ₂	a	l ₃	St./VE	Art.nr.	€ / VE
6	1,0	80	10	4,5	3,4	-	1	321.0600C	20,00
8	1,25	90	13	6,0	4,9	-	1	321.0800C	23,76
10	1,5	100	15	7,0	5,5	-	1	321.1000C	30,42
12	1,75	110	18	9,0	7,0	-	1	321.1200C	35,94
14	2,0	110	20	11,0	9,0	-	1	321.1400C	52,93

M	p	l ₁	l ₂	d ₂	a	l ₃	St./VE	Art.nr.	€ / VE
16	2,0	110	20	12,0	9,0	-	1	321.1600C	57,77
18	2,5	125	25	14,0	11,0	-	1	321.1800C	66,19
20	2,5	140	25	16,0	12,0	-	1	321.2000C	72,77
22	2,5	140	25	18,0	14,5	-	1	321.2200C	118,52
24	3,0	160	30	18,0	14,5	-	1	321.2400C	123,55

900

HSS-E Machinetappenset, blind, in ABS-cassette



Toepassing: Tappen van blinde gaten in (gelegeerd) staal <800 N/mm². Materiaalgroepen : 1.1 - 1.2 - 1.3 - 1.4

Omschrijving	Inhoud	St./VE	Art.nr.	€ / VE
7-dlg. set machinetappen, blind	HSS-E machinetap 'OPTI' (320): DIN 371 : 1x M3, M4, M5, M6, M8 en M10 DIN 376 : 1x M12	1	900.2007C	126,41
7+7-dlg. set boren en machinetappen, blind	HSS-E machine tap (320): DIN 371 : 1x M3, M4, M5, M6, M8 en M10 DIN 376 : 1x M12 HSS-G spiraalboren (105): DIN 338 : 1x ø2,5 / 3,3 / 4,2 / 5,0 / 6,8 / 8,5 / 10,2 mm	1	900.2008C	142,63

330

HSS-E 800 Machinetap, metrisch, DIN 371, doorlopend

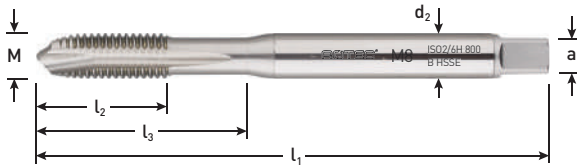

800

Uitvoering: HSS-E machinetappen, DIN 371, metrisch [M], 60°, verdikte schacht, type B met schilaansnijding.

Toepassing: Tappen van doorlopende gaten in (gelegeerd) staal <800 N/mm².
Materiaalgroepen : 1.1 - 1.2 - 1.3 - 1.4



M	p	l ₁	l ₂	d ₂	a	l ₃	St./VE	Art.nr.	€/VE
2	0,4	45	8	2,8	2,1	13	1	330.0200	37,14
2,5	0,45	50	9	2,8	2,1	14	1	330.0250	37,14
3	0,5	56	10	3,5	2,7	18	1	330.0300	21,38
3,5	0,6	56	12	4,0	3,0	20	1	330.0350	22,04
4	0,7	63	12	4,5	3,4	21	1	330.0400	21,71

M	p	l ₁	l ₂	d ₂	a	l ₃	St./VE	Art.nr.	€/VE
5	0,8	70	14	6,0	4,9	25	1	330.0500	22,84
6	1,0	80	18	6,0	4,9	30	1	330.0600	22,84
8	1,25	90	20	8,0	6,2	35	1	330.0800	26,53
10	1,5	100	20	10,0	8,0	39	1	330.1000	33,95

HSS-E 800 Machinetap, metrisch, DIN 376, doorlopend



800

Uitvoering: HSS-E machinetappen, DIN 376, metrisch [M], 60°, dunne schacht, type B met schilaansnijding (l/m M16) of lange aansnijding (>M16).

Toepassing: Tappen van doorlopende gaten in (gelegeerd) staal <800 N/mm².
Materiaalgroepen : 1.1 - 1.2 - 1.3 - 1.4



M	p	l ₁	l ₂	d ₂	a	l ₃	St./VE	Art.nr.	€/VE
12	1,75	110	29	9,0	7,0	-	1	330.1200	48,25
14	2,0	110	30	11,0	9,0	-	1	330.1400	65,96
16	2,0	110	32	12,0	9,0	-	1	330.1600	70,58
18	2,5	125	34	14,0	11,0	-	1	330.1800	96,80
20	2,5	140	34	16,0	12,0	-	1	330.2000	102,50
22	2,5	140	34	18,0	14,5	-	1	330.2200	146,21
24	3,0	160	38	18,0	14,5	-	1	330.2400	135,45
27	3,0	160	38	20,0	16,0	-	1	330.2700	181,09

M	p	l ₁	l ₂	d ₂	a	l ₃	St./VE	Art.nr.	€/VE
30	3,5	180	45	22,0	18,0	-	1	330.3000	229,16
33	3,5	180	50	25,0	20,0	-	1	330.3300	312,56
36	4,0	200	56	28,0	22,0	-	1	330.3600	424,97
39	4,0	200	60	32,0	24,0	-	1	330.3900	535,42
42	4,5	200	60	32,0	24,0	-	1	330.4200	532,81
45	4,5	220	65	36,0	29,0	-	1	330.4500	532,81
48	5,0	250	70	36,0	29,0	-	1	330.4800	567,20
52	5,0	250	70	40,0	32,0	-	1	330.5200	651,21

900

HSS-E 800 Machinetappenset, doorlopend, in ABS-cassette



Toepassing: Tappen van doorlopende gaten in (gelegeerd) staal <800 N/mm².
Materiaalgroepen : 1.1 - 1.2 - 1.3 - 1.4

Omschrijving	Inhoud	St./VE	Art.nr.	€/VE
7+7-dlg. set boren en machinetappen, doorlopend	HSS-E machine tap '800' (330): DIN 371 : 1x M3, M4, M5, M6, M8 en M10 DIN 376 : 1x M12 HSS-E spiraalboren (110): DIN 338 : 1x ø2,5 / 3,3 / 4,2 / 5,0 / 6,8 / 8,5 / 10,2 mm	1	900.2009	239,59

330

HSS-E 800 Machinetap, metrisch, DIN 371, blind

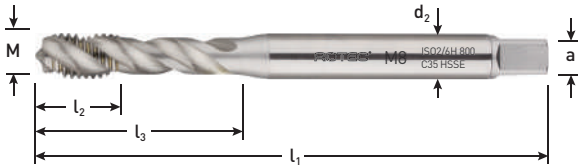

M	p	l ₁	l ₂	d ₂	a	l ₃	St./VE	Art.nr.	€ / VE
2	0,4	45	6	2,8	2,1	13	1	330.0200C	43,88
3	0,5	56	5	3,5	2,7	18	1	330.0300C	23,52
4	0,7	63	7	4,5	3,4	21	1	330.0400C	23,84
5	0,8	70	8	6,0	4,9	25	1	330.0500C	25,28

800

Uitvoering: HSS-E machinetappen, DIN 371, metrisch [M], 60°, verdikte schacht, type C, spiraalhoek 35°.

Toepassing: Tappen van blinde gaten in (gelegeerd) staal <800 N/mm².
Materiaalgroepen : 1.1 - 1.2 - 1.3 - 1.4

M	p	l ₁	l ₂	d ₂	a	l ₃	St./VE	Art.nr.	€ / VE
6	1,0	80	10	6,0	4,9	30	1	330.0600C	25,28
8	1,25	90	13	8,0	6,2	35	1	330.0800C	29,26
10	1,5	100	15	10,0	8,0	39	1	330.1000C	37,57

HSS-E 800 Machinetap, metrisch, DIN 376, blind



M	p	l ₁	l ₂	d ₂	a	l ₃	St./VE	Art.nr.	€ / VE
12	1,75	110	18	9,0	7,0	-	1	330.1200C	53,11
14	2,0	110	20	11,0	9,0	-	1	330.1400C	72,45
16	2,0	110	20	12,0	9,0	-	1	330.1600C	77,73
18	2,5	125	25	14,0	11,0	-	1	330.1800C	106,63
20	2,5	140	25	16,0	12,0	-	1	330.2000C	112,83
22	2,5	140	25	18,0	14,5	-	1	330.2200C	160,87

800

Uitvoering: HSS-E machinetappen, DIN 376, metrisch [M], 60°, dunne schacht, type C, spiraalhoek 35°.

Toepassing: Tappen van blinde gaten in (gelegeerd) staal <800 N/mm².
Materiaalgroepen : 1.1 - 1.2 - 1.3 - 1.4

M	p	l ₁	l ₂	d ₂	a	l ₃	St./VE	Art.nr.	€ / VE
24	3,0	160	30	18,0	14,5	-	1	330.2400C	148,96
27	3,0	160	30	20,0	16,0	-	1	330.2700C	199,45
30	3,5	180	45	22,0	18,0	-	1	330.3000C	233,84
33	3,5	180	50	25,0	20,0	-	1	330.3300C	343,83
36	4,0	200	40	28,0	22,0	-	1	330.3600C	467,65

900

HSS-E 800 Machinetappenset, blind, in ABS-cassette



Toepassing: Tappen van blinde gaten in (gelegeerd) staal <800 N/mm².
Materiaalgroepen : 1.1 - 1.2 - 1.3 - 1.4

Omschrijving	Inhoud	St./VE	Art.nr.	€ / VE
7+7-dlg. set boren en machinetappen, blind	HSS-E machine tap '800' (330): DIN 371 : 1x M3, M4, M5, M6, M8 en M10 DIN 376 : 1x M12 HSS-E spiraalboren (110): DIN 338 : 1x ø2,5 / 3,3 / 4,2 / 5,0 / 6,8 / 8,5 / 10,2 mm	1	900.2009C	256,82

800+

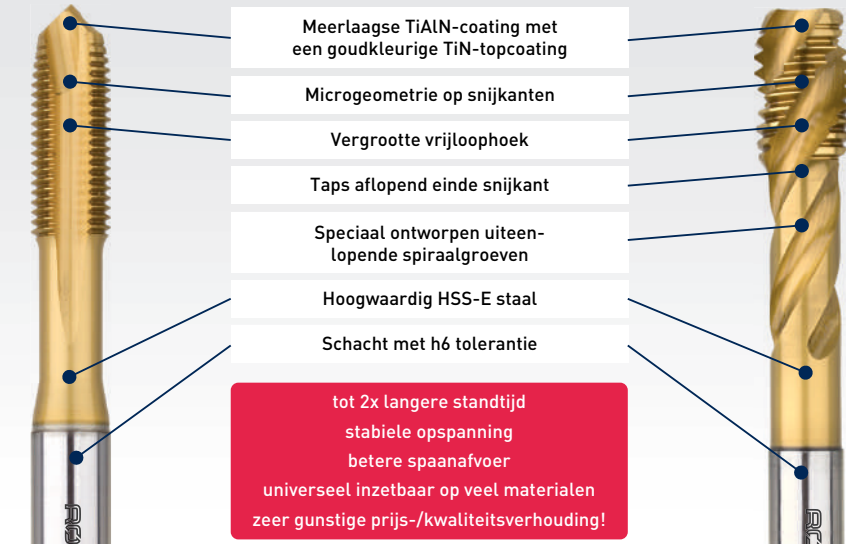

- Meerlaagse TiAlN-coating met een goudkleurige TiN-topcoating
- Microgeometrie op snijkanten
- Vergrootte vrijloophoek
- Taps aflopend einde snijkant
- Speciaal ontworpen uiteenlopende spiraalgroeven
- Hoogwaardig HSS-E staal
- Schacht met h6 tolerantie

tot 2x langere standtijd
 stabiele opspanning
 betere spaanafvoer
 universeel inzetbaar op veel materialen
 zeer gunstige prijs-/kwaliteitsverhouding!

330T

HSS-E '800+' Machinetap, metrisch, DIN 371, doorlopend

ROTEC®

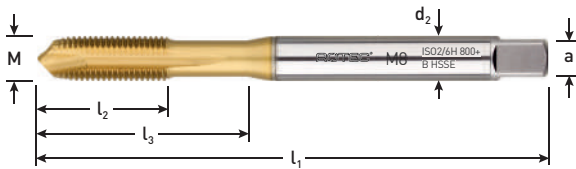

M	p	l ₁	l ₂	d ₂	a	l ₃	St./VE	Art.nr.	€/VE
3	0,5	56	10	3,5	2,7	18	1	330.0300T	24,36
3,5	0,6	56	12	4,0	3,0	20	1	330.0350T	28,73
4	0,7	63	12	4,5	3,4	21	1	330.0400T	24,62
4,5	0,75	70	14	6,0	4,9	25	1	330.0450T	41,72
5	0,8	70	14	6,0	4,9	25	1	330.0500T	26,88

800+

Uitvoering: HSS-E machinetappen, DIN 371, metrisch [M], 60°, ISO2 (6H), verdikte schacht, type B met schilaansnijding. De TN2-coating (TiAlN + TiN) zorgt voor hogere snijsnelheden en langere standtijden.

Toepassing: Universele tappen voor doorlopende gaten in (gelegeerd) staal <1.000 N/mm², roestvast staal <1.000 N/mm², gietijzer <210 HB, kortspanig aluminium en koper(legeringen).
 Materiaalgroepen : 1.1 - 1.4, 2.1 - 2.2, 3.1 - 3.2, 4.2 - 4.5

M	p	l ₁	l ₂	d ₂	a	l ₃	St./VE	Art.nr.	€/VE
6	1	80	18	6,0	4,9	30	1	330.0600T	27,89
7	1	80	18	7,0	5,5	30	1	330.0700T	38,54
8	1,25	90	20	8,0	6,2	35	1	330.0800T	33,38
9	1,25	90	20	9,0	7,0	35	1	330.0900T	55,30
10	1,5	100	20	10,0	8,0	39	1	330.1000T	43,90

HSS-E '800+' Machinetap, metrisch, DIN 376, doorlopend

ROTEC®



M	p	l ₁	l ₂	d ₂	a	l ₃	St./VE	Art.nr.	€/VE
3	0,5	56	11	2,2	1,8	-	1	330.0301T	30,20
4	0,7	63	12	2,8	2,1	-	1	330.0401T	28,99
5	0,8	70	14	3,5	2,7	-	1	330.0501T	31,46
6	1	80	18	4,5	3,4	-	1	330.0601T	32,46
8	1,25	90	20	6,0	4,9	-	1	330.0801T	38,80
10	1,5	100	20	7,0	5,5	-	1	330.1001T	49,13
12	1,75	110	24	9,0	7,0	-	1	330.1200T	60,92
14	2	110	25	11,0	9,0	-	1	330.1400T	80,39
16	2	110	32	12,0	9,0	-	1	330.1600T	87,09
18	2,5	125	32	14,0	11,0	-	1	330.1800T	118,20
20	2,5	140	32	16,0	12,0	-	1	330.2000T	129,47

800+

Uitvoering: HSS-E machinetappen, DIN 376, metrisch [M], 60°, ISO2 (6H), dunne schacht, type B met schilaansnijding. De TN2-coating (TiAlN + TiN) zorgt voor hogere snijsnelheden en langere standtijden.

Toepassing: Universele tappen voor doorlopende gaten in (gelegeerd) staal <1.000 N/mm², roestvast staal <1.000 N/mm², gietijzer <210 HB, kortspanig aluminium en koper(legeringen).
 Materiaalgroepen : 1.1 - 1.4, 2.1 - 2.2, 3.1 - 3.2, 4.2 - 4.5

M	p	l ₁	l ₂	d ₂	a	l ₃	St./VE	Art.nr.	€/VE
22	2,5	140	32	18,0	14,5	-	1	330.2200T	174,42
24	3	160	38	18,0	14,5	-	1	330.2400T	178,46
27	3	160	38	20,0	16,0	-	1	330.2700T	238,64
30	3,5	180	40	22,0	18,0	-	1	330.3000T	280,43
33	3,5	180	45	25,0	20,0	-	1	330.3300T	401,60
36	4	200	50	28,0	22,0	-	1	330.3600T	540,39
39	4	200	55	32,0	24,0	-	1	330.3900T	611,64
42	4,5	200	60	32,0	24,0	-	1	330.4200T	617,14
45	4,5	220	60	36,0	29,0	-	1	330.4500T	679,92
48	5	250	65	36,0	29,0	-	1	330.4800T	724,08
52	5	250	65	40,0	30,0	-	1	330.5200T	820,22

HSS-E '800+' Machinetap, metrisch, DIN 371, blind

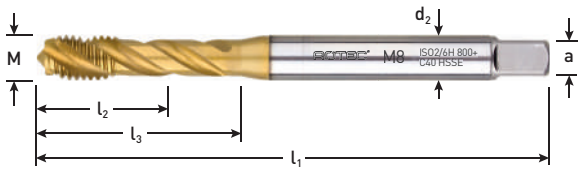

800+

Uitvoering: HSS-E machinetappen, DIN 371, metrisch [M], 60°, ISO2 (6H), verdikte schacht, type C met spiraalhoek 40°. De TN2-coating (TiAlN + TiN) zorgt voor hogere snijnsnelheden en langere standtijden.

Toepassing: Universele tappen voor blinde gaten in (gelegeerd) staal <1.000 N/mm², roestvast staal <1.000 N/mm², gietijzer <210 HB, kortspanig aluminium en koper(legeringen).
Materiaalgroepen : 1.1 - 1.4, 2.1 - 2.2, 3.1 - 3.2, 4.2 - 4.5

M	p	l ₁	l ₂	d ₂	a	l ₃	St./VE	Art.nr.	€ / VE
3	0,5	56	5	3,5	2,7	18	1	330.0300TC	25,49
3,5	0,6	56	6	4,0	3,0	20	1	330.0350TC	32,46
4	0,7	63	7	4,5	3,4	21	1	330.0400TC	25,69
4,5	0,75	70	7,5	6,0	4,9	25	1	330.0450TC	45,30
5	0,8	70	8	6,0	4,9	25	1	330.0500TC	28,01

M	p	l ₁	l ₂	d ₂	a	l ₃	St./VE	Art.nr.	€ / VE
6	1	80	10	6,0	4,9	30	1	330.0600TC	28,99
7	1	80	10	7,0	5,5	30	1	330.0700TC	41,85
8	1,25	90	13	8,0	6,2	35	1	330.0800TC	34,84
9	1,25	90	13	9,0	7,0	35	1	330.0900TC	57,08
10	1,5	100	15	10,0	8,0	39	1	330.1000TC	45,82

HSS-E '800+' Machinetap, metrisch, DIN 376, blind



800+

Uitvoering: HSS-E machinetappen, DIN 376, metrisch [M], 60°, ISO2 (6H), dunne schacht, type C met spiraalhoek 40°. De TN2-coating (TiAlN + TiN) zorgt voor hogere snijnsnelheden en langere standtijden.

Toepassing: Universele tappen voor blinde gaten in (gelegeerd) staal <1.000 N/mm², roestvast staal <1.000 N/mm², gietijzer <210 HB, kortspanig aluminium en koper(legeringen).
Materiaalgroepen : 1.1 - 1.4, 2.1 - 2.2, 3.1 - 3.2, 4.2 - 4.5

M	p	l ₁	l ₂	d ₂	a	l ₃	St./VE	Art.nr.	€ / VE
3	0,5	56	5	2,2	1,8	-	1	330.0301TC	30,27
4	0,7	63	8	2,8	2,1	-	1	330.0401TC	31,51
5	0,8	70	10	3,5	2,7	-	1	330.0501TC	34,11
6	1	80	12	4,5	3,4	-	1	330.0601TC	35,10
8	1,25	90	15	6,0	4,9	-	1	330.0801TC	41,98
10	1,5	100	17	7,0	5,5	-	1	330.1001TC	52,97
12	1,75	110	18	9,0	7,0	-	1	330.1200TC	65,55
14	2	110	20	11,0	9,0	-	1	330.1400TC	86,61
16	2	110	20	12,0	9,0	-	1	330.1600TC	93,89
18	2,5	125	25	14,0	11,0	-	1	330.1800TC	127,53
20	2,5	140	25	16,0	12,0	-	1	330.2000TC	139,32

M	p	l ₁	l ₂	d ₂	a	l ₃	St./VE	Art.nr.	€ / VE
22	2,5	140	25	18,0	14,5	-	1	330.2200TC	188,32
24	3	160	30	18,0	14,5	-	1	330.2400TC	191,49
27	3	160	30	20,0	16,0	-	1	330.2700TC	244,67
30	3,5	180	35	22,0	18,0	-	1	330.3000TC	287,46
33	3,5	180	35	25,0	20,0	-	1	330.3300TC	412,40
36	4	200	40	28,0	22,0	-	1	330.3600TC	555,36
39	4	200	40	32,0	24,0	-	1	330.3900TC	663,16
42	4,5	200	45	32,0	24,0	-	1	330.4200TC	668,46
45	4,5	220	45	36,0	29,0	-	1	330.4500TC	706,67
48	5	250	50	36,0	29,0	-	1	330.4800TC	711,63
52	5	250	50	40,0	30,0	-	1	330.5200TC	852,34

900

HSS-E '800+' Machinetappenset, in kunststof koffer



Uitvoering: HSS-E machinetappensets, DIN 371/376, metrisch [M], 60°, ISO2 (6H). De TN2-coating (TiAlN + TiN) zorgt voor hogere snijnsnelheden en langere standtijden.

Toepassing: Universele tappen voor in (gelegeerd) staal <1.000 N/mm², roestvast staal <1.000 N/mm², gietijzer <210 HB, kortspanig aluminium en koper(legeringen).
Materiaalgroepen : 1.1 - 1.4, 2.1 - 2.2, 3.1 - 3.2, 4.2 - 4.5

Omschrijving	Inhoud	St./VE	Art.nr.	€ / VE
7-dlg. set machinetappen, doorlopend	HSS-E machine tap "800+" (330T): DIN 371 : 1x M3, M4, M5, M6, M8 en M10 DIN 376 : 1x M12	1	900.2013	190,66
7-dlg. set machinetappen, blind	HSS-E machine tap "800+" (330T): DIN 371 : 1x M3, M4, M5, M6, M8 en M10 DIN 376 : 1x M12	1	900.2013C	204,97

331

HSS-E INOX 1000 Machinetap, metrisch, DIN 371, doorlopend

ROTEC®



INOX 1000

Uitvoering: High-performance HSS-E blauwring machinetap DIN 371, metrisch [M], 60°, ISO2 (6H), verdikte schacht, type B met schilaansnijding.

Toepassing: Tappen van doorlopende gaten in roestvaststaal. De INOX tappen zijn ook geschikt voor het tappen in staal <1.000 N/mm².
Materiaalgroepen : 1.1 - 1.2 - 1.3 - 1.4 - 2.1 - 2.2 - 2.3



M	p	l ₁	l ₂	d ₂	a	l ₃	St./VE	Art.nr.	€ / VE
3	0,5	56	10	3,5	2,7	18	1	331.0300	23,55
4	0,7	63	12	4,5	3,4	21	1	331.0400	23,84
5	0,8	70	14	6,0	4,9	25	1	331.0500	25,28

M	p	l ₁	l ₂	d ₂	a	l ₃	St./VE	Art.nr.	€ / VE
6	1	80	18	6,0	4,9	30	1	331.0600	25,28
8	1,25	90	20	8,0	6,2	35	1	331.0800	29,26
10	1,5	100	20	10,0	8,0	39	1	331.1000	37,57

HSS-E INOX 1000 Machinetap, metrisch, DIN 376, doorlopend

ROTEC®



INOX 1000

Uitvoering: High-performance HSS-E blauwring machinetap DIN 376, metrisch [M], 60°, ISO2 (6H), dunne schacht, type B met schilaansnijding.

Toepassing: Tappen van doorlopende gaten in roestvaststaal. De INOX tappen zijn ook geschikt voor het tappen in staal <1.000 N/mm².
Materiaalgroepen : 1.1 - 1.2 - 1.3 - 1.4 - 2.1 - 2.2 - 2.3



M	p	l ₁	l ₂	d ₂	a	l ₃	St./VE	Art.nr.	€ / VE
8	1,25	90	20	6,0	4,9	-	1	331.0801	32,27
10	1,5	100	20	7,0	5,5	-	1	331.1001	39,67
12	1,75	110	24	9,0	7,0	-	1	331.1200	53,11
16	2	110	32	12,0	9,0	-	1	331.1600	77,73

M	p	l ₁	l ₂	d ₂	a	l ₃	St./VE	Art.nr.	€ / VE
18	2,5	125	32	14,0	11,0	-	1	331.1800	106,63
20	2,5	140	32	16,0	12,0	-	1	331.2000	112,83
24	3	160	38	18,0	14,5	-	1	331.2400	148,96

900

HSS-E INOX 1000 Machinetappenset, doorlopend, in ABS-cassette

ROTEC®



Toepassing: Tappen van doorlopende gaten in roestvaststaal. De INOX tappen zijn ook geschikt voor het tappen in staal <1.000 N/mm².
Materiaalgroepen : 1.1 - 1.2 - 1.3 - 1.4 - 2.1 - 2.2 - 2.3

Omschrijving	Inhoud	St./VE	Art.nr.	€ / VE
7+7-dlg. set boren en machinetappen, doorlopend	HSS-E machine tap 'INOX 1000' (331.xxxx): DIN 371 : 1x M3, M4, M5, M6, M8 en M10 DIN 376 : 1x M12 HSS-E spiraalboren, type HD-S (110): DIN 338 : 1x ø2,5 / 3,3 / 4,2 / 5,0 / 6,8 / 8,5 / 10,2 mm	1	900.20091	260,47

331

HSS-E INOX 1000 Machinetap, metrisch, DIN 371, blind

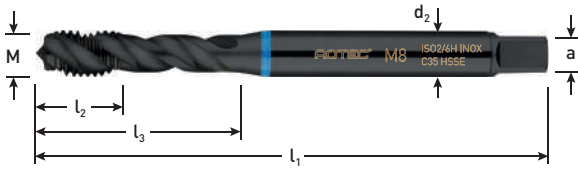

INOX 1000

Uitvoering: High-performance HSS-E blauwring machinetap DIN 371, metrisch [M], 60°, ISO2 (6H), verdikte schacht, type C met spiraalhoek 40°.

Toepassing: Tappen van blinde gaten in roestvaststaal. De INOX tappen zijn ook geschikt voor het tappen in staal <1.000 N/mm². Materiaalgroepen : 1.1 - 1.2 - 1.3 - 1.4 - 2.1 - 2.2 - 2.3

M	p	l ₁	l ₂	d ₂	a	l ₃	St./VE	Art.nr.	€/VE
3	0,5	56	5	3,5	2,7	18	1	331.0300C	25,86
4	0,7	63	7	4,5	3,4	21	1	331.0400C	26,16
5	0,8	70	8	6,0	4,9	25	1	331.0500C	27,67

M	p	l ₁	l ₂	d ₂	a	l ₃	St./VE	Art.nr.	€/VE
6	1	80	10	6,0	4,9	30	1	331.0600C	27,67
8	1,25	90	13	8,0	6,2	35	1	331.0800C	32,22
10	1,5	100	15	10,0	8,0	39	1	331.1000C	41,32

HSS-E INOX 1000 Machinetap, metrisch, DIN 376, blind

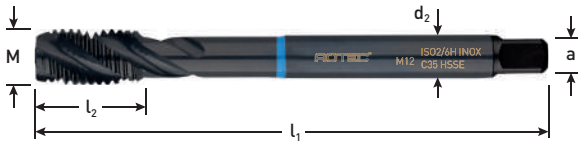

INOX 1000

Uitvoering: High-performance HSS-E blauwring machinetap DIN 376, metrisch [M], 60°, ISO2 (6H), dunne schacht, type C met spiraalhoek 40°.

Toepassing: Tappen van blinde gaten in roestvaststaal. De INOX tappen zijn ook geschikt voor het tappen in staal <1.000 N/mm². Materiaalgroepen : 1.1 - 1.2 - 1.3 - 1.4 - 2.1 - 2.2 - 2.3

M	p	l ₁	l ₂	d ₂	a	l ₃	St./VE	Art.nr.	€/VE
12	1,75	110	18	9,0	7,0	-	1	331.1200C	58,37
16	2	110	20	12,0	9,0	-	1	331.1600C	85,30
18	2,5	125	25	14,0	11,0	-	1	331.1800C	117,23

M	p	l ₁	l ₂	d ₂	a	l ₃	St./VE	Art.nr.	€/VE
20	2,5	140	25	16,0	12,0	-	1	331.2000C	124,18
24	3	160	30	18,0	14,5	-	1	331.2400C	163,98

900

HSS-E INOX 1000 Machinetappenset, blind, in ABS-cassette



Toepassing: Tappen van blinde gaten in roestvaststaal. De INOX tappen zijn ook geschikt voor het tappen in staal <1.000 N/mm². Materiaalgroepen : 1.1 - 1.2 - 1.3 - 1.4 - 2.1 - 2.2 - 2.3

Omschrijving	Inhoud	St./VE	Art.nr.	€/VE
7+7-dlg. set boren en machinetappen, blind	HSS-E machine tap 'INOX 1000' [331.xxxxC]: DIN 371 : 1x M3, M4, M5, M6, M8 en M10 DIN 376 : 1x M12 HSS-E spiraalboren, type HD-S (110): DIN 338 : 1x ø2,5 / 3,3 / 4,2 / 5,0 / 6,8 / 8,5 / 10,2 mm	1	900.20091C	278,33

Inox+



- Slijtvaste HardLube®-coating met een zeer gladde oppervlakte
 - Speciale geometriën voor RVS / INOX
 - Nauwkeurige en goed afgewerkte draad
 - Taps aflopende snijkant
 - Divergerende spiraalgroeven voor verbeterde spaanafvoer
 - Hoogwaardig HSS-E staal
 - Schacht met h6 tolerantie
- Speciale geometriën voor ferritisch, martensitisch en austenitisch roestvaststaal en duplex.**
- Dé probleemoplosser voor RVS!**

331H

HSS-E 'Inox+' Machinetap, metrisch, DIN 371, doorlopend



M	p	l ₁	l ₂	d ₂	a	l ₃	St./VE	Art.nr.	€ / VE
3	0,5	56	10	3,5	2,7	18	1	331.0300H	25,23
4	0,7	63	12	4,5	3,4	21	1	331.0400H	26,80
5	0,8	70	14	6,0	4,9	25	1	331.0500H	29,75

Inox+

Uitvoering: HSS-E machinetappen, DIN 371, metrisch [M], 60°, ISO2 (6H), verdikte schacht, type B met schilaansnijding. De dunne maar slijtvaste HardLube®-coating met een lage wrijvingscoëfficiënt zorgt voor hogere snijnsnelheden en langere standtijden.

Toepassing: Specifiek ontwikkeld voor het tappen van doorlopende gaten in austenitische roestvast- en zuurbestendige staalsoorten en duplex <1.000 N/mm².
Materiaalgroepen : 2.1 - 2.3

M	p	l ₁	l ₂	d ₂	a	l ₃	St./VE	Art.nr.	€ / VE
6	1	80	18	6,0	4,9	30	1	331.0600H	31,46
8	1,25	90	20	8,0	6,2	35	1	331.0800H	38,28
10	1,5	100	20	10,0	8,0	39	1	331.1000H	51,18

HSS-E 'Inox+' Machinetap, metrisch, DIN 376, doorlopend



M	p	l ₁	l ₂	d ₂	a	l ₃	St./VE	Art.nr.	€ / VE
8	1,25	90	20	6,0	4,9	-	1	331.0801H	41,93
10	1,5	100	20	7,0	5,5	-	1	331.1001H	54,42
12	1,75	110	24	9,0	7,0	-	1	331.1200H	70,19
14	2	110	25	11,0	9,0	-	1	331.1400H	94,10
16	2	110	32	12,0	9,0	-	1	331.1600H	99,29
18	2,5	125	32	14,0	11,0	-	1	331.1800H	138,78
20	2,5	140	32	16,0	12,0	-	1	331.2000H	142,83

Inox+

Uitvoering: HSS-E machinetappen, DIN 376, metrisch [M], 60°, ISO2 (6H), dunne schacht, type B met schilaansnijding. De dunne maar slijtvaste HardLube®-coating met een lage wrijvingscoëfficiënt zorgt voor hogere snijnsnelheden en langere standtijden.

Toepassing: Specifiek ontwikkeld voor het tappen van doorlopende gaten in austenitische roestvast- en zuurbestendige staalsoorten en duplex <1.000 N/mm².
Materiaalgroepen : 2.1 - 2.3

M	p	l ₁	l ₂	d ₂	a	l ₃	St./VE	Art.nr.	€ / VE
22	2,5	140	32	18,0	14,5	-	1	331.2200H	184,75
24	3	160	38	18,0	14,5	-	1	331.2400H	218,06
27	3	160	38	20,0	16,0	-	1	331.2700H	245,00
30	3,5	180	40	22,0	18,0	-	1	331.3000H	318,51
33	3,5	180	45	25,0	20,0	-	1	331.3300H	424,57
36	4	200	50	28,0	22,0	-	1	331.3600H	569,23

HSS-E 'Inox+' Machinetap, metrisch, DIN 371, blind

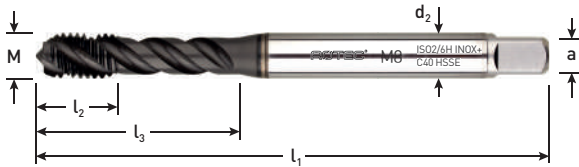

Inox+

Uitvoering: HSS-E machinetappen, DIN 371, metrisch [M], 60°, ISO2 (6H), verdikte schacht, type C met spiraalhoek 40°. De dunne maar slijtvaste HardLube®-coating met een lage wrijvingscoëfficiënt zorgt voor hogere snijnelheden en langere standtijden.

Toepassing: Specifiek ontwikkeld voor het tappen van blinde gaten in austenitische roestvast- en zuurbestendige staalsoorten en duplex <1.000 N/mm².
Materiaalgroepen : 2.1 - 2.3

M	p	l ₁	l ₂	d ₂	a	l ₃	St./VE	Art.nr.	€/VE
3	0,5	56	5	3,5	2,7	18	1	331.0300HC	29,60
4	0,7	63	7	4,5	3,4	21	1	331.0400HC	28,71
5	0,8	70	8	6,0	4,9	25	1	331.0500HC	31,77

M	p	l ₁	l ₂	d ₂	a	l ₃	St./VE	Art.nr.	€/VE
6	1	80	10	6,0	4,9	30	1	331.0600HC	33,51
8	1,25	90	13	8,0	6,2	35	1	331.0800HC	45,84
10	1,5	100	15	10,0	8,0	39	1	331.1000HC	54,37

HSS-E 'Inox+' Machinetap, metrisch, DIN 376, blind



Inox+

Uitvoering: HSS-E machinetappen, DIN 376, metrisch [M], 60°, ISO2 (6H), dunne schacht, type C met spiraalhoek 40°. De dunne maar slijtvaste HardLube®-coating met een lage wrijvingscoëfficiënt zorgt voor hogere snijnelheden en langere standtijden.

Toepassing: Specifiek ontwikkeld voor het tappen van blinde gaten in austenitische roestvast- en zuurbestendige staalsoorten en duplex <1.000 N/mm².
Materiaalgroepen : 2.1 - 2.3

M	p	l ₁	l ₂	d ₂	a	l ₃	St./VE	Art.nr.	€/VE
8	1,25	90	15	6,0	4,9	-	1	331.0801HC	43,72
10	1,5	100	17	7,0	5,5	-	1	331.1001HC	52,38
12	1,75	110	18	9,0	7,0	-	1	331.1200HC	74,47
14	2	110	20	11,0	9,0	-	1	331.1400HC	105,63
16	2	110	20	12,0	9,0	-	1	331.1600HC	105,78
18	2,5	125	25	14,0	11,0	-	1	331.1800HC	141,57
20	2,5	140	25	16,0	12,0	-	1	331.2000HC	164,68

M	p	l ₁	l ₂	d ₂	a	l ₃	St./VE	Art.nr.	€/VE
22	2,5	140	25	18,0	14,5	-	1	331.2200HC	198,79
24	3	160	30	18,0	14,5	-	1	331.2400HC	231,11
27	3	160	30	20,0	16,0	-	1	331.2700HC	262,42
30	3,5	180	35	22,0	18,0	-	1	331.3000HC	299,55
33	3,5	180	35	25,0	20,0	-	1	331.3300HC	456,17
36	4	200	40	28,0	22,0	-	1	331.3600HC	570,07

900

HSS-E 'Inox+' Machinetapset, in kunststof koffer



Uitvoering: HSS-E machinetapset, DIN 371/376, metrisch [M], 60°, ISO2 (6H). De dunne maar slijtvaste HardLube®-coating met een lage wrijvingscoëfficiënt zorgt voor hogere snijnelheden en langere standtijden.

Toepassing: Specifiek ontwikkeld voor het tappen in austenitische roestvast- en zuurbestendige staalsoorten en duplex <1.000 N/mm².
Materiaalgroepen : 2.1 - 2.3

Omschrijving	Inhoud	St./VE	Art.nr.	€/VE
7-dlg. set machinetappen, doorlopend	HSS-E machine tap 'Inox+' (331H): DIN 371 : 1x M3, M4, M5, M6, M8 en M10 DIN 376 : 1x M12	1	900.2014	239,32
7-dlg. set machinetappen, blind	HSS-E machine tap 'Inox+' (331H): DIN 371 : 1x M3, M4, M5, M6, M8 en M10 DIN 376 : 1x M12	1	900.2014C	257,69

1200+

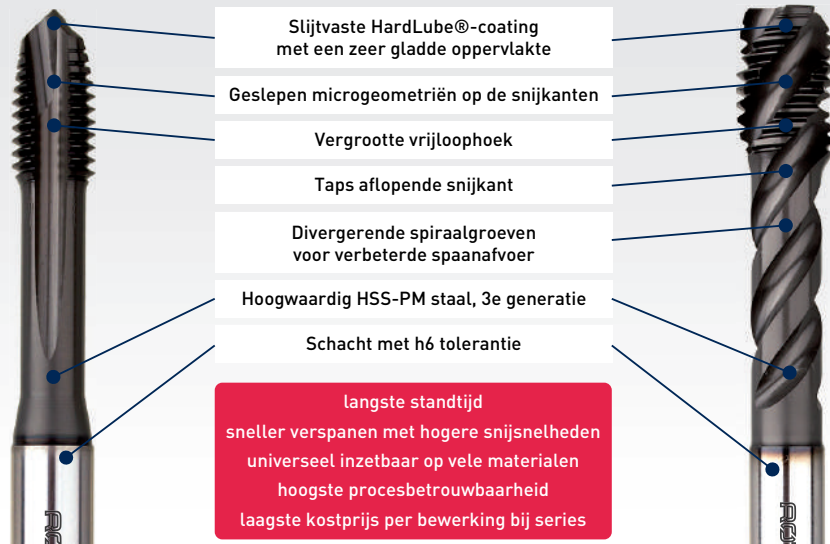
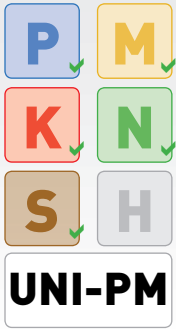

- Slijtvaste HardLube®-coating met een zeer gladde oppervlakte
 - Geslepen microgeometriën op de snijkanten
 - Vergrootte vrijloophoek
 - Taps aflopende snijkant
 - Divergerende spiraalgroeven voor verbeterde spaanafvoer
 - Hoogwaardig HSS-PM staal, 3e generatie
 - Schacht met h6 tolerantie
- langste standtijd
sneller verspanen met hogere snij snelheden
universeel inzetbaar op vele materialen
hoogste procesbetrouwbaarheid
laagste kostprijs per bewerking bij series

336

HSS-E PM '1200+' Machinetap, metrisch, DIN 371, doorlopend

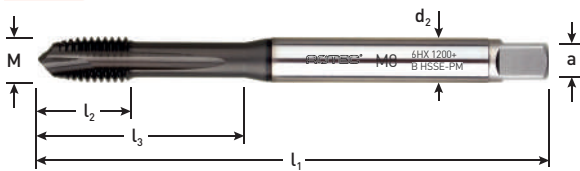

M	p	l ₁	l ₂	d ₂	a	l ₃	St./VE	Art.nr.	€/VE
2	0,4	45	10	2,8	2,1	13	1	336.0200	42,20
2,5	0,45	50	9	2,8	2,1	14	1	336.0250	42,20
3	0,5	56	5	3,5	2,7	18	1	336.0300	32,70
4	0,7	63	7	4,5	3,4	21	1	336.0400	34,43

1200+

Uitvoering: HSS-E PM machinetappen, DIN 371, metrisch [M], 60°, ISO1(4H) (M1-M1,4), ISO2(6H) (M1,6-M2,6), 6HX (M3-M10), verdikte schacht, type B met schilaansnijding. De dunne maar slijtvaste HardLube®-coating met een lage wrijvingscoëfficiënt zorgt hogere snij snelheden en langere standtijden.

Toepassing: Universele high-performance tappen voor doorlopende gaten in (gelegeerd) staal <1.200 N/mm², roestvast staal <1.000 N/mm², gietijzer <240 HB, aluminium(legeringen), koper(legeringen), superlegeringen en titanium <675 N/mm².
Materiaalgroepen : 1.1 - 1.5, 2.1 - 2.3, 3.1 - 3.3, 4.1 - 4.10, 5.1, 5.3

M	p	l ₁	l ₂	d ₂	a	l ₃	St./VE	Art.nr.	€/VE
5	0,8	70	8	6,0	4,9	25	1	336.0500	37,38
6	1	80	10	6,0	4,9	30	1	336.0600	38,71
8	1,25	90	13	8,0	6,2	35	1	336.0800	46,53
10	1,5	100	15	10,0	8,0	39	1	336.1000	61,16

HSS-E PM '1200+' Machinetap, metrisch, DIN 376, doorlopend



M	p	l ₁	l ₂	d ₂	a	l ₃	St./VE	Art.nr.	€/VE
12	1,75	110	18	9,0	7,0	-	1	336.1200	90,11
14	2	110	20	11,0	9,0	-	1	336.1400	118,17
16	2	110	20	12,0	9,0	-	1	336.1600	127,02

1200+

Uitvoering: HSS-E PM machinetappen, DIN 376, metrisch [M], 60°, 6HX, dunne schacht, type B met schilaansnijding. De dunne maar slijtvaste HardLube®-coating met een lage wrijvingscoëfficiënt zorgt hogere snij snelheden en langere standtijden.

Toepassing: Universele high-performance tappen voor doorlopende gaten in (gelegeerd) staal <1.200 N/mm², roestvast staal <1.000 N/mm², gietijzer <240 HB, aluminium(legeringen), koper(legeringen), superlegeringen en titanium <675 N/mm².
Materiaalgroepen : 1.1 - 1.5, 2.1 - 2.3, 3.1 - 3.3, 4.1 - 4.10, 5.1, 5.3

M	p	l ₁	l ₂	d ₂	a	l ₃	St./VE	Art.nr.	€/VE
20	2,5	140	25	16,0	12,0	-	1	336.2000	188,54
24	3	160	30	18,0	14,5	-	1	336.2400	243,37

HSS-E PM '1200+' Machinetap, metrisch, DIN 371, blind

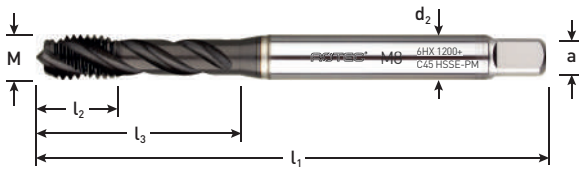

1200+

Uitvoering: HSS-E PM machinetappen, DIN 371, metrisch [M], 60°, ISO1(4H) [M1-M1,4], ISO2(6H) [M1,6-M2,6], 6HX (M3-M10), verdikte schacht, type C met spiraalhoek 45°. De dunne maar slijtvaste HardLube®-coating met een lage wrijvingscoëfficiënt zorgt hogere snijnsnelheden en langere standtijden.

Toepassing: Universele high-performance tappen voor blinde gaten in (gelegeerd) staal <1.200 N/mm², roestvast staal <1.000 N/mm², gietijzer <240 HB, aluminium(legeringen), koper(legeringen), superlegeringen en titanium <675 N/mm².
Materiaalgroepen : 1.1 - 1.5, 2.1 - 2.3, 3.1 - 3.3, 4.1 - 4.10, 5.1, 5.3

M	p	l ₁	l ₂	d ₂	a	l ₃	St./VE	Art.nr.	€/VE
2	0,4	45	10	2,8	2,1	13	1	336.0200C	46,96
2,5	0,45	50	9	2,8	2,1	14	1	336.0250C	46,96
3	0,5	56	5	3,5	2,7	18	1	336.0300C	36,30
4	0,7	63	7	4,5	3,4	21	1	336.0400C	38,28

M	p	l ₁	l ₂	d ₂	a	l ₃	St./VE	Art.nr.	€/VE
5	0,8	70	8	6,0	4,9	25	1	336.0500C	41,54
6	1	80	10	6,0	4,9	30	1	336.0600C	43,05
8	1,25	90	13	8,0	6,2	35	1	336.0800C	51,71
10	1,5	100	15	10,0	8,0	39	1	336.1000C	67,90

HSS-E PM '1200+' Machinetap, metrisch, DIN 376, blind



1200+

Uitvoering: HSS-E PM machinetappen, DIN 376, metrisch [M], 60°, 6HX, dunne schacht, type C met spiraalhoek 45°. De dunne maar slijtvaste HardLube®-coating met een lage wrijvingscoëfficiënt zorgt hogere snijnsnelheden en langere standtijden.

Toepassing: Universele high-performance tappen voor blinde gaten in (gelegeerd) staal <1.200 N/mm², roestvast staal <1.000 N/mm², gietijzer <240 HB, aluminium(legeringen), koper(legeringen), superlegeringen en titanium <675 N/mm².
Materiaalgroepen : 1.1 - 1.5, 2.1 - 2.3, 3.1 - 3.3, 4.1 - 4.10, 5.1, 5.3

M	p	l ₁	l ₂	d ₂	a	l ₃	St./VE	Art.nr.	€/VE
12	1,75	110	18	9,0	7,0	-	1	336.1200C	100,17
14	2	110	20	11,0	9,0	-	1	336.1400C	131,29

M	p	l ₁	l ₂	d ₂	a	l ₃	St./VE	Art.nr.	€/VE
16	2	110	20	12,0	9,0	-	1	336.1600C	141,16
20	2,5	140	25	16,0	12,0	-	1	336.2000C	209,49

900

HSS-E PM '1200+' Machinetappenset, in kunststof koffer



Uitvoering: HSS-E PM machinetap DIN 371/376, metrisch [M], 60°, 6HX. De dunne maar slijtvaste HardLube®-coating met een lage wrijvingscoëfficiënt zorgt hogere snijnsnelheden en langere standtijden.

Toepassing: Universele high-performance tappen voor in (gelegeerd) staal <1.200 N/mm², roestvast staal <1.000 N/mm², gietijzer <240 HB, aluminium(legeringen), koper(legeringen), superlegeringen en titanium <675 N/mm².
Materiaalgroepen : 1.1 - 1.5, 2.1 - 2.3, 3.1 - 3.3, 4.1 - 4.10, 5.1, 5.3

Omschrijving	Inhoud	St./VE	Art.nr.	€/VE
7-dlg. set machinetappen, doorlopend	HSS-E PM machine tap '1200+' [336]: DIN 371 : 1x M3, M4, M5, M6, M8 en M10 DIN 376 : 1x M12	1	900.2011	307,23
7-dlg. set machinetappen, blind	HSS-E PM machine tap '1200+' [336]: DIN 371 : 1x M3, M4, M5, M6, M8 en M10 DIN 376 : 1x M12	1	900.2011C	349,97

347

HSS-E-PM 1400 Machinetap, metrisch, DIN 371, doorlopend

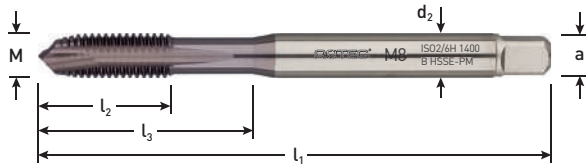

M	p	l ₁	l ₂	d ₂	a	l ₃	St./VE	Art.nr.	€ / VE
3	0,5	56	10	3,5	2,7	18	1	347.0300	28,51
4	0,7	63	12	4,5	3,4	21	1	347.0400	28,88
5	0,8	70	14	6,0	4,9	25	1	347.0500	31,21

1400

Uitvoering: High-performance HSS-E-PM (poedermetallurgische) roodring machinetappen, DIN 371, metrisch [M], 60°, ISO2 (6H), verdikte schacht, type B met schilaansnijding, TiCN-coating voor langere standtijden en hogere snijcondities. PM tappen hebben een zeer hoge taaiheid bij een zeer hoge slijtvastheid.

Toepassing: Tappen van doorlopende gaten in (hoog) gelegeerd staal <1.400 N/mm², Hardox 400/500, Weldox etc.
Materiaalgroep: 1.1 t/m 1.6 - 3.2 - 3.3

M	p	l ₁	l ₂	d ₂	a	l ₃	St./VE	Art.nr.	€ / VE
6	1	80	18	6,0	4,9	30	1	347.0600	32,32
8	1,25	90	20	8,0	6,2	35	1	347.0800	38,92
10	1,5	100	20	10,0	8,0	39	1	347.1000	51,09

HSS-E-PM 1400 Machinetap, metrisch, DIN 376, doorlopend



M	p	l ₁	l ₂	d ₂	a	l ₃	St./VE	Art.nr.	€ / VE
12	1,75	110	24	9,0	7,0	-	1	347.1200	76,42
16	2	110	32	12,0	9,0	-	1	347.1600	109,45

1400

Uitvoering: High-performance HSS-E-PM (poedermetallurgische) roodring machinetappen, DIN 376, metrisch [M], 60°, ISO2 (6H), dunne schacht, type B met schilaansnijding, TiCN-coating voor langere standtijden en hogere snijcondities. PM tappen hebben een zeer hoge taaiheid bij een zeer hoge slijtvastheid.

Toepassing: Tappen van doorlopende gaten in (hoog) gelegeerd staal <1.400 N/mm², Hardox 400/500, Weldox etc.
Materiaalgroep: 1.1 t/m 1.6 - 3.2 - 3.3

M	p	l ₁	l ₂	d ₂	a	l ₃	St./VE	Art.nr.	€ / VE
20	2,5	140	32	16,0	12,0	-	1	347.2000	170,37
24	3	160	38	18,0	14,5	-	1	347.2400	315,15

HSS-E-PM 1400 Machinetap, metrisch, DIN 371, blind

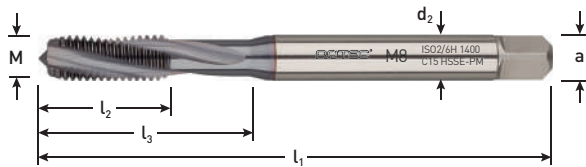

M	p	l ₁	l ₂	d ₂	a	l ₃	St./VE	Art.nr.	€ / VE
3	0,5	56	5	3,5	2,7	18	1	347.0300C	35,31
4	0,7	63	7	4,5	3,4	21	1	347.0400C	35,72
5	0,8	70	8	6,0	4,9	25	1	347.0500C	38,43

1400

Uitvoering: High-performance HSS-E-PM (poedermetallurgische) roodring machinetappen, DIN 371, metrisch [M], 60°, ISO2 (6H), verdikte schacht, type C met spiraalhoek 15°, TiCN-coating voor langere standtijden en hogere snijcondities. PM tappen hebben een zeer hoge taaiheid bij een zeer hoge slijtvastheid.

Toepassing: Tappen van blinde gaten in (hoog) gelegeerd staal <1.400 N/mm², Hardox 400/500, Weldox etc.
Materiaalgroep: 1.1 t/m 1.6 - 3.2 - 3.3

M	p	l ₁	l ₂	d ₂	a	l ₃	St./VE	Art.nr.	€ / VE
6	1	80	10	6,0	4,9	30	1	347.0600C	39,60
8	1,25	90	13	8,0	6,2	35	1	347.0800C	47,27
10	1,5	100	15	10,0	8,0	39	1	347.1000C	61,95

HSS-E-PM 1400 Machinetap, metrisch, DIN 376, blind



M	p	l ₁	l ₂	d ₂	a	l ₃	St./VE	Art.nr.	€ / VE
12	1,75	110	18	9,0	7,0	-	1	347.1200C	93,25
16	2	110	20	12,0	9,0	-	1	347.1600C	134,22

1400

Uitvoering: High-performance HSS-E-PM (poedermetallurgische) roodring machinetappen, DIN 376, metrisch [M], 60°, ISO2 (6H), dunne schacht, type C met spiraalhoek 15°, TiCN-coating voor langere standtijden en hogere snijcondities. PM tappen hebben een zeer hoge taaiheid bij een zeer hoge slijtvastheid.

Toepassing: Tappen van blinde gaten in (hoog) gelegeerd staal <1.400 N/mm², Hardox 400/500, Weldox etc.
Materiaalgroep: 1.1 t/m 1.6 - 3.2 - 3.3

M	p	l ₁	l ₂	d ₂	a	l ₃	St./VE	Art.nr.	€ / VE
20	2,5	140	25	16,0	12,0	-	1	347.2000C	208,03
24	3	160	30	18,0	14,5	-	1	347.2400C	283,90

333 HSS-E UNI Machinetap, metrisch, DIN 371, doorlopend

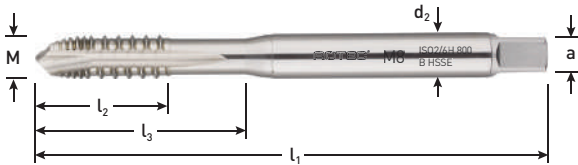

UNI

Uitvoering: HSS-E machinetappen met onderbroken draad, volgens DIN 371 (t/m M10) met verdikte schacht en DIN 376 (M12) met dunne schacht, metrisch [M], 60°.

Toepassing: Tappen van doorlopende gaten in ongelegeerd staal (<800 N/mm²), aluminium, messing en brons.
Materiaalgroepen : 1.1 t/m 1.3 - 4.1 t/m 4.10

M	p	l ₁	l ₂	d ₂	a	l ₃	St./VE	Art.nr.	€ / VE
3	0,5	56	10	3,5	2,7	18	1	333.0300	28,61
4	0,7	63	12	4,5	3,4	21	1	333.0400	29,01
5	0,8	70	14	6,0	4,9	25	1	333.0500	30,53
6	1	80	18	6,0	4,9	30	1	333.0600	30,53

M	p	l ₁	l ₂	d ₂	a	l ₃	St./VE	Art.nr.	€ / VE
8	1,25	90	20	8,0	6,2	35	1	333.0800	35,65
10	1,5	100	20	10,0	8,0	39	1	333.1000	45,61
12	1,75	110	29	9,0	7,0	-	1	333.1200	64,66

330 HSS-E 800 Machinetap, metrisch links, DIN 371, doorlopend

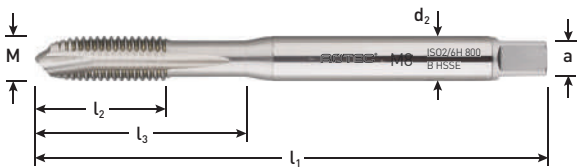

800

Uitvoering: HSS-E machinetappen, DIN 371, metrisch links [M], 60°, ISO2 (6H), verdikte schacht, type B met schilaansnijding.

Toepassing: Tappen van doorlopende gaten in (gelegeerd) staal <800 N/mm².
Materiaalgroepen : 1.1 - 1.2 - 1.3 - 1.4

M	p	l ₁	l ₂	d ₂	a	l ₃	St./VE	Art.nr.	€ / VE
3	0,5	56	10	3,5	2,7	18	1	330.0300L	40,09
4	0,7	63	12	4,5	3,4	21	1	330.0400L	40,09
5	0,8	70	14	6,0	4,9	25	1	330.0500L	41,69

M	p	l ₁	l ₂	d ₂	a	l ₃	St./VE	Art.nr.	€ / VE
6	1	80	18	6,0	4,9	30	1	330.0600L	41,69
8	1,25	90	20	8,0	6,2	35	1	330.0800L	50,90
10	1,5	100	20	10,0	8,0	39	1	330.1000L	57,30

HSS-E 800 Machinetap, metrisch links, DIN 376, doorlopend



800

Uitvoering: HSS-E machinetappen, DIN 376, metrisch links [M], 60°, ISO2 (6H), dunne schacht, type B met schilaansnijding.

Toepassing: Tappen van doorlopende gaten in (gelegeerd) staal <800 N/mm².
Materiaalgroepen : 1.1 - 1.2 - 1.3 - 1.4

M	p	l ₁	l ₂	d ₂	a	l ₃	St./VE	Art.nr.	€ / VE
12	1,75	110	24	9,0	7,0	-	1	330.1200L	72,16
14	2	110	25	11,0	9,0	-	1	330.1400L	115,32
16	2	110	32	12,0	9,0	-	1	330.1600L	106,20

M	p	l ₁	l ₂	d ₂	a	l ₃	St./VE	Art.nr.	€ / VE
18	2,5	125	32	14,0	11,0	-	1	330.1800L	200,31
20	2,5	140	32	16,0	12,0	-	1	330.2000L	204,40

HSS-E-PM Rolttap, metrisch, gecoat (TiN)

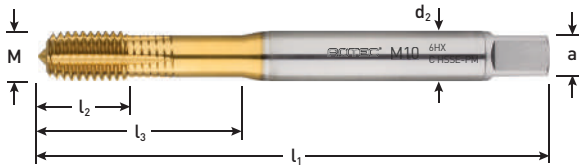

Uitvoering: High-performance HSS-E-PM (poedermetallurgische) rolltappen, DIN 371/376, metrisch [M], 60°, ISO2 (6HX), smeergroeven, TiN-coating voor langere standtijden en hogere snijcondities. PM rolltappen hebben een zeer hoge taaheid bij een zeer hoge slijtvastheid.

Toepassing: Voor het (synchro)rolltappen van blinde en doorlopende gaten tot 3xD in een zeer groot bereik aan materiaalsoorten met een rekgrens >10%. Zeer universeel toepasbaar. Materiaalgroepen : 1.1 t/m 1.4 - 2.1 t/m 2.3 - 4.1 t/m 4.5 - 5.1

M **HSS-E** **DIN**
PM **371/376** **60°** **TiN**

M	p	l ₁	l ₂	d ₂	a	l ₃	St./VE	Art.nr.	€ / VE
2	0,4	45	8	2,8	2,1	8	1	353.0200	63,97
2,5	0,45	50	9	2,8	2,1	9	1	353.0250	63,97
3	0,5	56	10	3,5	2,7	18	1	353.0300	41,25
4	0,7	63	7	4,5	3,4	21	1	353.0400	41,25
5	0,8	70	8	6,0	4,9	25	1	353.0500	45,50

M	p	l ₁	l ₂	d ₂	a	l ₃	St./VE	Art.nr.	€ / VE
6	1	80	10	6,0	4,9	30	1	353.0600	47,72
8	1,25	90	13	8,0	6,2	35	1	353.0800	58,26
10	1,5	100	15	10,0	8,0	39	1	353.1000	71,19
12	1,75	110	18	9,0	7,0	-	1	353.1200	89,33
16	2	110	20	12,0	9,0	-	1	353.1600	134,62

HSS-E-PM Rolttap, metrisch, gecoat (TiCN)

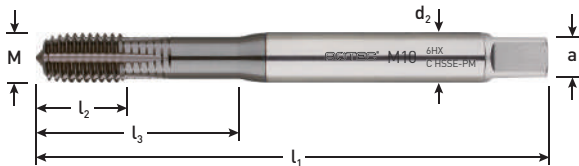

Uitvoering: High-performance HSS-E-PM (poedermetallurgische) rolltappen, DIN 371, metrisch [M], 60°, ISO2 (6HX), smeergroeven, TiCN-coating voor langere standtijden en hogere snijcondities. PM rolltappen hebben een zeer hoge taaheid bij een zeer hoge slijtvastheid.

Toepassing: Voor het (synchro)rolltappen van blinde en doorlopende gaten tot 3xD in een zeer groot bereik aan materiaalsoorten met een rekgrens >10%. Zeer universeel toepasbaar. Materiaalgroepen : 1.1 t/m 1.4 - 2.1 t/m 2.3 - 4.1 t/m 4.5 - 5.1

M **HSS-E** **DIN**
PM **371** **60°** **TiCN**

M	p	l ₁	l ₂	d ₂	a	l ₃	St./VE	Art.nr.	€ / VE
3	0,5	56	10	3,5	2,7	18	1	353.0300T	43,75
4	0,7	63	7	4,5	3,4	21	1	353.0400T	43,75
5	0,8	70	8	6,0	4,9	25	1	353.0500T	48,06

M	p	l ₁	l ₂	d ₂	a	l ₃	St./VE	Art.nr.	€ / VE
6	1	80	10	6,0	4,9	30	1	353.0600T	50,47
8	1,25	90	13	8,0	6,2	35	1	353.0800T	61,74
10	1,5	100	15	10,0	8,0	39	1	353.1000T	75,60

HSS-E-PM Rolttap, metrisch, gecoat (TiCN), koelkanalen

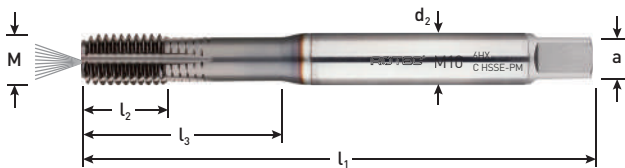

Uitvoering: High-performance HSS-E-PM (poedermetallurgische) (koelkanaal) rolltappen, DIN 371, metrisch [M], 60°, ISO2 (6HX), smeergroeven, TiCN-coating voor langere standtijden en hogere snijcondities. PM rolltappen hebben een zeer hoge taaheid bij een zeer hoge slijtvastheid.

Toepassing: Voor het (synchro)rolltappen van blinde en doorlopende gaten tot 3xD in een zeer groot bereik aan materiaalsoorten met een rekgrens >10%. Zeer universeel toepasbaar. Materiaalgroepen : 1.1 t/m 1.4 - 2.1 t/m 2.3 - 4.1 t/m 4.5 - 5.1

M **HSS-E** **DIN**
PM **371** **60°** **TiCN** **IK**

M	p	l ₁	l ₂	d ₂	a	l ₃	St./VE	Art.nr.	€ / VE
5	0,8	70	8	6,0	4,9	25	1	353.0500TK	81,96
6	1	80	10	6,0	4,9	30	1	353.0600TK	85,56

M	p	l ₁	l ₂	d ₂	a	l ₃	St./VE	Art.nr.	€ / VE
8	1,25	90	13	8,0	6,2	35	1	353.0800TK	103,81
10	1,5	100	15	10,0	8,0	39	1	353.1000TK	125,76

349

HSS-E Machinetap, metrisch, extra lang

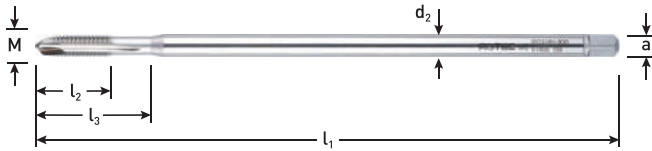

Uitvoering: HSS-E machinetappen, DIN 371-EL (t/m M6) en DIN 376-EL (M8 en groter), metrisch [M], 60°, extra lange uitvoering, type B met korte aansnijding.

Toepassing: Tappen van doorlopende gaten in [gelegeerd] staal <800 N/mm².
Materiaalgroepen : 1.1 - 1.2 - 1.3 - 1.4

M	p	l ₁	l ₂	d ₂	a	l ₃	St./VE	Art.nr.	€/VE
3	0,5	100	10	3,5	2,7	18	1	349.0300	41,13
4	0,7	125	12	4,5	3,0	21	1	349.0400	41,60
5	0,8	140	14	6,0	4,9	25	1	349.0500	43,97
6	1	160	18	6,0	4,9	30	1	349.0600	43,97
8	1,25	180	20	6,0	4,9	-	1	349.0800	50,94

M	p	l ₁	l ₂	d ₂	a	l ₃	St./VE	Art.nr.	€/VE
10	1,5	200	22	7,0	5,5	-	1	349.1000	65,79
12	1,75	220	29	9,0	7,0	-	1	349.1200	92,66
14	2	220	30	11,0	9,0	-	1	349.1400	133,23
16	2	220	32	12,0	9,0	-	1	349.1600	135,67

350

HSS Machinetap, metrisch, lang



Uitvoering: HSS machinetappen, DIN 357, metrisch [M], 60°, lange uitvoering, type B met lange aansnijding.

Toepassing: Tappen van doorlopende gaten in (gelegeerd) staal <800 N/mm².
Materiaalgroepen : 1.1 - 1.2 - 1.3 - 1.4

M	p	l ₁	l ₂	d ₂	a	St./VE	Art.nr.	€/VE
3	0,5	70	22	2,2	-	1	350.0300	26,70
4	0,7	90	25	2,8	2,1	1	350.0400	25,26
5	0,8	100	28	3,5	2,7	1	350.0500	26,70
6	1	110	32	4,5	3,4	1	350.0600	28,51

M	p	l ₁	l ₂	d ₂	a	St./VE	Art.nr.	€/VE
8	1,25	125	40	6,3	4,9	1	350.0800	31,91
10	1,5	140	45	8,0	5,5	1	350.1000	36,65
12	1,75	180	50	9,0	7,0	1	350.1200	46,16

327

HSS-E Machinetap, metrisch, kort

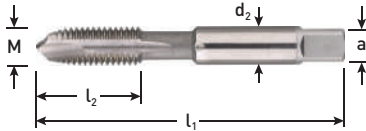

Uitvoering: HSS-E machinetappen, ISO 529, metrisch [M], 60°, korte uitvoering, type B met schilaansnijding.
Toepassing: Tappen van doorlopende gaten in (gelegeerd) staal <800 N/mm². Materiaalgroepen : 1.1 - 1.2 - 1.3 - 1.4



M	p	l ₁	l ₂	d ₂	a	St./VE	Art.nr.	€ / VE
3	0,5	48	11	3,15	2,5	1	327.0300	13,10
4	0,7	53	13	4,0	3,15	1	327.0400	13,10
5	0,8	58	16	5,0	4,0	1	327.0500	14,28
6	1	66	19	6,3	5,0	1	327.0600	14,67

M	p	l ₁	l ₂	d ₂	a	St./VE	Art.nr.	€ / VE
8	1,25	72	22	8,0	6,3	1	327.0800	18,65
10	1,5	80	24	10,0	8,0	1	327.1000	23,00
12	1,75	89	29	9,0	7,1	1	327.1200	32,54

328

HSS-E Machinetap, metrisch, extra kort

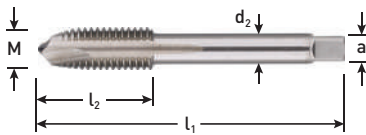

Uitvoering: HSS-E machinetappen, DIN 352, metrisch [M], 60°, extra korte uitvoering, type B met schilaansnijding.
Toepassing: Tappen van doorlopende gaten in (gelegeerd) staal <800 N/mm². Materiaalgroepen : 1.1 - 1.2 - 1.3 - 1.4



M	p	l ₁	l ₂	d ₂	a	St./VE	Art.nr.	€ / VE
3	0,5	40	11	3,5	2,7	1	328.0300	8,04
4	0,7	40	13	4,5	3,4	1	328.0400	8,04
5	0,8	48	16	6,0	4,9	1	328.0500	8,04
6	1	50	19	6,0	4,9	1	328.0600	8,58

M	p	l ₁	l ₂	d ₂	a	St./VE	Art.nr.	€ / VE
8	1,25	56	22	6,0	4,9	1	328.0800	10,79
10	1,5	70	24	7,0	5,5	1	328.1000	12,66
12	1,75	75	29	9,0	7,0	1	328.1200	16,43

Draadsnijset, metrisch [M], in kunststof koffer



Omschrijving	Inhoud	St./VE	Art.nr.	€ / VE
26-dlg. tappen-, boren- en snijplatenet	1x tap M3, M4, M5, M6, M8, M10 en M12 1x snijplaat M3, M4, M5, M6, M8, M10 en M12 1x boor ø2,5 - 3,3 - 4,2 - 5,0 - 6,8 - 8,5 - 10,2 mm 1x tapkruk nr.1 1x snijplaathouder 25x9 1x wringijzer nr.2 1x draadmeter (metrisch) 1x schroevendraaier	1	900.2026	170,84

335

HSS-E 800 Machinetap, metrisch fijn, DIN 371, doorlopend



MF	p	l ₁	l ₂	d ₂	a	l ₃	St./VE	Art.nr.	€/VE
4	0,5	63	12	4,5	3,4	21	1	335.0405	31,06
5	0,5	70	14	6,0	4,9	25	1	335.0505	45,34
6	0,75	80	14	6,0	4,9	30	1	335.0607	45,07
7	0,75	80	18	7,0	5,5	30	1	335.0707	36,82

800

Uitvoering: HSS-E machinetappen, DIN 371, metrisch-fijn [MF], 60°, ISO2 (6H), verdikte schacht, type B met schilaansnijding.

Toepassing: Tappen van doorlopende gaten in (gelegeerd) staal <800 N/mm².
Materiaalgroepen : 1.1 - 1.2 - 1.3 - 1.4

MF	p	l ₁	l ₂	d ₂	a	l ₃	St./VE	Art.nr.	€/VE
8	0,75	80	18	8,0	6,2	30	1	335.0807	46,69
8	1	90	20	8,0	6,2	35	1	335.0810	42,32
10	1	90	20	10,0	8,0	35	1	335.1010	46,41
10	1,25	100	20	10,0	8,0	39	1	335.1012	51,74

HSS-E 800 Machinetap, metrisch fijn, DIN 374, doorlopend



MF	p	l ₁	l ₂	d ₂	a	St./VE	Art.nr.	€/VE
5	0,75	70	12	3,5	2,7	1	335.0507	46,15
6	0,5	80	14	4,5	3,4	1	335.0605	46,15
9	1	90	20	8,0	6,2	1	335.0910	35,34
10	0,75	90	20	7,0	5,5	1	335.1007	48,47
12	1	100	20	9,0	7,0	1	335.1210	57,94
12	1,25	100	20	9,0	7,0	1	335.1212	65,88
12	1,5	100	20	9,0	7,0	1	335.1215	53,12
13	1	100	20	11,0	9,0	1	335.1310	68,42
13	1,5	100	20	11,0	9,0	1	335.1315	68,42
14	1	100	20	11,0	9,0	1	335.1410	72,57
14	1,25	100	20	11,0	9,0	1	335.1412	66,42
14	1,5	100	20	11,0	9,0	1	335.1415	72,57
15	1	100	20	12,0	9,0	1	335.1510	79,47
15	1,5	100	20	12,0	9,0	1	335.1515	79,47
16	1	100	20	12,0	9,0	1	335.1610	84,30
16	1,25	100	22	12,0	9,0	1	335.1612	127,47
16	1,5	100	20	12,0	9,0	1	335.1615	74,50
18	1	110	24	14,0	11,0	1	335.1810	115,49
18	1,25	110	24	14,0	11,0	1	335.1812	96,03
18	1,5	110	24	14,0	11,0	1	335.1815	88,74
18	2	125	24	14,0	11,0	1	335.1820	125,31
20	1,5	125	24	16,0	12,0	1	335.2015	103,44

800

Uitvoering: HSS-E machinetappen, DIN 374, metrisch-fijn [MF], 60°, ISO2 (6H), dunne schacht, type B met schilaansnijding.

Toepassing: Tappen van doorlopende gaten in (gelegeerd) staal <800 N/mm².
Materiaalgroepen : 1.1 - 1.2 - 1.3 - 1.4

MF	p	l ₁	l ₂	d ₂	a	St./VE	Art.nr.	€/VE
20	2	125	24	16,0	12,0	1	335.2020	152,59
22	1	125	25	18,0	14,5	1	335.2210	153,77
22	1,5	125	24	18,0	14,5	1	335.2215	147,46
22	2	125	24	18,0	14,5	1	335.2220	160,90
24	1	140	27	18,0	14,5	1	335.2410	149,00
24	1,5	140	27	18,0	14,5	1	335.2415	136,48
24	2	140	28	18,0	14,5	1	335.2420	149,00
25	1,5	140	27	18,0	14,5	1	335.2515	241,75
26	1,5	140	27	18,0	14,5	1	335.2615	286,70
27	1,5	140	27	20,0	16,0	1	335.2715	225,54
27	2	140	27	20,0	16,0	1	335.2720	294,72
30	1	150	27	22,0	18,0	1	335.3010	418,23
30	1,5	150	27	22,0	18,0	1	335.3015	214,27
30	2	150	28	22,0	18,0	1	335.3020	233,74
32	1,5	150	27	22,0	18,0	1	335.3215	233,74
33	1,5	160	30	25,0	20,0	1	335.3315	422,34
36	1,5	170	30	28,0	22,0	1	335.3615	318,12
36	2	170	30	28,0	22,0	1	335.3620	488,52
38	1,5	170	24	28,0	22,0	1	335.3815	467,46
40	1,5	170	25	32,0	24,0	1	335.4015	384,10
50	1,5	190	27	36,0	29,0	1	335.5015	934,83
63	1,5	275	40	50,0	39,0	1	335.6315	2.089,42

HSS-E 800 Machinetap, metrisch fijn, DIN 374, blind



MF	p	l ₁	l ₂	d ₂	a	St./VE	Art.nr.	€/VE
6	0,75	80	8	6,0	4,9	1	335.0607C	39,88
8	0,75	80	8	8,0	4,9	1	335.0807C	54,40
8	1	90	10	6,0	4,9	1	335.0810C	50,87
10	1	90	10	7,0	5,5	1	335.1010C	54,16
10	1,25	100	15	7,0	5,5	1	335.1012C	56,97
12	1	100	10	9,0	7,0	1	335.1210C	66,52
12	1,25	100	15	9,0	7,0	1	335.1212C	83,80

800

Uitvoering: HSS-E machinetappen, DIN 374, metrisch-fijn [MF], 60°, ISO2 (6H), dunne schacht, type C met spiraalhoek 40°.

Toepassing: Tappen van blinde gaten in (gelegeerd) staal <800 N/mm².
Materiaalgroepen : 1.1 - 1.2 - 1.3 - 1.4

MF	p	l ₁	l ₂	d ₂	a	St./VE	Art.nr.	€/VE
12	1,5	100	15	9,0	7,0	1	335.1215C	64,04
14	1,5	100	15	11,0	9,0	1	335.1415C	87,53
16	1,5	100	15	12,0	9,0	1	335.1615C	82,06
20	1,5	125	17	16,0	12,0	1	335.2015C	113,83
22	1,5	125	17	18,0	14,5	1	335.2215C	162,23
24	1,5	140	20	18,0	14,5	1	335.2415C	181,36

3351 HSS-E INOX Machinetap, metrisch fijn, DIN 371, doorlopend

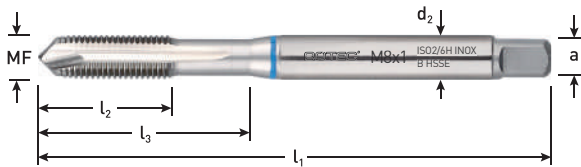

MF	p	l ₁	l ₂	d ₂	a	l ₃	St./VE	Art.nr.	€/VE
5	0,5	70	14	6,0	4,9	25	1	335.0505I	48,25
6	0,75	80	14	6,0	4,9	30	1	335.0607I	36,29
8	0,75	80	18	8,0	6,2	30	1	335.0807I	37,75

INOX 1000

Uitvoering: HSS-E machinetappen, DIN 371, metrisch-fijn [MF], 60°, ISO2 (6H), verdikte schacht, type B met schilaansnijding.

Toepassing: Tappen van doorlopende gaten in roestvaststaal. De INOX tappen zijn ook geschikt voor het tappen in staal <1.000 N/mm².
Materiaalgroepen : 1.1 - 1.2 - 1.3 - 1.4 - 2.1 - 2.2 - 2.3

MF	p	l ₁	l ₂	d ₂	a	l ₃	St./VE	Art.nr.	€/VE
8	1	90	20	8,0	6,2	35	1	335.0810I	36,62
10	1	90	20	10,0	8,0	35	1	335.1010I	43,25
10	1,25	100	20	10,0	8,0	39	1	335.1012I	48,21

HSS-E INOX Machinetap, metrisch fijn, DIN 374, doorlopend



MF	p	l ₁	l ₂	d ₂	a	l ₃	St./VE	Art.nr.	€/VE
12	1	100	20	9,0	7,0	-	1	335.1210I	58,47
12	1,25	100	20	9,0	7,0	-	1	335.1212I	66,49
12	1,5	100	20	9,0	7,0	-	1	335.1215I	58,47
14	1	100	20	11,0	9,0	-	1	335.1410I	79,94
14	1,25	100	20	11,0	9,0	-	1	335.1412I	73,11
14	1,5	100	20	11,0	9,0	-	1	335.1415I	79,94
16	1,25	100	20	12,0	9,0	-	1	335.1612I	85,43

INOX 1000

Uitvoering: HSS-E machinetappen, DIN 374, metrisch-fijn [MF], 60°, ISO2 (6H), dunne schacht, type B met schilaansnijding.

Toepassing: Tappen van doorlopende gaten in roestvaststaal. De INOX tappen zijn ook geschikt voor het tappen in staal <1.000 N/mm².
Materiaalgroepen : 1.1 - 1.2 - 1.3 - 1.4 - 2.1 - 2.2 - 2.3

MF	p	l ₁	l ₂	d ₂	a	l ₃	St./VE	Art.nr.	€/VE
16	1,5	100	20	12,0	9,0	-	1	335.1615I	82,06
18	1	110	24	14,0	11,0	-	1	335.1810I	127,13
18	1,5	110	24	14,0	11,0	-	1	335.1815I	97,73
20	1,5	125	24	16,0	12,0	-	1	335.2015I	113,83
22	1,5	125	24	18,0	14,5	-	1	335.2215I	162,23
24	1,5	140	27	18,0	14,5	-	1	335.2415I	150,31
25	1,5	140	27	18,0	14,5	-	1	335.2515I	331,61

HSS-E INOX Machinetap, metrisch fijn, DIN 374, blind

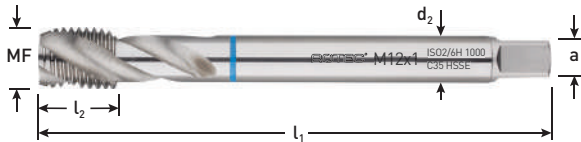

INOX 1000

Uitvoering: HSS-E machinetappen, DIN 374, metrisch-fijn [MF], 60, ISO2 (6H), dunne schacht, type C met spiraalhoek 40°.

Toepassing: Tappen van blinde gaten in roestvaststaal. De INOX tappen zijn ook geschikt voor het tappen in staal <1.000 N/mm². Materiaalgroepen : 1.1 - 1.2 - 1.3 - 1.4 - 2.1 - 2.2 - 2.3



MF	p	l ₁	l ₂	d ₂	a	l ₃	St./VE	Art.nr.	€ / VE
8	1	90	10	6,0	4,9	-	1	335.0810IC	43,92
10	1	90	10	7,0	5,5	-	1	335.1010IC	47,48
12	1,5	100	15	9,0	7,0	-	1	335.1215IC	64,23
14	1,5	100	15	11,0	9,0	-	1	335.1415IC	87,87

MF	p	l ₁	l ₂	d ₂	a	l ₃	St./VE	Art.nr.	€ / VE
16	1,5	100	15	12,0	9,0	-	1	335.1615IC	90,18
20	1,5	125	17	16,0	12,0	-	1	335.2015IC	125,28
24	1,5	140	20	18,0	14,5	-	1	335.2415IC	165,27

337

HSS-E 800 Machinetap, BSW (Whitworth), DIN 371, doorlopend

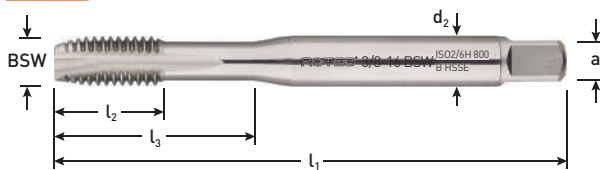

800

Uitvoering: HSS-E machinetappen, DIN 371, BSW, 55°, verdikte schacht, type B met schilaansnijding.

Toepassing: Tappen van doorlopende gaten in (gelegeerd) staal <800 N/mm². Materiaalgroepen : 1.1 - 1.2 - 1.3 - 1.4



BSW	P	l ₁	l ₂	d ₂	a	l ₃	St./VE	Art.nr.	€ / VE
1/8	40	56	10	3,5	2,7	18	1	337.0006	29,03
5/32	32	63	13	4,5	3,4	21	1	337.0008	27,87
3/16	24	70	14	6,0	4,9	25	1	337.0010	29,03
1/4	20	80	18	7,0	5,5	32	1	337.0014	29,03

BSW	P	l ₁	l ₂	d ₂	a	l ₃	St./VE	Art.nr.	€ / VE
5/16	18	90	20	8,0	6,2	35	1	337.0016	35,26
3/8	16	100	21	9,0	7,0	39	1	337.0018	41,15
7/16	14	100	22	11,0	9,0	-	1	337.0020	47,44
1/2	12	110	25	12,0	9,0	-	1	337.0022	48,88

HSS-E 800 Machinetap, BSW (Whitworth), DIN 376, doorlopend



800

Uitvoering: HSS-E machinetappen, DIN 376, BSW, 55°, dunne schacht, type B met schilaansnijding.

Toepassing: Tappen van doorlopende gaten in (gelegeerd) staal <800 N/mm². Materiaalgroepen : 1.1 - 1.2 - 1.3 - 1.4



BSW	P	l ₁	l ₂	d ₂	a	l ₃	St./VE	Art.nr.	€ / VE
9/16	12	110	26	11,0	9,0	-	1	337.0024	70,52
5/8	11	110	27	12,0	9,0	-	1	337.0026	70,52
3/4	10	125	30	14,0	11,0	-	1	337.0030	146,77

BSW	P	l ₁	l ₂	d ₂	a	l ₃	St./VE	Art.nr.	€ / VE
7/8	9	140	32	18,0	14,5	-	1	337.0034	166,43
1	8	160	36	20,0	16,0	-	1	337.0038	187,91

338

HSS-E 800 Machinetap, UNC, DIN 371, doorlopend

ROTEC®

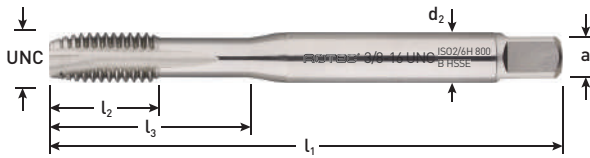

UNC	P	l ₁	l ₂	d ₂	a	l ₃	St./VE	Art.nr.	€/VE
Nr. 4	40	56	10	3,5	2,7	18	1	338.0040	27,87
Nr. 5	40	56	10	3,5	2,7	18	1	338.0050	26,19
Nr. 6	32	56	12	4,0	3,0	20	1	338.0060	27,49
Nr. 8	32	63	12	4,5	3,4	21	1	338.0080	27,49
Nr.10	24	70	14	6,0	4,9	25	1	338.0100	27,75

800

Uitvoering: HSS-E machinetappen, DIN 371, verdikte schacht, UNC, 60°, ISO2 (6H), type B met schlaansnijding.

Toepassing: Tappen van doorlopende gaten in (gelegeerd) staal <800 N/mm².
Materiaalgroepen : 1.1 - 1.2 - 1.3 - 1.4

UNC	P	l ₁	l ₂	d ₂	a	l ₃	St./VE	Art.nr.	€/VE
Nr.12	24	80	18	6,0	4,9	30	1	338.0120	27,42
1/4	20	80	18	7,0	5,5	32	1	338.0140	27,87
5/16	18	90	20	8,0	6,2	35	1	338.0160	31,72
3/8	16	100	21	10,0	8,0	39	1	338.0180	37,35

HSS-E 800 Machinetap, UNC, DIN 376, doorlopend

ROTEC®



UNC	P	l ₁	l ₂	d ₂	a	l ₃	St./VE	Art.nr.	€/VE
7/16	14	100	22	8,0	6,2	-	1	338.0200	53,12
1/2	13	110	24	9,0	7,0	-	1	338.0220	53,12
9/16	12	110	25	11,0	9,0	-	1	338.0240	76,15
5/8	11	110	32	12,0	9,0	-	1	338.0260	71,25

800

Uitvoering: HSS-E machinetappen, DIN 376, dunne schacht, UNC, 60°, ISO2 (6H), type B met schlaansnijding.

Toepassing: Tappen van doorlopende gaten in (gelegeerd) staal <800 N/mm².
Materiaalgroepen : 1.1 - 1.2 - 1.3 - 1.4

UNC	P	l ₁	l ₂	d ₂	a	l ₃	St./VE	Art.nr.	€/VE
3/4	10	125	32	14,0	11,0	-	1	338.0280	103,44
7/8	9	140	32	18,0	14,5	-	1	338.0300	154,76
1	8	160	36	18,0	14,5	-	1	338.0320	136,48
1.1/4	7	180	45	22,0	18,0	-	1	338.0360	283,47

HSS-E 800 Machinetap, UNC, DIN 371, blind

ROTEC®

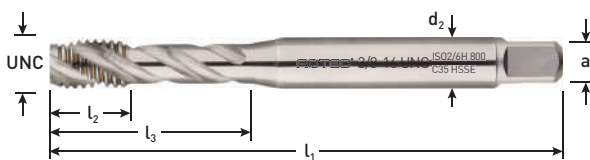

UNC	P	l ₁	l ₂	d ₂	a	l ₃	St./VE	Art.nr.	€/VE
1/4	20	80	18	7,0	5,5	13	1	338.0140C	36,74
5/16	18	90	20	8,0	6,2	13	1	338.0160C	42,66
3/8	16	100	21	10,0	8,0	15	1	338.0180C	46,90

800

Uitvoering: HSS-E machinetappen, DIN 371, verdikte schacht, UNC, 60°, ISO2 (6H), type C met spiraalhoek 40°.

Toepassing: Tappen van blinde gaten in (gelegeerd) staal <800 N/mm².
Materiaalgroepen : 1.1 - 1.2 - 1.3 - 1.4

UNC	P	l ₁	l ₂	d ₂	a	l ₃	St./VE	Art.nr.	€/VE
1/4	20	80	18	7,0	5,5	13	1	338.0140C	36,74
5/16	18	90	20	8,0	6,2	13	1	338.0160C	42,66
3/8	16	100	21	10,0	8,0	15	1	338.0180C	46,90

HSS-E 800 Machinetap, UNC, DIN 376, blind

ROTEC®



UNC	P	l ₁	l ₂	d ₂	a	l ₃	St./VE	Art.nr.	€/VE
7/16	14	100	20	8,0	6,2	-	1	338.0200C	59,24
1/2	13	110	24	9,0	7,0	-	1	338.0220C	59,68
9/16	12	110	28	11,0	9,0	-	1	338.0240C	83,77
5/8	11	110	30	12,0	9,0	-	1	338.0260C	85,32

800

Uitvoering: HSS-E machinetappen, DIN 376, dunne schacht, UNC, 60°, ISO2 (6H), type C met spiraalhoek 40°.

Toepassing: Tappen van blinde gaten in (gelegeerd) staal <800 N/mm².
Materiaalgroepen : 1.1 - 1.2 - 1.3 - 1.4

UNC	P	l ₁	l ₂	d ₂	a	l ₃	St./VE	Art.nr.	€/VE
3/4	10	125	32	14,0	11,0	-	1	338.0280C	178,17
7/8	9	140	32	18,0	14,5	-	1	338.0300C	277,66
1	8	160	36	18,0	14,5	-	1	338.0320C	340,02
1.1/4	7	180	40	22,0	18,0	-	1	338.0360C	577,22

339 HSS-E 800 Machinetap, UNF, DIN 371, doorlopend

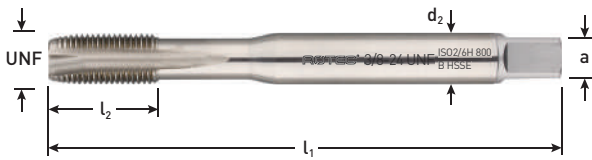

800

Uitvoering: HSS-E machinetappen, DIN 371, verdikte schacht, UNF, 60°, ISO2 (6H), type B met schilaansnijding.

Toepassing: Tappen van doorlopende gaten in (gelegeerd) staal <800 N/mm². Materiaalgroepen : 1.1 - 1.2 - 1.3 - 1.4

UNF	P	l ₁	l ₂	d ₂	a	St./VE	Art.nr.	€ / VE
Nr. 4	48	50	10	3,5	2,7	1	339.0040	28,68
Nr. 6	40	56	10	4,0	3,0	1	339.0060	28,68
Nr. 8	36	63	12	4,5	3,4	1	339.0080	28,68
Nr.10	32	70	14	6,0	4,9	1	339.0100	31,99
1/4	28	80	18	7,0	5,5	1	339.0140	35,10
5/16	24	90	20	8,0	6,2	1	339.0160	36,55
3/8	24	100	21	10,0	8,0	1	339.0180	43,25

HSS-E 800 Machinetap, UNF, DIN 376, doorlopend



800

Uitvoering: HSS-E machinetappen, DIN 376, dunne schacht, UNF, 60°, ISO2 (6H), type B met schilaansnijding.

Toepassing: Tappen van doorlopende gaten in (gelegeerd) staal <800 N/mm². Materiaalgroepen : 1.1 - 1.2 - 1.3 - 1.4

UNF	P	l ₁	l ₂	d ₂	a	St./VE	Art.nr.	€ / VE
7/16	20	100	20	8,0	6,2	1	339.0200	54,96
1/2	20	100	20	9,0	7,0	1	339.0220	61,13
9/16	18	100	20	11,0	9,0	1	339.0240	70,52
5/8	18	100	20	12,0	9,0	1	339.0260	73,48
3/4	16	110	25	14,0	11,0	1	339.0280	142,19
7/8	14	140	26	18,0	14,5	1	339.0300	168,02
1	12	150	28	20,0	16,0	1	339.0320	187,91

HSS-E 800 Machinetap, UNF, DIN 371, blind

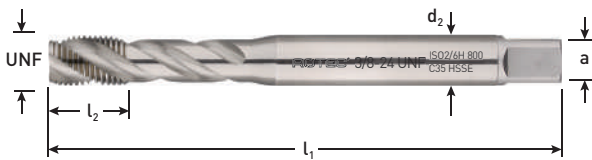

800

Uitvoering: HSS-E machinetappen, DIN 371, verdikte schacht, UNF, 60°, ISO2 (6H), type C met spiraalhoek 40°.

Toepassing: Tappen van blinde gaten in (gelegeerd) staal <800 N/mm². Materiaalgroepen : 1.1 - 1.2 - 1.3 - 1.4

UNF	P	l ₁	l ₂	d ₂	a	St./VE	Art.nr.	€ / VE
Nr.10	32	70	14	6,0	4,9	1	339.0100C	44,63
1/4	28	80	18	7,0	5,5	1	339.0140C	36,74
5/16	24	90	20	8,0	6,2	1	339.0160C	44,46
3/8	24	100	20	10,0	8,0	1	339.0180C	48,88

HSS-E 800 Machinetap, UNF, DIN 376, blind



800

Uitvoering: HSS-E machinetappen, DIN 376, dunne schacht, UNF, 60°, ISO2 (6H), type C met spiraalhoek 40°.

Toepassing: Tappen van blinde gaten in (gelegeerd) staal <800 N/mm². Materiaalgroepen : 1.1 - 1.2 - 1.3 - 1.4

UNF	P	l ₁	l ₂	d ₂	a	St./VE	Art.nr.	€ / VE
7/16	20	100	20	8,0	6,2	1	339.0200C	59,24
1/2	20	100	20	9,0	7,0	1	339.0220C	59,24
9/16	18	100	20	11,0	9,0	1	339.0240C	85,32
3/4	16	110	25	14,0	11,0	1	339.0280C	170,99
7/8	14	140	26	18,0	14,5	1	339.0300C	277,66
1	12	150	28	20,0	16,0	1	339.0320C	340,02

341

HSS-E 800 Machinetap, BSP, doorlopend



800

Uitvoering: HSS-E machinetappen, DIN 5156, BSP (G, gasdraad), 55°, ISO2 (6H), type B met schilaansnijding.

Toepassing: Tappen van doorlopende gaten in (gelegeerd) staal <800 N/mm². Materiaalgroepen : 1.1 - 1.2 - 1.3 - 1.4



BSP	P	l ₁	l ₂	d ₂	a	St./VE	Art.nr.	€ / VE
1/8	28	90	18	7,0	5,5	1	341.0125	43,77
1/4	19	100	22	11,0	9,0	1	341.0250	74,90
3/8	19	100	22	12,0	9,0	1	341.0375	77,48
1/2	14	125	25	16,0	12,0	1	341.0500	103,44
5/8	14	125	25	18,0	14,5	1	341.0625	157,78
3/4	14	140	28	20,0	16,0	1	341.0750	174,57

BSP	P	l ₁	l ₂	d ₂	a	St./VE	Art.nr.	€ / VE
7/8	14	150	28	22,0	18,0	1	341.0875	172,77
1	11	160	30	25,0	20,0	1	341.1000	257,04
1.1/4	11	170	25	32,0	24,0	1	341.1250	405,47
1.1/2	11	190	32	36,0	29,0	1	341.1500	561,57
2	11	220	40	45,0	35,0	1	341.2000	945,74

HSS-E 800 Machinetap, BSP, blind



800

Uitvoering: HSS-E machinetappen, DIN 5156, BSP (G, gasdraad), 55°, ISO2 (6H), type C met spiraalhoek 40°.

Toepassing: Tappen van blinde gaten in (gelegeerd) staal <800 N/mm². Materiaalgroepen : 1.1 - 1.2 - 1.3 - 1.4



BSP	P	l ₁	l ₂	d ₂	a	St./VE	Art.nr.	€ / VE
1/8	28	90	10	7,0	5,5	1	341.0125C	48,21
1/4	19	100	14	11,0	9,0	1	341.0250C	86,35
3/8	19	100	15	12,0	9,0	1	341.0375C	85,23
1/2	14	125	17	16,0	12,0	1	341.0500C	113,83
5/8	14	125	17	18,0	14,5	1	341.0625C	168,77
3/4	14	140	20	20,0	16,0	1	341.0750C	191,95

BSP	P	l ₁	l ₂	d ₂	a	St./VE	Art.nr.	€ / VE
7/8	14	150	22	22,0	18,0	1	341.0875C	236,05
1	11	160	24	25,0	20,0	1	341.1000C	266,54
1.1/4	11	170	25	32,0	24,0	1	341.1250C	532,02
1.1/2	11	190	27	36,0	29,0	1	341.1500C	1.082,83
2	11	220	40	45,0	35,0	1	341.2000C	1.508,80

323

HSS-E OPTI-LINE Machinetap, BSP, doorlopend



OPTI

Uitvoering: HSS-E machinetappen, DIN 5156, BSP (G, gasdraad), 55°, ISO2 (6H), type B met schilaansnijding.

Toepassing: Tappen van doorlopende gaten in (gelegeerd) staal <800 N/mm². Materiaalgroepen : 1.1 - 1.2 - 1.3 - 1.4



BSP	P	l ₁	l ₂	d ₂	a	St./VE	Art.nr.	€ / VE
1/8	28	90	18	7,0	5,5	1	323.0125	35,02
1/4	19	100	22	11,0	9,0	1	323.0250	59,91
3/8	19	100	22	12,0	9,0	1	323.0375	61,98

BSP	P	l ₁	l ₂	d ₂	a	St./VE	Art.nr.	€ / VE
1/2	14	125	25	16,0	12,0	1	323.0500	82,75
3/4	14	140	28	20,0	16,0	1	323.0750	139,67
1	11	160	30	25,0	20,0	1	323.1000	181,92

342

HSS-E Machinetap, BSPT, blind en doorlopend



Uitvoering: HSS-E machinetappen, DIN 5156, BSPT, 55°, coniciteit 1:16, type C.

Toepassing: Voor het tappen van blinde (1,5xD) en doorlopende gaten in (gelegeerd) staal <800 N/mm².
Materiaalgroepen : 1.1 - 1.2 - 1.3



BSPT	P	l ₁	l ₂	d ₂	a	St./VE	Art.nr.	€ / VE
1/8	28	90	20	7,0	5,5	1	342.0002	62,66
1/4	19	100	22	11,0	9,0	1	342.0004	90,69
3/8	19	100	22	12,0	9,0	1	342.0006	122,78

BSPT	P	l ₁	l ₂	d ₂	a	St./VE	Art.nr.	€ / VE
1/2	14	125	28	16,0	12,0	1	342.0008	212,93
3/4	14	140	28	20,0	16,0	1	342.0010	343,94
1	11	160	38	25,0	20,0	1	342.0012	363,18

343

HSS-E Machinetap, NPT, blind en doorlopend



Uitvoering: HSS-E machinetappen, NPT, 60°, coniciteit 1:16, type C met korte aansnijding.

Toepassing: Voor het tappen van blinde (1,5xD) en doorlopende gaten in (gelegeerd) staal <800 N/mm².
Materiaalgroepen : 1.1 - 1.2 - 1.3



NPT	P	l ₁	l ₂	d ₂	a	St./VE	Art.nr.	€ / VE
1/16	27	90	20	6,0	4,9	1	343.0020	84,54
1/8	27	90	20	7,0	5,5	1	343.0040	68,18
1/4	18	100	22	11,0	9,0	1	343.0060	68,52
3/8	18	100	22	12,0	9,0	1	343.0080	79,18

NPT	P	l ₁	l ₂	d ₂	a	St./VE	Art.nr.	€ / VE
1/2	14	125	28	16,0	12,0	1	343.0100	128,27
3/4	14	140	28	20,0	16,0	1	343.0120	231,13
1	11,5	160	38	25,0	20,0	1	343.0140	365,66

345

HSS-E Machinetap, PG, blind en doorlopend

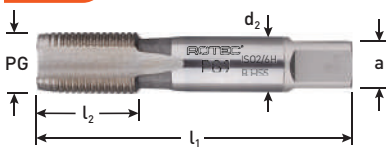

Uitvoering: HSS-E machinetappen, DIN 40430, Panzerrohr-Gewinde [PG], 80°, korte aansnijding.

Toepassing: Voor het tappen van blinde (1,5xD) en doorlopende gaten in (gelegeerd) staal <800 N/mm².
Materiaalgroepen : 1.1 - 1.2 - 1.3



PG	P	l ₁	l ₂	d ₂	a	St./VE	Art.nr.	€ / VE
7	20	70	22	9,0	7,0	1	345.0700	30,78
9	18	70	22	12,0	9,0	1	345.0900	41,02
11	18	80	22	14,0	11,0	1	345.1100	67,32
13,5	18	80	22	16,0	12,0	1	345.1350	80,14

PG	P	l ₁	l ₂	d ₂	a	St./VE	Art.nr.	€ / VE
16	18	80	22	18,0	14,5	1	345.1600	96,15
21	16	90	22	22,0	18,0	1	345.2100	163,01
29	16	100	25	28,0	22,0	1	345.2900	372,94
36	16	140	40	36,0	29,0	1	345.3600	805,34

356

HSS-E Machinetap, Trapezium (TR), doorlopend

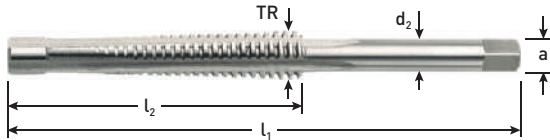

Uitvoering: HSS-E machinetap, trapezium [T], 30°, tolerantie 7H voor draadlengte 1xD.
Toepassing: Tappen van doorlopende gaten in (gelegeerd) staal <700 N/mm². Materiaalgroepen : 1.1 - 1.2 - 1.3



TR	P	l ₁	l ₂	d ₂	a	St./VE	Art.nr.	€ / VE
12	3	165	111	8	6,2	1	356.1200	547,76
14	3	140	85	10	8	1	356.1400	583,32
16	4	180	116	11	9	1	356.1600	638,23
18	4	190	120	12	9	1	356.1800	652,84

TR	P	l ₁	l ₂	d ₂	a	St./VE	Art.nr.	€ / VE
20	4	200	124	14	11	1	356.2000	679,43
22	5	235	155	16	12	1	356.2200	879,90
24	5	245	160	18	14,5	1	356.2400	1.012,30

355

HSS-E Combi-boor-tap, metrisch

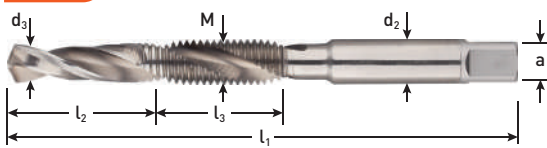

Uitvoering: Geschikt voor het boor en tappen in één bewerking. Cilindrische schachten met vierkant.
Toepassing: Voor doorlopende gaten.



M	p	d ₃	l ₁	l ₂	l ₃	d ₂	a	St./VE	Art.nr.	€ / VE
3	0,5	2,4	56	16	11	3,0	2,5	1	355.0300	31,48
4	0,7	3	63	18	14	4,0	3,3	1	355.0400	30,40
5	0,8	3,8	70	20	18	5,0	4,2	1	355.0500	30,40
6	1,0	4,9	80	22	22	6,0	5	1	355.0600	33,95
8	1,25	6,2	90	26	25	8,0	6,8	1	355.0800	39,13
10	1,5	8	100	30	31	10,0	8,5	1	355.1000	42,26
12	1,75	9	115	32	35	12,0	10,2	1	355.1200	50,07

316

HSS Combi-boor-/tapbit

ROTEC®

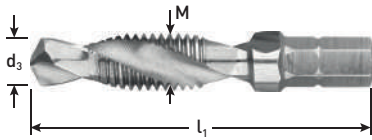

Uitvoering: HSS Combi-boortappen met 1/4"-bitaansluiting. Snel wisselen van gereedschap mogelijk in combinatie met 1/4" bithouder. Ook direct te gebruiken in een boorkop.

Toepassing: Boren, tappen en ontbramen in één arbeidsgang. Geschikt voor non-ferro, metaal en kunststof. Ideaal in combinatie met accu-gereedschap.



M	p	l ₁	d ₃	St./VE	Art.nr.	€ / VE
3	0,5	36	2,5	1	316.0300	16,56
4	0,7	39	3,3	1	316.0400	16,56
5	0,8	41	4,2	1	316.0500	16,56
6	1,0	44	5,0	1	316.0600	16,56
8	1,25	50	6,8	1	316.0800	16,74
10	1,5	59	8,5	1	316.1000	19,98

900

HSS Combi-boor-/tapbitset, in ABS-cassette

ROTEC®



Uitvoering: HSS Combi-boortappen met 1/4" (6,3mm) bitopname volgens DIN 3126-C6.3. Snel wisselen van gereedschap mogelijk in combinatie met 1/4" bithouder. Ook direct te gebruiken in een boorkop of accuboorschroefmachine.

Toepassing: Boren, tappen en ontbramen in één arbeidsgang. Geschikt voor non-ferro, metaal en kunststof.

Omschrijving	Type	Inhoud	St./VE	Art.nr.	€ / VE
7-dlg. set Combi-boor-tap-bits	316	1x M3, M4, M5, M6, M8 en M10 + bithouder	1	900.2030	106,56

360

HSS Ronde snijplaat, metrisch

ROTEC®



Uitvoering: HSS ronde snijplaat, DIN-EN 22568, metrisch.
Toepassing: Voor het snijden van draad in (gelegeerde) staalsoorten < 800 N/mm².
 Materiaalgroepen : 1.1 - 1.2 - 1.3 - 4.2



M	ρ	D ₁	H (mm)	St./VE	Art.nr.	€ / VE
2	0,4	16	5	1	360.0200	34,40
2,5	0,45	16	5	1	360.0250	37,50
3	0,5	20	5	1	360.0300	16,78
3,5	0,6	20	5	1	360.0350	20,21
4	0,7	20	5	1	360.0400	15,74
4,5	0,75	20	7	1	360.0450	20,21
5	0,8	20	7	1	360.0500	16,18
6	1,0	20	7	1	360.0600	16,18
7	1,0	25	9	1	360.0700	22,30
8	1,25	25	9	1	360.0800	18,24
9	1,25	25	9	1	360.0900	24,03
10	1,5	30	11	1	360.1000	23,26
11	1,5	30	11	1	360.1100	29,40

M	ρ	D ₁	H (mm)	St./VE	Art.nr.	€ / VE
12	1,75	38	14	1	360.1200	29,62
14	2,0	38	14	1	360.1400	29,62
16	2,0	45	18	1	360.1600	53,26
18	2,5	45	18	1	360.1800	53,26
20	2,5	45	18	1	360.2000	53,26
22	2,5	55	22	1	360.2200	109,69
24	3,0	55	22	1	360.2400	109,69
27	3,0	65	25	1	360.2700	169,75
30	3,5	65	25	1	360.3000	156,45
33	3,5	65	25	1	360.3300	176,83
36	4,0	65	25	1	360.3600	176,83
39	4,0	75	30	1	360.3900	238,75
42	4,5	75	30	1	360.4200	222,64

900

Snijplatenset, metrisch, in ABS-cassette

ROTEC®



Uitvoering: HSS ronde snijplaten, DIN-EN 22568, metrisch.
Toepassing: Voor het snijden van draad in (gelegeerde) staalsoorten < 800 N/mm².
 Materiaalgroepen : 1.1 - 1.2 - 1.3 - 4.2

Omschrijving	Type	Inhoud	St./VE	Art.nr.	€ / VE
7-dlg. Snijplatenset	360	HSS ronde snijplaten (360): 1x M3 / M4 / M5 / M6 / M8 / M10 / M12	1	900.2050	102,38

900

Snijplaten- en snijplaathoudersset, metrisch, in metalen koffer

ROTEC®



Uitvoering: HSS ronde snijplaten, DIN-EN 22568, metrisch.
Toepassing: Voor het snijden van draad in (gelegeerde) staalsoorten < 800 N/mm².
 Materiaalgroepen : 1.1 - 1.2 - 1.3 - 4.2

Omschrijving	Inhoud	St./VE	Art.nr.	€ / VE
12-dlg. Snijplatenset	HSS ronde snijplaten (360): 1x M3 / M4 / M5 / M6 / M8 / M10 / M12 Snijplaathouders: 1x 20x5, 20x7, 25x9, 30x11 en 38x14	1	900.2025	179,38

360 HSS-E Ronde snijplaat 'INOX', metrisch



INOX

Uitvoering: HSS-E ronde snijplaten, DIN-EN 22568, metrisch, stoomontlaten, extra gelegeerd, type B: met schilaansnijding.

Toepassing: Voor het snijden van draad in roestvaststaal en (gelegeerd) staal < 1.000 N/mm².
Materiaalgroepen : 1.1 - 1.2 - 1.3 - 1.4 - 2.1 - 2.2 - 4.2 - 4.3



M	p	D ₁	H (mm)	St./VE	Art.nr.	€ / VE
3	0,5	20	5	1	360.0300B	33,58
4	0,7	20	5	1	360.0400B	31,57
5	0,8	20	7	1	360.0500B	32,29
6	1,0	20	7	1	360.0600B	32,29
8	1,25	25	9	1	360.0800B	34,86
10	1,5	30	11	1	360.1000B	44,54
12	1,75	38	14	1	360.1200B	56,73
14	2,0	38	14	1	360.1400B	56,73

M	p	D ₁	H (mm)	St./VE	Art.nr.	€ / VE
16	2,0	45	18	1	360.1600B	102,27
18	2,5	45	18	1	360.1800B	102,27
20	2,5	45	18	1	360.2000B	102,27
22	2,5	55	22	1	360.2200B	193,10
24	3,0	55	22	1	360.2400B	193,10
27	3,0	65	25	1	360.2700B	298,86
30	3,5	65	25	1	360.3000B	358,59

HSS Ronde snijplaat, metrisch links



Uitvoering: HSS ronde snijplaten, DIN-EN 22568, metrisch, links.

Toepassing: Voor het snijden van draad in (gelegerde) staalsoorten < 800 N/mm².
Materiaalgroepen : 1.1 - 1.2 - 1.3 - 4.2



M	p	D ₁	H (mm)	St./VE	Art.nr.	€ / VE
3	0,5	20	5	1	360.0300L	26,99
4	0,7	20	5	1	360.0400L	20,50
5	0,8	20	7	1	360.0500L	22,87
6	1,0	20	7	1	360.0600L	22,87
8	1,25	25	9	1	360.0800L	25,77

M	p	D ₁	H (mm)	St./VE	Art.nr.	€ / VE
10	1,5	30	11	1	360.1000L	33,09
12	1,75	38	14	1	360.1200L	42,29
16	2,0	45	18	1	360.1600L	104,43
20	2,5	45	18	1	360.2000L	100,22

361

HSS Ronde snijplaat, metrisch fijn



Uitvoering: HSS ronde snijplaten, DIN - EN 22568, metrisch fijn.
Toepassing: Voor het snijden van draad in (gelegeerde) staalsoorten < 800 N/mm².
 Materiaalgroepen : 1.1 - 1.2 - 1.3 - 4.2



MF	p	D ₁	H (mm)	St./VE	Art.nr.	€/VE
3	0,35	20	5	1	361.0303	25,69
4	0,5	20	5	1	361.0405	26,49
5	0,5	20	5	1	361.0505	27,83
6	0,5	20	5	1	361.0605	26,09
6	0,75	20	7	1	361.0607	25,81
7	0,75	25	9	1	361.0707	29,74
8	0,50	25	9	1	361.0805	27,99
8	0,75	25	9	1	361.0807	28,22
8	1,0	25	9	1	361.0810	28,22
9	1,0	25	9	1	361.0910	37,81
10	0,50	30	11	1	361.1005	35,84
10	0,75	30	11	1	361.1007	36,29
10	1,0	30	11	1	361.1010	33,72
10	1,25	30	11	1	361.1012	31,61
12	0,50	38	10	1	361.1205	42,30
12	0,75	38	10	1	361.1207	42,30
12	1,0	38	10	1	361.1210	40,59
12	1,25	38	10	1	361.1212	40,59
12	1,5	38	10	1	361.1215	42,61
13	1,0	38	10	1	361.1310	60,91
13	1,5	38	10	1	361.1315	60,91
14	1,0	38	10	1	361.1410	42,42
14	1,25	38	10	1	361.1412	40,85
14	1,5	38	10	1	361.1415	40,59
15	1,0	38	10	1	361.1510	65,24
15	1,5	38	10	1	361.1515	65,24
16	1,0	45	14	1	361.1610	61,61
16	1,5	45	14	1	361.1615	58,43

MF	p	D ₁	H (mm)	St./VE	Art.nr.	€/VE
17	1,0	45	14	1	361.1710	88,96
18	1,0	45	14	1	361.1810	61,61
18	1,25	45	14	1	361.1812	60,81
18	1,5	45	14	1	361.1815	58,43
18	2,0	45	14	1	361.1820	60,81
20	1,0	45	14	1	361.2010	61,61
20	1,5	45	14	1	361.2015	58,43
20	2,0	45	14	1	361.2020	60,81
22	1,0	55	16	1	361.2210	97,86
22	1,5	55	16	1	361.2215	92,05
22	2,0	55	16	1	361.2220	99,36
24	1,0	55	16	1	361.2410	97,86
24	1,5	55	16	1	361.2415	92,05
24	2,0	55	16	1	361.2420	95,85
25	1,5	55	16	1	361.2515	153,00
26	1,5	55	16	1	361.2615	153,00
27	1,0	65	18	1	361.2710	174,37
27	1,5	65	18	1	361.2715	142,13
27	2,0	65	18	1	361.2720	161,47
30	1,0	65	18	1	361.3010	145,30
30	1,5	65	18	1	361.3015	148,61
30	2,0	65	18	1	361.3020	168,07
32	1,5	65	18	1	361.3215	174,37
32	2,0	65	18	1	361.3220	156,03
33	1,5	65	18	1	361.3315	145,56
36	1,5	65	18	1	361.3615	145,30
42	2,0	75	20	1	361.4220	231,30
50	1,5	90	22	1	361.5015	370,68

363

HSS Ronde snijplaat, UNC

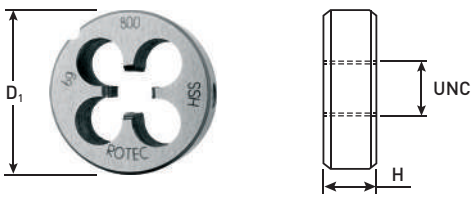

Uitvoering: HSS ronde snijplaten, DIN-EN 22568, UNC.
Toepassing: Voor het snijden van draad in (gelegeerde) staalsoorten < 800 N/mm².
 Materiaalgroepen : 1.1 - 1.2 - 1.3 - 4.2



UNC	P	D ₁	H (mm)	St./VE	Art.nr.	€/VE
1/4	20	20	7	1	363.0014	24,12
5/16	18	25	9	1	363.0016	33,59
3/8	16	30	11	1	363.0018	37,35
7/16	14	30	11	1	363.0020	42,60
1/2	13	38	14	1	363.0022	48,43

UNC	P	D ₁	H (mm)	St./VE	Art.nr.	€/VE
9/16	12	38	14	1	363.0024	59,56
5/8	11	45	18	1	363.0026	65,13
3/4	10	45	18	1	363.0028	65,13
7/8	9	55	22	1	363.0030	123,18
1	8	55	22	1	363.0032	123,18

364

HSS Ronde snijplaat, UNF

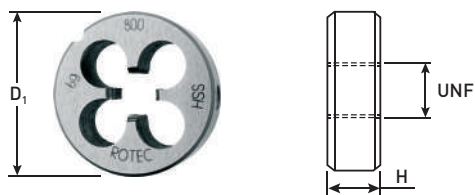

Uitvoering: HSS ronde snijplaten, DIN-EN 22568, UNF.

Toepassing: Voor het snijden van draad in (gelegeerde) staalsoorten < 800 N/mm².
Materiaalgroepen : 1.1 - 1.2 - 1.3 - 4.2



UNF	P	D ₁	H (mm)	St./VE	Art.nr.	€ / VE
1/4	28	20	7	1	364.0014	29,80
5/16	24	25	9	1	364.0016	33,59
3/8	24	30	11	1	364.0018	37,35
7/16	20	30	11	1	364.0020	42,60
1/2	20	38	10	1	364.0022	48,43

UNF	P	D ₁	H (mm)	St./VE	Art.nr.	€ / VE
9/16	18	38	10	1	364.0024	59,56
5/8	18	45	14	1	364.0026	65,13
3/4	16	45	14	1	364.0028	65,13
7/8	14	55	16	1	364.0030	98,07
1	12	55	16	1	364.0032	123,18

365

HSS Ronde snijplaat, BSP (Gasdraad)

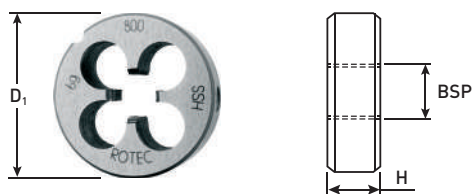

Uitvoering: HSS ronde snijplaten, DIN-EN 24231, BSP (gasdraad).

Toepassing: Voor het snijden van draad in (gelegeerde) staalsoorten < 800 N/mm².
Materiaalgroepen : 1.1 - 1.2 - 1.3 - 4.2



BSP	P	D ₁	H (mm)	St./VE	Art.nr.	€ / VE
1/8	28	30	11	1	365.0125	29,81
1/4	19	38	10	1	365.0250	31,52
3/8	19	45	14	1	365.0375	47,50
1/2	14	45	14	1	365.0500	47,50

BSP	P	D ₁	H (mm)	St./VE	Art.nr.	€ / VE
5/8	14	55	16	1	365.0625	94,94
3/4	14	55	16	1	365.0750	131,62
7/8	14	65	18	1	365.0875	131,37
1	11	65	18	1	365.1000	155,72

367

HSS Ronde snijplaat, NPT

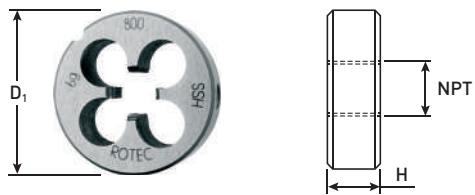

Uitvoering: HSS ronde snijplaten, DIN-EN 24230, NPT.

Toepassing: Voor het snijden van draad in (gelegeerde) staalsoorten < 800 N/mm².
Materiaalgroepen : 1.1 - 1.2 - 1.3 - 4.2



NPT	P	D ₁	H (mm)	St./VE	Art.nr.	€ / VE
1/16	27	25	9	1	367.0010	70,32
1/8	27	30	11	1	367.0012	43,03
1/4	18	38	14	1	367.0014	47,86
3/8	18	45	14	1	367.0016	86,03

NPT	P	D ₁	H (mm)	St./VE	Art.nr.	€ / VE
1/2	14	45	18	1	367.0018	86,03
3/4	14	55	22	1	367.0022	172,24
1	11,5	65	25	1	367.0026	327,37

370

HSS Zeskante snijmoer, metrisch

Uitvoering: HSS zeskante snijmoer, DIN 382, metrisch.
Toepassing: Voor het (op)snijden van draad in (gelegeerde) staalsoorten < 800 N/mm².
 Materiaalgroepen : 1.1 - 1.2 - 1.3 - 4.2



M	p	S ₁	H (mm)	St./VE	Art.nr.	€ / VE
3	0,5	19	5	1	370.0300	31,00
4	0,7	19	5	1	370.0400	31,00
5	0,8	19	7	1	370.0500	31,00
6	1,0	19	7	1	370.0600	31,00
7	1,0	22	9	1	370.0700	31,52
8	1,25	22	9	1	370.0800	33,28
10	1,5	27	11	1	370.1000	39,48
12	1,75	36	14	1	370.1200	54,80

M	p	S ₁	H (mm)	St./VE	Art.nr.	€ / VE
14	2,0	36	14	1	370.1400	54,80
16	2,0	41	18	1	370.1600	77,32
18	2,5	41	18	1	370.1800	73,24
20	2,5	41	18	1	370.2000	77,32
22	2,5	50	22	1	370.2200	122,36
24	3,0	50	22	1	370.2400	158,20
27	3,0	60	25	1	370.2700	257,18
30	3,5	60	25	1	370.3000	238,13

900

Snijmoerset, metrisch, in ABS-cassette

Uitvoering: HSS zeskante snijmoer, DIN 382, metrisch.
Toepassing: Voor het (op)snijden van draad in (gelegeerde) staalsoorten < 800 N/mm².
 Materiaalgroepen : 1.1 - 1.2 - 1.3 - 4.2



Omschrijving	Type	Inhoud	St./VE	Art.nr.	€ / VE
7-dlg. Set snijmoeren	370	1x M3, M4, M5, M6, M8, M10 en M12	1	900.2055	186,19

371

HSS Zeskante snijmoer, metrisch fijn



Uitvoering: HSS zeskante snijmoer, DIN 382, metrisch fijn.
Toepassing: Voor het (op)snijden van draad in (gelegeerde) staalsoorten < 800 N/mm².
 Materiaalgroepen : 1.1 - 1.2 - 1.3 - 4.2

MF	p	S ₁	H (mm)	St./VE	Art.nr.	€ / VE
3	0,35	19	5	1	371.0303	59,71
4	0,5	19	5	1	371.0405	59,71
5	0,5	19	7	1	371.0505	59,71
6	0,75	19	7	1	371.0607	59,71
8	0,75	22	9	1	371.0807	63,61
8	1,0	22	9	1	371.0810	63,61
10	1,0	27	11	1	371.1010	60,26
10	1,25	27	11	1	371.1012	63,61
12	1,0	36	10	1	371.1210	83,42
12	1,25	36	10	1	371.1212	83,42
12	1,5	36	14	1	371.1215	88,07
14	1,25	36	10	1	371.1412	99,50
14	1,5	36	14	1	371.1415	99,50
15	1,0	36	10	1	371.1510	119,38
16	1,0	41	14	1	371.1610	122,34
16	1,5	41	14	1	371.1615	122,34
18	1,0	41	14	1	371.1810	129,17
18	1,25	41	14	1	371.1812	129,17

MF	p	S ₁	H (mm)	St./VE	Art.nr.	€ / VE
18	1,5	41	14	1	371.1815	129,17
20	1,0	41	14	1	371.2010	129,17
20	1,5	41	14	1	371.2015	129,17
20	2,0	41	14	1	371.2020	129,17
22	1,5	50	16	1	371.2215	176,73
24	1,0	50	16	1	371.2410	186,57
24	1,5	50	16	1	371.2415	186,57
24	2,0	50	16	1	371.2420	186,57
25	1,5	50	16	1	371.2515	270,74
26	1,5	50	16	1	371.2615	270,74
27	1,5	60	18	1	371.2715	280,53
27	2,0	60	18	1	371.2720	280,53
28	1,5	60	18	1	371.2815	280,53
30	1,5	60	18	1	371.3015	280,53
30	2,0	60	18	1	371.3020	280,53
32	1,5	60	18	1	371.3215	280,53
32	2,0	60	18	1	371.3220	280,53

373

HSS Zeskante snijmoer, UNC

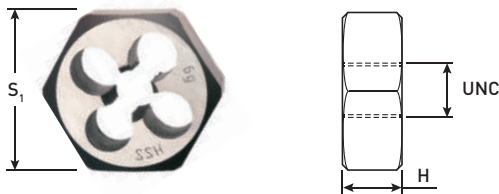

Uitvoering: HSS zeskante snijmoer, DIN 382, UNC.
Toepassing: Voor het (op)snijden van draad in (gelegeerde) staalsoorten < 800 N/mm².
 Materiaalgroepen : 1.1 - 1.2 - 1.3 - 4.2

UNC	P	S ₁	H (mm)	St./VE	Art.nr.	€ / VE
1/4	20	19	7	1	373.0014	37,40
5/16	18	22	9	1	373.0016	38,94
3/8	16	27	11	1	373.0018	46,35
7/16	14	27	11	1	373.0020	48,93
1/2	13	36	14	1	373.0022	56,56

UNC	P	S ₁	H (mm)	St./VE	Art.nr.	€ / VE
9/16	12	36	14	1	373.0024	59,71
5/8	11	41	18	1	373.0026	82,86
3/4	10	41	18	1	373.0028	86,34
7/8	9	50	22	1	373.0030	169,62
1	8	50	22	1	373.0032	169,62

374

HSS Zeskante snijmoer, UNF

Uitvoering: HSS zeskante snijmoer, DIN 382, UNF.
Toepassing: Voor het (op)snijden van draad in (gelegeerde) staalsoorten < 800 N/mm².
 Materiaalgroepen : 1.1 - 1.2 - 1.3 - 4.2

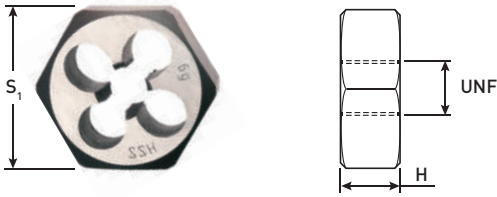

UNF	P	S ₁	H (mm)	St./VE	Art.nr.	€ / VE
1/4	28	19	7	1	374.0014	39,48
5/16	24	22	9	1	374.0016	38,94
3/8	24	27	11	1	374.0018	46,35
7/16	20	27	11	1	374.0020	48,93
1/2	20	36	14	1	374.0022	56,56

UNF	P	S ₁	H (mm)	St./VE	Art.nr.	€ / VE
9/16	18	36	14	1	374.0024	59,71
5/8	18	41	18	1	374.0026	78,49
3/4	16	41	18	1	374.0028	82,86
7/8	14	50	22	1	374.0030	160,68
1	12	50	22	1	374.0032	169,62

377

HSS Zeskante snijmoer, BSP (Gasdraad)

Uitvoering: HSS zeskante snijmoer, DIN 382, BSP (gasdraad).
Toepassing: Voor het (op)snijden van draad in (gelegeerde) staalsoorten < 800 N/mm².
 Materiaalgroepen : 1.1 - 1.2 - 1.3 - 4.2

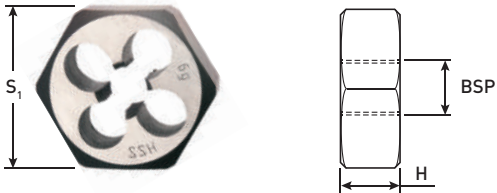

BSP	P	S ₁	H (mm)	St./VE	Art.nr.	€ / VE
1/8	28	27	10	1	377.0125	49,90
1/4	19	36	10	1	377.0250	58,10
3/8	19	41	14	1	377.0375	114,01
1/2	14	41	14	1	377.0500	114,01
5/8	14	50	16	1	377.0625	145,31

BSP	P	S ₁	H (mm)	St./VE	Art.nr.	€ / VE
3/4	14	50	16	1	377.0750	145,31
1	11	60	18	1	377.1000	193,75
1.1/4	11	70	20	1	377.1250	303,69
1.1/2	11	85	22	1	377.1500	498,91

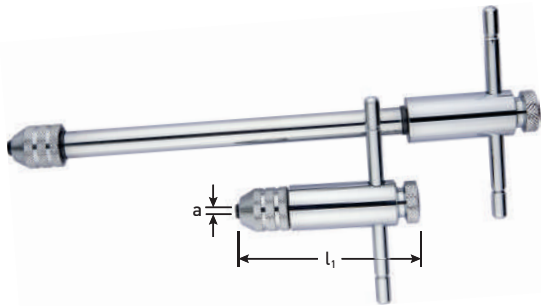

Uitvoering: Links en rechtsdraaiend.

Nr.	d (min-max)	a (min-max)	l ₁	St./VE	Art.nr.	€ / VE
1	M3 - M10	2,4 - 5,5	85	1	380.0001	21,58
2	M5 - M12	4,5 - 8,0	100	1	380.0002	26,50
10	M3 - M10	2,4 - 5,5	250	1	380.0010	38,96
20	M5 - M12	4,5 - 7,0	300	1	380.0020	47,61

Verstelbaar wringijzer, aluminium

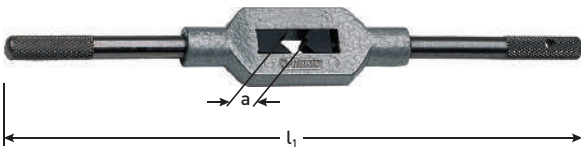

Uitvoering: Verstelbaar wringijzer, DIN 1814, vervaardigd uit aluminium-zink legering met stalen bekken.

Nr.	d (min-max)	a (min-max)	l ₁	St./VE	Art.nr.	€ / VE
0	M1 - M 8	2,0 - 5,0	130	1	380.1000	9,22
1	M1 - M10	2,0 - 6,3	176	1	380.1010	10,86
1½	M1 - M12	2,1 - 8,0	176	1	380.1015	11,23
2	M4 - M12	3,0 - 9,0	280	1	380.1020	18,12
3	M5 - M20	4,9 - 12,0	380	1	380.1030	33,25
4	M11 - M27	5,5 - 16,0	505	1	380.1040	54,14
5L	M13 - M32	7,0 - 20,0	700	1	380.1050	84,68

Verstelbaar wringijzer, staal

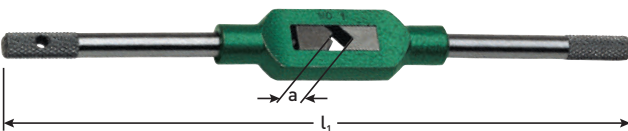

Uitvoering: Verstelbaar wringijzer, DIN 1814, vervaardigd uit staal, met stalen bekken.

Nr.	d (min-max)	a (min-max)	l ₁	St./VE	Art.nr.	€ / VE
0	M1 - M 8	2,0 - 5,0	130	1	380.1100	16,65
1	M1 - M10	2,0 - 6,3	176	1	380.1110	18,69
1½	M1 - M12	2,1 - 8,0	176	1	380.1115	18,69
2	M4 - M12	3,0 - 9,0	280	1	380.1120	31,57
3	M5 - M20	4,9 - 12,0	380	1	380.1130	59,66
4	M11 - M27	5,5 - 16,0	505	1	380.1140	106,57
5	M13 - M32	7,0 - 20,0	700	1	380.1150	157,03
6	M18 - M42	11,0 - 24,0	1.000	1	380.1160	201,85
7	M25 - M52	16,0 - 32,0	1.250	1	380.1170	307,19
8	M25 - M64	16,0 - 40,0	1.250	1	380.1180	717,62

Snijplaathouder

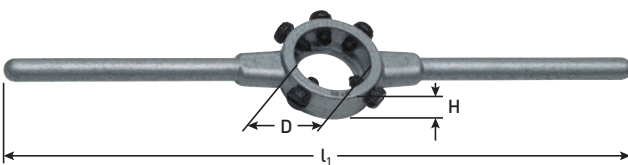

Uitvoering: Snijplaathouder, DIN 225, vervaardigd uit aluminium-zink legering, voor snijplaat DIN - EN 22 568.

D x H	d (min-max)	l ₁	St./VE	Art.nr.	€ / VE
16 x 5	M1 - 2,6	160	1	380.1605	8,18
20 x 5	M3 - 4	200	1	380.2005	8,51
20 x 7	M4,5 - 6	200	1	380.2007	8,38
25 x 9	M7 - 9	224	1	380.2509	9,91
30 x 11	M10 - 11	280	1	380.3011	14,10
38 x 10	MF12 - 14	315	1	380.3810	20,97
38 x 14	M12 - 14	315	1	380.3814	20,97
45 x 14	MF16 - 20	450	1	380.4514	27,15
45 x 18	M16 - 20	450	1	380.4518	27,15
55 x 16	MF22 - 24	560	1	380.5516	37,42
55 x 22	M22 - 24	560	1	380.5522	37,42
65 x 18	MF27 - 36	630	1	380.6518	63,07
65 x 25	M27 - 36	630	1	380.6525	69,35

Tapverlengstuk

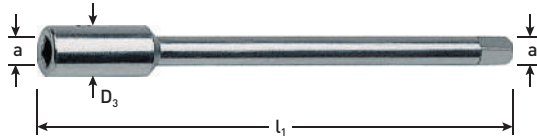

Uitvoering: Tapverlengstuk, DIN 377, vierkant volgens DIN 10, cilindrische schacht, gehard en geslepen.

Toepassing: Hulpstuk om tappen te kunnen verlengen.

a	D ₃	L ₁	St./VE	Art.nr.	€ / VE
2,1	5	60	1	380.0021	8,97
2,7	7	80	1	380.0027	9,35
3,0	7	90	1	380.0030	9,35
3,4	8	95	1	380.0034	9,35
3,8	9	100	1	380.0038	11,22
4,3	10	105	1	380.0043	13,59
4,9	11	110	1	380.0049	10,11
5,5	12	115	1	380.0055	11,44
6,2	14	120	1	380.0062	13,08
7,0	15	125	1	380.0070	15,50
8,0	17	125	1	380.0080	20,24
9,0	19	130	1	380.0090	22,10
10,0	21	140	1	380.0100	29,22
12,0	25	155	1	380.0120	46,39
14,5	29	175	1	380.0145	61,01

Tapeinduithalerset



Omschrijving	Nr.	d (min-max)	Inhoud	St./VE	Art.nr.	€ / VE
5-dlg. tapeinduithalerset	1 - 5	M3 - M18	1x No. 1, 2, 3, 4 en 5	1	380.9000	12,57
5-dlg. tapeinduithalerset	1 - 5	M3 - M18	1x No. 1, 2, 3, 4 en 5	1	380.9001	14,00
6-dlg. tapeinduithalerset	1 - 6	M3 - M24	1x No. 1, 2, 3, 4, 5 en 6	1	380.9002	20,00
8-dlg. tapeinduithalerset	1 - 8	M3 - M50	1x No. 1, 2, 3, 4, 5, 6, 7 en 8	1	380.9003	52,91

385

Ro-Coil HSS Eindsnijder, metrisch [M]

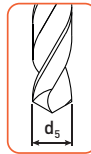
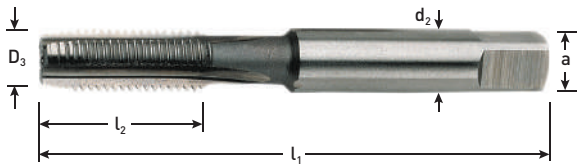

Uitvoering: Ro-Coil HSS eindsnijder, metrisch [M], 60°, tolerantie ISO 2 (6H), voor Ro-Coil draadinserts.

Toepassing: Voor handmatig passend tappen van gaten voor het plaatsen van Ro-Coils in non-ferro's en zachte staalsoorten.

Geschikt voor	p	D ₃	l ₁	l ₂	d ₂	a	d ₅	St./VE	Art.nr.	€ / VE
M3	0,5	3,6	53	13	4	3,15	3,2	1	385.0300	15,30
M4	0,7	4,9	58	16	5	4	4,2	1	385.0400	15,30
M5	0,8	6,0	66	19	6,3	5	5,2	1	385.0500	21,04
M6	1	7,3	72	22	8	6,3	6,3	1	385.0600	22,36
M7	1	8,3	72	22	9	7,1	7,3	1	385.0700	27,08
M8	1,25	9,6	80	24	10	8	8,3	1	385.0800	21,13
M10	1,5	11,9	89	29	9,0	7,1	10,4	1	385.1000	33,99
M12	1,75	14,3	95	30	11,2	9	12,4	1	385.1200	51,36
M14	2	16,6	102	32	12,5	10	14,5	1	385.1400	61,07
M16	2	18,6	112	37	14	11,2	16,5	1	385.1600	63,83
M18	2,5	21,3	118	38	16	12,5	18,6	1	385.1800	52,19
M20	2,5	23,3	118	38	16	12,5	20,6	1	385.2000	54,04
M24	3	27,9	138	48	20	16	24,75	1	385.2400	78,51

Ro-Coil HSS Eindsnijder, metrisch fijn [MF]

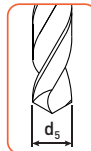

Uitvoering: Ro-Coil HSS eindsnijder, metrisch fijn [MF], 60°, tolerantie ISO 2 (6H), voor Ro-Coil draadinserts.

Toepassing: Voor handmatig passend tappen van gaten voor het plaatsen van Ro-Coils in non-ferro's en zachte staalsoorten.

Geschikt voor	p	D ₃	l ₁	l ₂	d ₂	a	d ₅	St./VE	Art.nr.	€ / VE
MF8	1	9,3	80	24	10	8	8,3	1	385.0810	27,08
MF10	1,25	11,6	85	25	8	6,3	10,3	1	385.1012	26,69
MF10	1	11,3	85	25	8	6,3	10,3	1	385.1010	33,99
MF12	1,5	14,0	95	30	11,2	9	12,4	1	385.1215	49,92
MF12	1,25	13,6	95	30	11,2	9	12,3	1	385.1212	49,92
MF12	1	13,3	95	30	11,2	9	12,3	1	385.1210	40,05
MF14	1,5	16,0	102	32	12,5	10	14,4	1	385.1415	61,07
MF14	1,25	15,6	102	32	12,5	10	14,3	1	385.1412	47,82
MF16	1,5	18,0	104	29	14	11,2	16,4	1	385.1615	50,03

386

Ro-Coil HSS Eindsnijder, UNC

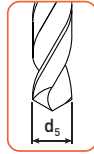
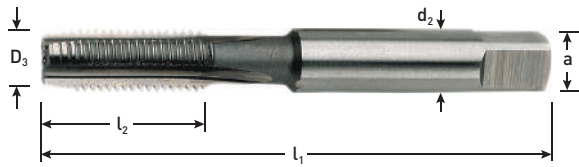

Uitvoering: Ro-Coil HSS eindsnijder, UNC, 60°, tolerantie 2B, voor Ro-Coil draadinserts.
Toepassing: Voor handmatig passend tappen van gaten voor het plaatsen van Ro-Coils in non-ferro's en zachte staalsoorten.

Geschikt voor	P	D ₃	l ₁	l ₂	d ₂	a	d ₅	St./VE	Art.nr.	€ / VE
No. 10	24	6,2	66	19	6,3	5	5,1	1	386.0120	20,86
1/4	20	8,0	72	22	8	6,3	6,7	1	386.0140	13,74
5/16	18	9,8	80	24	10	8	8,3	1	386.0160	14,96
3/8	16	11,6	85	25	8	6,3	9,9	1	386.0180	16,47
7/16	14	13,5	95	30	11,2	9	11,6	1	386.0200	20,86
1/2	13	15,2	102	32	12,5	10	13	1	386.0220	23,73
5/8	11	18,9	112	37	14	11,2	16,5	1	386.0260	48,65

386

Ro-Coil HSS Eindsnijder, UNF

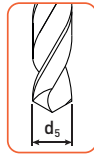
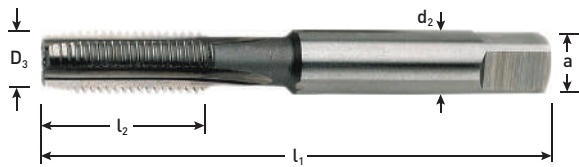

Uitvoering: Ro-Coil HSS eindsnijder, UNF, 60°, tolerantie 2B, voor Ro-Coil draadinserts.
Toepassing: Voor handmatig passend tappen van gaten voor het plaatsen van Ro-Coils in non-ferro's en zachte staalsoorten.

Geschikt voor	P	D ₃	l ₁	l ₂	d ₂	a	d ₅	St./VE	Art.nr.	€ / VE
No. 10	32	5,9	66	19	6,3	5	5,1	1	386.1012	20,86
1/4	28	7,5	69	19	8	6,3	6,6	1	386.1140	13,74
5/16	24	9,3	76	20	10	8	8,2	1	386.1160	14,96
3/8	24	10,9	82	22	8	6,3	9,8	1	386.1180	16,47
7/16	20	12,8	84	24	9	7,1	11,5	1	386.1200	20,86
1/2	20	14,4	90	25	11,2	9	13,0	1	386.1220	23,73
5/8	18	17,7	104	29	14	11,2	16,25	1	386.1260	48,65

387

Ro-Coil HSS Eindsnijder, BSP (G)

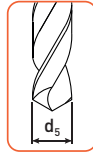
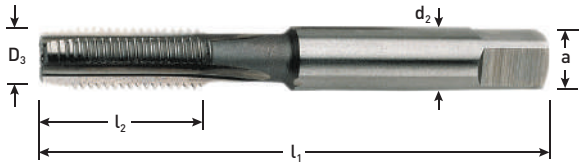

Uitvoering: Ro-Coil HSS eindsnijder, BSP (G), 55°, tolerantie ISO 2 (6H), voor Ro-Coil draadinserts.

Toepassing: Voor handmatig passend tappen van gaten voor het plaatsen van Ro-Coils in non-ferro's en zachte staalsoorten.

Geschikt voor	P	D ₃	l ₁	l ₂	d ₂	a	d ₅	St./VE	Art.nr.	€ / VE
1/8	28	10,8	59	15	8	6,3	10	1	387.0125	25,86
1/4	19	14,7	67	19	11,2	9	13,6	1	387.0250	32,32
3/8	19	18,3	75	21	14	11,2	17,1	1	387.0375	42,42
1/2	14	23,1	87	26	16	12,5	21,5	1	387.0500	69,18
5/8	14	25,0	91	26	18	14	23,4	1	387.0625	101,81
3/4	14	28,6	96	28	20	16	27	1	387.0750	101,81
1	11	36,0	109	33	25	20	33,7	1	387.1000	161,83

102

HSS-G Spiraalboor, type HD-S, GOLD-LINE

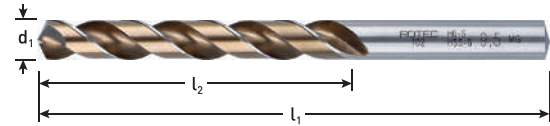

Uitvoering: HSS-G Spiraalboor, stabiel, geslepen, DIN 338, kort, type HD-S, kernversterkt, tophoek 130°, splitpoint / kruisaanslijping (DIN 1412-C). **Powered by Werkö.**

Toepassing: Voor algemeen gebruik maar door kern versterkte spiraal ook toe te passen op CNC-machines in meest voorkomende materialen zoals staal < 1.000 N/mm², gietstaal, (nodulair) gietijzer, nieuwzilver, grafiet, etc.
Materiaalgroepen : 1.1 - 1.4 / 3.1 - 3.3 / 4-2 - 4.12

d ₁	l ₁	l ₂	St./VE	Art.nr.	€ / VE
3,2	65	36	10	102.0320	24,21
4,2	75	43	10	102.0420	27,51
5,1	86	52	10	102.0510	33,17
5,2	86	52	10	102.0520	33,17
6,3	101	63	10	102.0630	42,65
6,6	101	63	10	102.0660	45,63
6,7	101	63	10	102.0670	60,70
7,3	109	69	10	102.0730	74,07
8,2	117	75	5	102.0820	33,43
8,3	117	75	5	102.0830	35,75

d ₁	l ₁	l ₂	St./VE	Art.nr.	€ / VE
9,8	133	87	5	102.0980	50,79
9,9	133	87	5	102.0990	50,79
10,0	133	87	5	102.1000	44,09
10,3	133	87	5	102.1030	63,98
10,4	133	87	5	102.1040	63,98
11,5	142	94	5	102.1150	71,29
12,3	151	101	5	102.1230	99,83
12,4	151	101	5	102.1240	104,72
13,0	151	101	5	102.1300	97,71



Toepassing: Draadinzetter voor het plaatsen van Ro-Coils.

Nr.	M / MF	UNC / UNF	St./VE	Art.nr.	€ / VE
Nr. 4	M3 x 0,5		1	390.9304	13,49
Nr. 6	M4 x 0,7		1	390.9306	13,49
Nr. 7		UNC No. 10 x 24	1	390.9307	13,49
Nr. 8	M5 x 0,8	UNF No. 10 x 32	1	390.9308	13,49
Nr. 9	M6 x 1,0	UNC 1/4 x 20 UNF 1/4 x 28	1	390.9309	13,49
Nr. 10	M7 x 1,0	UNC 5/16 x 18	1	390.9310	15,45
Nr. 11	M8 x 1,25 MF8 x 1,0	UNF 5/16 x 24	1	390.9311	15,45
Nr. 12		UNC 3/8 x 16	1	390.9312	16,60
Nr. 13	M10 x 1,5 MF10 x 1,25 MF10 x 1,0	UNF 3/8 x 24	1	390.9313	16,60
Nr. 15	M12 x 1,75 MF12 x 1,5 M12 x 1,25 MF12 x 1,0	UNC 1/2 x 13 UNF 1/2 x 20	1	390.9315	19,46

Nr.	M / MF	UNC / UNF	St./VE	Art.nr.	€ / VE
Nr. 16	M14 x 2,0 MF14 x 1,5		1	390.9316	23,25
Nr. 17	MF14 x 1,25 MF14 x 1,0		1	390.9317	23,25
Nr. 18	M16 x 2,0 MF16 x 1,5	UNC 5/8 x 11 UNF 5/8 x 18	1	390.9318	25,61
Nr. 20	M18 x 2,5 MF18 x 2,0 MF18 x 1,5		1	390.9320	25,61
Nr. 21	M20 x 2,5 MF20 x 2,0 MF20 x 1,5		1	390.9321	25,61
Nr. 23	M24x 3,0 MF24 x 2,0 MF24 x 1,5		1	390.9323	32,25

Ro-Coil Draadlipbreker



Toepassing: Voor het breken van de lip van de Ro-Coil nadat deze in het werkstuk geplaatst is. Vanaf M16 kan de draadlip met een punttang afgebroken worden. Bij blinde gaten kan het afbreken van de lip achterwege blijven mits rekening gehouden wordt met de maximale in-schroefdiepte.

Nr.	M / MF	UNC / UNF	St./VE	Art.nr.	€ / VE
Nr. 4	M3 x 0,5		1	390.9403	5,71
Nr. 6	M4 x 0,7	UNC No. 10 x 24	1	390.9404	6,00
Nr. 8	M5 x 0,8	UNF No. 10 x 32	1	390.9405	6,00
Nr. 9	M6 x 1,0	UNC 1/4 x 20 UNF 1/4 x 28	1	390.9406	6,00
Nr. 11	M7 x 1,0 M8 x 1,25 MF8 x 1,0	UNC 5/16 x 18 UNF 5/16 x 24	1	390.9408	6,70
Nr. 12		UNC 3/8 x 16	1	390.9409	6,70

Nr.	M / MF	UNC / UNF	St./VE	Art.nr.	€ / VE
Nr. 13	M10 x 1,5 MF10 x 1,25 MF10 x 1,0	UNF 3/8 x 24	1	390.9410	6,70
Nr. 15	M12 x 1,75 MF12 x 1,5 MF12 x 1,25 MF12 x 1,0	UNC 1/2 x 13 UNF 1/2 x 20	1	390.9412	8,09

389

Ro-Coil draadinsert, metrisch [M]

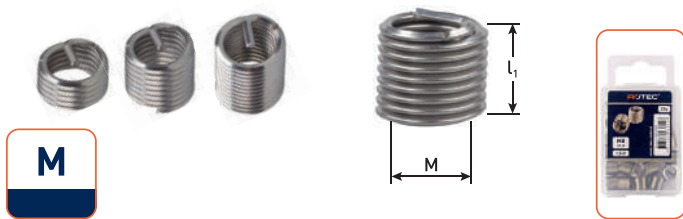

M

Uitvoering: Ro-Coil draadinsert, vervaardigd uit hoogwaardig RVS, temperatuur- en corrosiebestendig.

Toepassing: Schroefdraadbescherming in de wat zachtere metaalsoorten zoals: aluminium- en magnesium legeringen. Veel toegepast in automobielindustrie, machinebouw, elektro- en medische techniek alsook in de lucht- en ruimtevaartindustrie.

d ₁	p	l ₁	St./VE	Art.nr.	€ / VE
M3	0,5	1xD	25	389.0300	9,50
M4	0,7	1xD	25	389.0400	9,50
M5	0,8	1xD	25	389.0500	10,75
M6	1,0	1xD	25	389.0600	11,25
M7	1,0	1xD	25	389.0700	13,25
M8	1,25	1xD	25	389.0800	12,00
M10	1,5	1xD	25	389.1000	15,50
M12	1,75	1xD	25	389.1200	22,50
M14	2,0	1xD	10	389.1401	13,40
M16	2,0	1xD	10	389.1602	17,30

M3	0,5	1,5xD	25	389.0301	10,00
M4	0,7	1,5xD	25	389.0401	10,00
M5	0,8	1,5xD	25	389.0501	9,00
M6	1,0	1,5xD	25	389.0601	9,50
M7	1,0	1,5xD	25	389.0701	15,50
M8	1,25	1,5xD	25	389.0801	12,00
M10	1,5	1,5xD	25	389.1001	16,50
M12	1,75	1,5xD	25	389.1201	26,25
M14	2,0	1,5xD	10	389.1400	14,70
M16	2,0	1,5xD	10	389.1600	18,20
M18	2,5	1,5xD	10	389.1801	33,50
M20	2,5	1,5xD	10	389.2000	37,50
M24	3	1,5xD	10	389.2431	42,70

M3	0,5	2xD	25	389.0302	10,75
M4	0,7	2xD	25	389.0402	10,75
M5	0,8	2xD	25	389.0502	12,00
M6	1,0	2xD	25	389.0602	14,00
M7	1,0	2xD	25	389.0702	19,00
M8	1,25	2xD	25	389.0802	16,50
M10	1,5	2xD	25	389.1002	19,50
M12	1,75	2xD	10	389.1202	11,70

d ₁	p	l ₁	St./VE	Art.nr.	€ / VE
M14	2,0	2xD	10	389.1402	18,00
M16	2,0	2xD	10	389.1601	22,40
M18	2,5	2xD	10	389.1802	35,70
M20	2,5	2xD	10	389.2002	48,20
M24	3	2xD	10	389.2432	53,40

M3	0,5	2,5xD	25	389.0303	11,00
M4	0,7	2,5xD	25	389.0403	11,00
M5	0,8	2,5xD	25	389.0504	15,00
M6	1,0	2,5xD	25	389.0604	16,25
M7	1,0	2,5xD	25	389.0703	21,25
M8	1,25	2,5xD	25	389.0804	20,00
M10	1,5	2,5xD	25	389.1004	24,25
M12	1,75	2,5xD	10	389.1203	15,40
M14	2,0	2,5xD	10	389.1403	21,40
M16	2,0	2,5xD	10	389.1603	28,40
M18	2,5	2,5xD	10	389.1803	49,00
M20	2,5	2,5xD	10	389.2004	60,90
M24	3	2,5xD	10	389.2403	81,70

M3	0,5	3xD	25	389.0304	15,00
M4	0,7	3xD	25	389.0404	13,50
M5	0,8	3xD	25	389.0503	17,25
M6	1,0	3xD	25	389.0603	20,50
M7	1,0	3xD	25	389.0704	25,75
M8	1,25	3xD	25	389.0803	23,75
M10	1,5	3xD	25	389.1003	29,75
M12	1,75	3xD	10	389.1204	18,90
M14	2,0	3xD	10	389.1404	25,80
M16	2,0	3xD	10	389.1604	31,00
M18	2,5	3xD	10	389.1804	55,10
M20	2,5	3xD	10	389.2003	69,80
M24	3	3xD	10	389.2404	90,90

Ro-Coil draadinsert, metrisch fijn [MF]

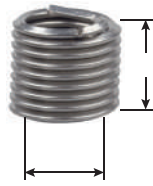

MF

Uitvoering: Ro-Coil draadinsert, vervaardigd uit hoogwaardig RVS, temperatuur- en corrosiebestendig.

Toepassing: Schroefdraadbescherming in de wat zachtere metaalsoorten zoals: aluminium- en magnesium legeringen. Veel toegepast in automobielindustrie, machinebouw, elektro- en medische techniek alsook in de lucht- en ruimtevaartindustrie.

d ₁	p	l ₁	St./VE	Art.nr.	€ / VE
MF8	1,0	1xD	25	389.0810	14,00
MF10	1,25	1xD	25	389.1010	15,50
MF10	1,0	1xD	25	389.1020	15,50
MF12	1,5	1xD	25	389.1210	22,50
MF12	1,25	1xD	25	389.1220	22,50
MF12	1,0	1xD	25	389.1230	26,25
MF14	1,5	1xD	10	389.1450	12,80
MF14	1,25	1xD	10	389.1413	14,70
MF16	1,5	1xD	10	389.1615	16,90
MF8	1,0	1,5xD	25	389.0811	14,00
MF10	1,25	1,5xD	25	389.1011	16,50
MF10	1,0	1,5xD	25	389.1021	16,50
MF12	1,5	1,5xD	25	389.1211	26,25
MF12	1,25	1,5xD	25	389.1221	29,25
MF12	1,0	1,5xD	25	389.1231	26,25
MF14	1,5	1,5xD	10	389.1451	14,70
MF14	1,25	1,5xD	10	389.1414	15,40
MF16	1,5	1,5xD	10	389.1616	19,20
MF8	1,0	2xD	25	389.0812	18,00
MF10	1,25	2xD	25	389.1012	19,50
MF10	1,0	2xD	25	389.1022	19,50
MF12	1,5	2xD	10	389.1212	11,70
MF12	1,25	2xD	10	389.1222	11,70

d ₁	p	l ₁	St./VE	Art.nr.	€ / VE
MF12	1,0	2xD	10	389.1232	13,20
MF14	1,5	2xD	10	389.1452	13,50
MF14	1,25	2xD	10	389.1422	15,90
MF16	1,5	2xD	10	389.1617	21,10
MF8	1,0	2,5xD	25	389.0813	19,50
MF10	1,25	2,5xD	25	389.1013	21,50
MF10	1,0	2,5xD	25	389.1023	21,50
MF12	1,5	2,5xD	10	389.1213	13,60
MF12	1,25	2,5xD	10	389.1223	13,60
MF12	1,0	2,5xD	10	389.1233	13,60
MF14	1,5	2,5xD	10	389.1423	19,00
MF14	1,25	2,5xD	10	389.1433	19,00
MF16	1,5	2,5xD	10	389.1613	25,30
MF8	1,0	3xD	25	389.0814	22,75
MF10	1,25	3xD	25	389.1014	27,50
MF10	1,0	3xD	25	389.1024	27,50
MF12	1,5	3xD	10	389.1214	16,90
MF12	1,25	3xD	10	389.1224	16,90
MF12	1,0	3xD	10	389.1234	16,90
MF14	1,5	3xD	10	389.1424	23,00
MF14	1,25	3xD	10	389.1434	23,00
MF16	1,5	3xD	10	389.1614	27,60

Ro-Coil draadinsert, UNC



UNC

Uitvoering: Ro-Coil draadinsert, vervaardigd uit hoogwaardig RVS, temperatuur- en corrosiebestendig.

Toepassing: Schroefdraadbescherming in de wat zachtere metaalsoorten zoals: aluminium- en magnesium legeringen. Veel toegepast in automobielindustrie, machinebouw, elektro- en medische techniek alsook in de lucht- en ruimtevaartindustrie.

d ₁ (inch)	P	l ₁	St./VE	Art.nr.	€ / VE
No. 10	24	1,5xD	100	389.4035	51,00
1/4	20	1,5xD	100	389.4037	56,00
5/16	18	1,5xD	100	389.4042	80,00

d ₁ (inch)	P	l ₁	St./VE	Art.nr.	€ / VE
3/8	16	1,5xD	100	389.4047	112,00
1/2	13	1,5xD	100	389.4057	160,00
5/8	11	1,5xD	50	389.4067	282,00

Ro-Coil draadinsert, UNF

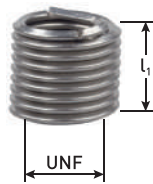

UNF

Uitvoering: Ro-Coil draadinsert, vervaardigd uit hoogwaardig RVS, temperatuur- en corrosiebestendig.

Toepassing: Schroefdraadbescherming in de wat zachtere metaalsoorten zoals: aluminium- en magnesium legeringen. Veel toegepast in automobielindustrie, machinebouw, elektro- en medische techniek alsook in de lucht- en ruimtevaartindustrie.

d ₁ (inch)	P	l ₁	St./VE	Art.nr.	€ / VE
No. 10	32	1,5xD	100	389.5029	51,00
1/4	28	1,5xD	100	389.5030	59,00
5/16	24	1,5xD	100	389.5031	80,00

d ₁ (inch)	P	l ₁	St./VE	Art.nr.	€ / VE
3/8	24	1,5xD	100	389.5032	112,00
1/2	20	1,5xD	100	389.5034	160,00
5/8	18	1,5xD	50	389.5036	168,50

396

Ro-Coil draad-reparatie-set, metrisch, 1.5xD



Inhoud: Ro-Coils (aantal volgens tabel)
1x bijbehorende boor (sets t/m M12)
1x eindsnijder
1x draadinzetter
1x draadlipbreker (sets t/m M12)

Toepassing: Voor het repareren van beschadigd draad. Na toepassing van het Ro-Coil draadreparatiesysteem is een verbinding ontstaan die door de precieze en exacte tolerantie beter en sterker is dan de oorspronkelijke draad. Ro-Coils worden ook toegepast bij een zgn. eerste montage.

d ₁	p	Ro-Coils	St./VE	Art.nr.	€ / VE
M3	0,5	20	1	396.0300	40,52
M4	0,7	20	1	396.0400	33,59
M5	0,8	20	1	396.0500	34,95
M6	1,0	20	1	396.0600	37,68
M7	1,0	20	1	396.0700	57,87
M8	1,25	20	1	396.0800	47,96
M10	1,5	15	1	396.1000	51,23

d ₁	p	Ro-Coils	St./VE	Art.nr.	€ / VE
M12	1,75	10	1	396.1200	57,41
M14	2,0	10	1	396.1400	52,46
M16	2,0	10	1	396.1600	93,85
M18	2,5	5	1	396.1800	111,35
M20	2,5	5	1	396.2000	120,62
M24	3,0	5	1	396.2400	160,19

396

Ro-Coil draad-reparatie-set, metrisch-fijn, 1.5xD



Inhoud: Ro-Coils (aantal volgens tabel)
1x bijbehorende boor (sets t/m M12)
1x eindsnijder
1x draadinzetter
1x draadlipbreker (sets t/m M12)

Toepassing: Voor het repareren van beschadigd draad. Na toepassing van het Ro-Coil draadreparatiesysteem is een verbinding ontstaan die door de precieze en exacte tolerantie beter en sterker is dan de oorspronkelijke draad. Ro-Coils worden ook toegepast bij een zgn. eerste montage.

d ₁	p	Ro-Coils	St./VE	Art.nr.	€ / VE
MF8	1,0	20	1	396.0801	57,87
MF10	1,25	15	1	396.1001	51,23
MF10	1,0	15	1	396.1002	61,80
MF12	1,5	10	1	396.1201	57,41

d ₁	p	Ro-Coils	St./VE	Art.nr.	€ / VE
MF12	1,25	10	1	396.1202	69,27
MF12	1,0	10	1	396.1203	69,27
MF14	1,5	10	1	396.1401	77,54
MF18	1,5	5	1	396.1802	111,35

Ro-Coil draad-reparatie-assortiment, metrisch, 1.5xD



Toepassing: Voor het repareren van beschadigd draad. Na toepassing van het Ro-Coil draadreparatiesysteem is een verbinding ontstaan die door de precieze en exacte tolerantie beter en sterker is dan de oorspronkelijke draad. Ro-Coils worden ook toegepast bij een zgn. eerste montage.

Omschrijving	Inhoud	St./VE	Art.nr.	€ / VE
Draadreparatie assortiment M5 - M12	1x boor ø5,2 - ø6,3 - ø8,3 - ø10,4 en ø12,4 1x eindsnijder M5, M6, M8, M10 en M12 1x draadinzetter Nr. 8, 9, 11, 13 en 15 1x draadlipbreker Nr. 8, 9, 11, 13 en 15 25x Ro-Coil inserts M5, M6, M8 en M10 10x Ro-Coil inserts M12	1	396.9001	228,30

391

Ro-Coil draad-reparatie-set, UNC, 1.5xD

ROTEC®



Uitvoering: Ro-Coils (aantal volgens tabel)
1x bijbehorende boor (sets t/m UNC 1/2x13)
1x eindsnijder
1x draadinzetter
1x draadlipbreker (sets t/m UNC 1/2x13)

Toepassing: Voor het repareren van beschadigd draad. Na toepassing van het Ro-Coil draadreparatiesysteem is een verbinding ontstaan die door de precieze en exacte tolerantie beter en sterker is dan de oorspronkelijke draad. Ro-Coils worden ook toegepast bij een zgn. eerste montage.

d ₁ (inch)	P	Ro-Coils	St./VE	Art.nr.	€ / VE
1/4	20	20	1	391.0014	57,88
5/16	18	20	1	391.0016	70,92
3/8	16	15	1	391.0018	75,67
7/16	14	10	1	391.0020	84,93
1/2	13	10	1	391.0022	93,24

d ₁ (inch)	P	Ro-Coils	St./VE	Art.nr.	€ / VE
9/16	12	10	1	391.0024	124,55
5/8	11	10	1	391.0026	124,55
3/4	10	5	1	391.0028	158,94
7/8	9	5	1	391.0030	193,10
1	8	4	1	391.0032	184,10

392

Ro-Coil draad-reparatie-set, UNF, 1.5xD

ROTEC®



Uitvoering: Ro-Coils (aantal volgens tabel)
1x bijbehorende boor (sets t/m UNF 1/2x20)
1x eindsnijder
1x draadinzetter
1x draadlipbreker (sets t/m UNF 1/2x20)

Toepassing: Voor het repareren van beschadigd draad. Na toepassing van het Ro-Coil draadreparatiesysteem is een verbinding ontstaan die door de precieze en exacte tolerantie beter en sterker is dan de oorspronkelijke draad. Ro-Coils worden ook toegepast bij een zgn. eerste montage.

d ₁ (inch)	P	Ro-Coils	St./VE	Art.nr.	€ / VE
1/4	28	20	1	392.0014	57,88
5/16	24	20	1	392.0016	70,92
3/8	24	15	1	392.0018	75,67
7/16	20	10	1	392.0020	84,93
1/2	20	10	1	392.0022	93,24

d ₁ (inch)	P	Ro-Coils	St./VE	Art.nr.	€ / VE
9/16	18	10	1	392.0024	124,55
5/8	18	10	1	392.0026	124,55
3/4	16	5	1	392.0028	158,94
7/8	14	5	1	392.0030	193,10
1	12	4	1	392.0032	184,10

393

Ro-Coil draad-reparatie-set, BSW, 1.5xD

ROTEC®



Uitvoering: Ro-Coils (aantal volgens tabel)
1x bijbehorende boor (sets t/m BSW 1/2x12)
1x eindsnijder
1x draadinzetter
1x draadlipbreker (sets t/m BSW 1/2x12)

Toepassing: Voor het repareren van beschadigd draad. Na toepassing van het Ro-Coil draadreparatiesysteem is een verbinding ontstaan die door de precieze en exacte tolerantie beter en sterker is dan de oorspronkelijke draad. Ro-Coils worden ook toegepast bij een zgn. eerste montage.

d ₁ (inch)	P	Ro-Coils	St./VE	Art.nr.	€ / VE
1/8	40	20	1	393.0010	64,28
3/16	24	20	1	393.0012	64,28
1/4	20	20	1	393.0014	57,88
5/16	18	20	1	393.0016	70,92
3/8	16	15	1	393.0018	75,67
7/16	14	10	1	393.0020	84,93

d ₁ (inch)	P	Ro-Coils	St./VE	Art.nr.	€ / VE
1/2	12	10	1	393.0022	93,24
9/16	12	10	1	393.0024	124,55
5/8	11	10	1	393.0026	124,55
3/4	10	5	1	393.0028	158,94
7/8	9	5	1	393.0030	193,10
1	8	4	1	393.0032	184,10



Uitvoering: Ro-Coils (aantal volgens tabel)
1x 2-dlg. handtapset
1x draadinzetter

Toepassing: Voor het repareren van beschadigd draad. Na toepassing van het Ro-Coil draadreparatiesysteem is een verbinding ontstaan die door de precieze en exacte tolerantie beter en sterker is dan de oorspronkelijke draad. Ro-Coils worden ook toegepast bij een zgn. eerste montage.

d ₁ (inch)	P	Ro-Coils	St./VE	Art.nr.	€ / VE
1/8	28	10	1	395.0125	161,26
1/4	19	10	1	395.0250	179,24
3/8	19	10	1	395.0375	197,21
1/2	14	10	1	395.0500	249,00

d ₁ (inch)	P	Ro-Coils	St./VE	Art.nr.	€ / VE
5/8	14	10	1	395.0675	548,43
3/4	14	10	1	395.0750	548,43
7/8	14	10	1	395.0875	731,35
1	11	10	1	395.1000	763,87

