

ROTEC[®]



Hole saws
and annular cutters

CUTTING CONDITIONS FOR HSS, HSS-E AND TCT ANNULAR CUTTERS

Material suitability	Steel < 500 N/mm ²	Steel < 750 N/mm ²	Steel < 900 N/mm ²	Steel < 1200 N/mm ²	Steel < 1400 N/mm ²	Alloyed steel (stainless) < 900 N/mm ²	Alloyed steel (stainless) > 900 N/mm ²	Aluminium alloys < 11% Si	Grey cast iron < 250 HB	CuZn-alloys (brittle)	CuZn-alloys (tough)
HSS Silver-Line	●	●	◻			◻		○		○	○
HSS Gold-Line	●	●	○	◻		○	◻	○		○	○
HSS Blue-Line	●	●	●	○	◻	●	○	●	○	●	●
TCT Hard-Line	●	●	●	●	●	●	●	●	●	●	●

● = Optimal / ○ = Good / ◻ = Possible

Cutting conditions for HSS annular cutters (Silver-Line, Gold-Line and Blue-Line) F = feed rate / Vc = cutting speed											
F [mm/rev]	0,15	0,18	0,16	0,16	0,17	0,10	0,10	0,25	0,16	0,18	0,21
Vc [m/min]	30	25	20	15	10	15	10	30	15	40	25
Diameter	RPM	RPM	RPM	RPM	RPM	RPM	RPM	RPM	RPM	RPM	RPM
ø12	790	660	530	390	260	390	260	790	390	1060	660
ø14	680	560	450	340	220	340	220	680	340	900	560
ø16	590	490	390	290	190	290	190	590	290	790	490
ø18	530	440	350	260	170	260	170	530	260	700	440
ø20	470	390	310	230	150	230	150	470	230	630	390
ø22	430	360	280	210	140	210	140	430	210	570	360
ø24	390	330	260	190	130	190	130	390	190	530	330
ø26	360	300	240	180	120	180	120	360	180	480	300
ø28	340	280	220	170	110	170	110	340	170	450	280
ø30	310	260	210	150	100	150	100	310	150	420	260
ø32	290	240	190	140	90	140	90	290	140	390	240
ø34	280	230	180	140	90	140	90	280	140	370	230
ø36	260	220	170	130	80	130	80	260	130	350	220
ø38	250	200	160	120	80	120	80	250	120	330	200
ø40	230	190	150	110	70	110	70	230	110	310	190
ø45	210	170	140	100	70	100	70	210	100	280	170
ø50	190	150	120	90	60	90	60	190	90	250	150
ø55	170	140	110	80	50	80	50	170	80	230	140
ø60	150	130	100	70	50	70	50	150	70	210	130
ø65	140	120	90	70	40	70	40	140	70	190	120

Cutting conditions for TCT annular cutters (Hard-Line) F = feed rate / Vc = cutting speed											
F [mm/rev]	0,10	0,10	0,10-0,12	0,10-0,15	0,16	0,13	0,13	0,24	0,08-0,13	0,12	0,12
Vc [m/min]	50	45	40	35	25	20	15	65	40	50	35
Diameter	RPM	RPM	RPM	RPM	RPM	RPM	RPM	RPM	RPM	RPM	RPM
ø12	1320	1190	1060	920	660	530	390	1720	1060	1320	920
ø14	1130	1020	900	790	560	450	340	1470	900	1130	790
ø16	990	890	790	690	490	390	290	1290	790	990	690
ø18	880	790	700	610	440	350	260	1140	700	880	610
ø20	790	710	630	550	390	310	230	1030	630	790	550
ø22	720	650	570	500	360	280	210	940	570	720	500
ø24	660	590	530	460	330	260	190	860	530	660	460
ø26	610	550	480	420	300	240	180	790	480	610	420
ø28	560	510	450	390	280	220	170	730	450	560	390
ø30	530	470	420	370	260	210	150	680	420	530	370
ø32	490	440	390	340	240	190	140	640	390	490	340
ø34	460	420	370	320	230	180	140	600	370	460	320
ø36	440	390	350	300	220	170	130	570	350	440	300
ø38	410	370	330	290	200	160	120	540	330	410	290
ø40	390	350	310	270	190	150	110	510	310	390	270
ø45	350	310	280	240	170	140	100	450	280	350	240
ø50	310	280	250	220	150	120	90	410	250	310	220
ø55	280	260	230	200	140	110	80	370	230	280	200
ø60	260	230	210	180	130	100	70	340	210	260	180
ø65	240	220	190	170	120	90	70	310	190	240	170

BiM-Co Hole saw, regular pitch (4/6)



Execution: BiM-Co (Bi-metal with 8%Co), teeth milled, side set. Excellent cutting results in [alloyed] steel and stainless steel due to 8% cobalt alloy base material. Robust design with extra firm lid for more stability. 100% Made in Germany!

Application: For sawing holes in most commonly used metals, plastics and woods.

d ₁	d ₁ (inch)	T _{max}	pcs/PU	Item no.	€ / PU
14,0	9/16	38	1	527.0140	10,46
16,0	5/8	38	1	527.0160	10,46
17,0	11/16	38	1	527.0170	10,46
19,0	3/4	38	1	527.0190	10,46
20,0	25/32	38	1	527.0200	10,46
21,0	13/16	38	1	527.0210	10,46
22,0	7/8	38	1	527.0220	10,70
23,0	29/32	38	1	527.0230	10,70
24,0	15/16	38	1	527.0240	10,70
25,0	1	38	1	527.0250	11,15
27,0	1-1/16	38	1	527.0270	11,15
29,0	1-1/8	38	1	527.0290	11,45
30,0	1-3/16	38	1	527.0300	11,45
32,0	1-1/4	38	1	527.0320	11,45
33,0	1-5/16	38	1	527.0330	11,45
35,0	1-3/8	38	1	527.0350	11,95
37,0	1-7/16	38	1	527.0370	11,95
38,0	1-1/2	38	1	527.0380	11,95
40,0	1-9/16	38	1	527.0400	12,91
41,0	1-5/8	38	1	527.0410	12,91
43,0	1-11/16	38	1	527.0430	12,91
44,0	1-3/4	38	1	527.0440	14,56
46,0	1-13/16	38	1	527.0460	14,56
48,0	1-7/8	38	1	527.0480	14,56
51,0	2	38	1	527.0510	14,56
52,0	2-1/16	38	1	527.0520	18,21
54,0	2-1/8	38	1	527.0540	18,21
57,0	2-1/4	38	1	527.0570	18,21
58,0	2-9/32	38	1	527.0580	18,21
59,0	2-5/16	38	1	527.0590	18,21
60,0	2-3/8	38	1	527.0600	18,21

d ₁	d ₁ (inch)	T _{max}	pcs/PU	Item no.	€ / PU
64,0	2-1/2	38	1	527.0640	19,79
65,0	2-9/16	38	1	527.0650	19,79
67,0	2-5/8	38	1	527.0670	19,79
68,0	2-11/16	38	1	527.0680	19,79
70,0	2-3/4	38	1	527.0700	19,79
73,0	2-7/8	38	1	527.0730	19,79
74,0	2-29/32	38	1	527.0740	21,35
76,0	3	38	1	527.0760	20,30
79,0	3-1/8	38	1	527.0790	20,30
83,0	3-1/4	38	1	527.0830	21,61
86,0	3-3/8	38	1	527.0860	22,81
89,0	3-1/2	38	1	527.0890	23,03
92,0	3-5/8	38	1	527.0920	23,65
95,0	3-3/4	38	1	527.0950	25,03
98,0	3-7/8	38	1	527.0980	28,77
102,0	4	38	1	527.1020	28,77
105,0	4-1/8	38	1	527.1050	32,24
108,0	4-1/4	38	1	527.1080	41,46
111,0	4-3/8	38	1	527.1110	47,02
114,0	4-1/2	38	1	527.1140	58,07
121,0	4-3/4	38	1	527.1210	63,85
127,0	5	38	1	527.1270	70,62
133,0	5-1/4	38	1	527.1330	82,86
140,0	5-1/2	38	1	527.1400	83,86
146,0	5-3/4	38	1	527.1460	92,02
152,0	6	38	1	527.1520	97,06
160,0	6-5/16	38	1	527.1600	152,67
168,0	6-5/8	38	1	527.1680	161,45
177,0	7	38	1	527.1770	168,44
200,0	7-7/8	38	1	527.2000	182,15
210,0	8-1/4	38	1	527.2100	196,44

BiM-Co Hole saw, fine pitch (8/12)

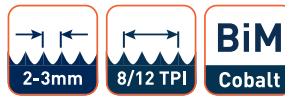

Execution: BiM-Co (Bi-metal with 8%Co), teeth milled, side set, fine variable pitch [8/12 TPI]. Fine pitched hole saws are preferred on thinner material. Robust design with extra firm lid for more stability. 100% Made in Germany!

Application: For sawing holes in most commonly used metals, plastics and woods. For thin sheet metals (<2mm) [stainless steel <1mm].

d ₁	d ₁ (inch)	T _{max}	pcs/PU	Item no.	€ / PU
14,0	9/16	38	1	530.5140	16,53
16,0	5/8	38	1	530.5160	13,52
17,0	11/16	38	1	530.5170	16,53
19,0	3/4	38	1	530.5190	13,52
20,0	25/32	38	1	530.5200	13,52
21,0	13/16	38	1	530.5210	18,01
22,0	7/8	38	1	530.5220	13,97
23,0	29/32	38	1	530.5230	18,01
24,0	15/16	38	1	530.5240	15,45
25,0	1	38	1	530.5250	14,49
27,0	1-1/16	38	1	530.5270	17,34
29,0	1-1/8	38	1	530.5290	15,00
30,0	1-3/16	38	1	530.5300	17,34
32,0	1-1/4	38	1	530.5320	15,73
35,0	1-3/8	38	1	530.5350	17,67
38,0	1-1/2	38	1	530.5380	18,10
40,0	1-9/16	38	1	530.5400	19,13
41,0	1-5/8	38	1	530.5410	19,13
43,0	1-11/16	38	1	530.5430	22,08
44,0	1-3/4	38	1	530.5440	20,04
46,0	1-13/16	38	1	530.5460	20,53

d ₁	d ₁ (inch)	T _{max}	pcs/PU	Item no.	€ / PU
48,0	1-7/8	38	1	530.5480	21,44
51,0	2	38	1	530.5510	20,04
54,0	2-1/8	38	1	530.5540	24,56
57,0	2-1/4	38	1	530.5570	25,87
60,0	2-3/8	38	1	530.5600	27,32
64,0	2-1/2	38	1	530.5640	30,12
65,0	2-9/16	38	1	530.5650	30,38
68,0	2-11/16	38	1	530.5680	31,67
70,0	2-3/4	38	1	530.5700	32,39
73,0	2-7/8	38	1	530.5730	33,40
76,0	3	38	1	530.5760	34,00
83,0	3-1/4	38	1	530.5830	35,65
86,0	3-3/8	38	1	530.5860	36,96
89,0	3-1/2	38	1	530.5890	37,92
92,0	3-5/8	38	1	530.5920	39,54
98,0	3-7/8	38	1	530.5980	42,52
105,0	4-1/8	38	1	530.6105	54,26
108,0	4-1/4	38	1	530.6108	51,72
114,0	4-1/2	38	1	530.6114	55,65
127,0	5	38	1	530.6127	65,89

BiM-Co hole saw set (4/6) with Quick-Lock



Description	Type	Content	pcs/PU	Item no.	€ / PU
10 pc Hole saw set (527) 'Plumber' HSS-BiMCo8, hexagon shank 9 mm	527	1x ϕ 19, 22, 27, 32, 35, 40, 51 and 64mm 1x Quick-Lock adapter 14-30mm (HEX 9) 1x Quick-Lock adapter 32-210mm (HEX 9)	1	527.4105	147,02
10 pc Hole saw set (527) 'Electrician' HSS-BiMCo8, hexagon shank 9 mm	527	1x ϕ 22, 27, 35, 38, 44, 51, 68 and 76mm 1x Quick-Lock adapter 14-30mm (HEX 9) 1x Quick-Lock adapter 32-210mm (HEX 9)	1	527.4110	163,50
14 pc Hole saw set (527) 'Allround' HSS-BiMCo8, hexagon shank 9 mm	527	1x ϕ 19, 22, 25, 32, 35, 38, 44, 51, 57, 64, 68 and 76mm 1x Quick-Lock adapter 14-30mm (HEX 9) 1x Quick-Lock adapter 32-210mm (HEX 9)	1	527.4125	245,82

BiM-Co hole saw set (4/6) with Fast-Change



Description	Type	Content	pcs/PU	Item no.	€ / PU
13 pc Hole saw set (527) 'Electrician' HSS-BiMCo8, hexagon shank 11 mm	527	1x ϕ 22, 27, 32, 35, 38, 44, 51, 60, 68 and 76mm 1x Fast-Change holder (HEX 11) 2x HSS Pilot drill	1	527.7105	247,96
13 pc Hole saw set (527) 'Electrician' HSS-BiMCo8, shank SDS+	527	1x ϕ 22, 27, 32, 35, 38, 44, 51, 60, 68 and 76mm 1x Fast-Change holder (SDS+) 2x HSS Pilot drill	1	527.7205	252,61
16 pc Hole saw set (527) 'Allround' HSS-BiMCo8, hexagon shank 11 mm	527	1x ϕ 19, 22, 25, 32, 35, 38, 44, 51, 57, 60, 64, 68 and 76mm 1x Fast-Change holder (HEX 11) 2x HSS Pilot drill	1	527.7110	298,29
16 pc Hole saw set (527) 'Allround' HSS-BiMCo8, shank SDS+	527	1x ϕ 19, 22, 25, 32, 35, 38, 44, 51, 57, 60, 64, 68 and 76mm 1x Fast-Change holder (SDS+) 2x HSS Pilot drill	1	527.7210	302,93
19 pc Hole saw set (527) 'MAX' HSS-BiMCo8, hexagon shank 11 mm	527	1x ϕ 19, 22, 25, 29, 32, 35, 38, 44, 51, 57, 60, 64, 68, 76, 83 and 92mm 1x Fast-Change holder (HEX 11) 2x HSS Pilot drill	1	527.7115	356,40
19 pc Hole saw set (527) 'MAX' HSS-BiMCo8, shank SDS+	527	1x ϕ 19, 22, 25, 29, 32, 35, 38, 44, 51, 57, 60, 64, 68, 76, 83 and 92mm 1x Fast-Change holder (SDS+) 2x HSS Pilot drill	1	527.7215	361,04

533

BiM-Co Hole saw, regular pitch (4/6)

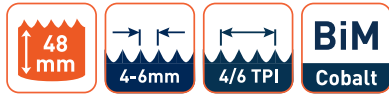

Execution: BiM-Co [Bi-metal with 8%Co], teeth milled, side set. Excellent cutting results in [alloyed] steel and stainless steel due to 8% cobalt alloy base material. Robust design with extra firm lid for more stability. 100% Made in Germany!

Application: For sawing holes in most commonly used metals, plastics and woods.
Material groups: 1.1-1.5 / 1.6 / 2.1 - 2.2 / 2.3 / 3.1 - 3.3 / 4.1 - 4.12

d ₁	d ₁ (inch)	T _{max}	pcs/PU	Item no.	€ / PU
14,0	9/16	48	1	533.0014	11,49
16,0	5/8	48	1	533.0016	11,49
17,0	11/16	48	1	533.0017	11,49
19,0	3/4	48	1	533.0019	11,49
20,0	25/32	48	1	533.0020	11,49
21,0	13/16	48	1	533.0021	11,49
22,0	7/8	48	1	533.0022	11,75
24,0	15/16	48	1	533.0024	11,75
25,0	1	48	1	533.0025	12,25
27,0	1-1/16	48	1	533.0027	12,25
29,0	1-1/8	48	1	533.0029	12,56
30,0	1-3/16	48	1	533.0030	12,56
32,0	1-1/4	48	1	533.0032	12,56
33,0	1-5/16	48	1	533.0033	12,56
35,0	1-3/8	48	1	533.0035	13,13
37,0	1-7/16	48	1	533.0037	13,13
38,0	1-1/2	48	1	533.0038	13,13
40,0	1-9/16	48	1	533.0040	13,13
41,0	1-5/8	48	1	533.0041	13,13
43,0	1-11/16	48	1	533.0043	13,13
44,0	1-3/4	48	1	533.0044	15,98
45,0	1-25/32	48	1	533.0045	15,98
46,0	1-13/16	48	1	533.0046	15,98
48,0	1-7/8	48	1	533.0048	15,98
50,0	1-31/32	48	1	533.0050	15,98
51,0	2	48	1	533.0051	15,98
52,0	2-1/16	48	1	533.0052	20,01
54,0	2-1/8	48	1	533.0054	20,01
55,0	2-5/32	48	1	533.0055	20,01
57,0	2-1/4	48	1	533.0057	20,01
59,0	2-5/16	48	1	533.0059	20,01
60,0	2-3/8	48	1	533.0060	20,01

d ₁	d ₁ (inch)	T _{max}	pcs/PU	Item no.	€ / PU
64,0	2-1/2	48	1	533.0064	21,74
65,0	2-9/16	48	1	533.0065	21,74
67,0	2-5/8	48	1	533.0067	21,74
68,0	2-11/16	48	1	533.0068	21,74
70,0	2-3/4	48	1	533.0070	21,74
73,0	2-7/8	48	1	533.0073	21,74
75,0	2-15/16	48	1	533.0075	22,32
76,0	3	48	1	533.0076	22,32
79,0	3-1/8	48	1	533.0079	22,32
83,0	3-1/4	48	1	533.0083	23,74
86,0	3-3/8	48	1	533.0086	25,05
89,0	3-1/2	48	1	533.0089	25,31
92,0	3-5/8	48	1	533.0092	26,00
95,0	3-3/4	48	1	533.0095	27,49
98,0	3-7/8	48	1	533.0098	31,63
100,0	3-15/16	48	1	533.0100	31,63
102,0	4	48	1	533.0102	31,63
105,0	4-1/8	48	1	533.0105	35,43
108,0	4-1/4	48	1	533.0108	45,56
111,0	4-3/8	48	1	533.0111	51,68
114,0	4-1/2	48	1	533.0114	63,81
121,0	4-3/4	48	1	533.0121	70,16
127,0	5	48	1	533.0127	77,61
133,0	5-1/4	48	1	533.0133	91,04
140,0	5-1/2	48	1	533.0140	92,16
146,0	5-3/4	48	1	533.0146	101,11
152,0	6	48	1	533.0152	106,64
160,0	6-5/16	48	1	533.0160	152,51
168,0	6-5/8	48	1	533.0168	161,26
177,0	7	48	1	533.0177	168,24
200,0	7-7/8	48	1	533.0200	181,94
210,0	8-1/4	48	1	533.0210	196,22

BiM-Co hole saw set (4/6) with Quick-Lock



Description	Type	Content	pcs/PU	Item no.	€ / PU
10 pc Hole saw set (533) 'Plumber' HSS-BiMCo8, hexagon shank 9 mm	533	1x ø19, 22, 27, 32, 35, 40, 51 and 64mm 1x Quick-Lock adapter 14-30mm (HEX 9) 1x Quick-Lock adapter 32-210mm (HEX 9)	1	533.9505	159,64
10 pc Hole saw set (533) 'Electrician' HSS-BiMCo8, hexagon shank 9 mm	533	1x ø22, 27, 35, 38, 44, 51, 68 and 76mm 1x Quick-Lock adapter 14-30mm (HEX 9) 1x Quick-Lock adapter 32-210mm (HEX 9)	1	533.9510	177,51
14 pc Hole saw set (533) 'Allround' HSS-BiMCo8, hexagon shank 9 mm	533	1x ø19, 22, 25, 32, 35, 38, 44, 51, 57, 64, 68 and 76mm 1x Quick-Lock adapter 14-30mm (HEX 9) 1x Quick-Lock adapter 32-210mm (HEX 9)	1	533.9515	266,90

BiM-Co hole saw set (4/6) with Fast-Change



Description	Type	Content	pcs/PU	Item no.	€ / PU
13 pc Hole saw set (533) 'Electrician' HSS-BiMCo8, hexagon shank 11 mm	533	1x ø22, 27, 32, 35, 38, 44, 51, 60, 68 and 76mm 1x Fast-Change holder (HEX 11) 2x HSS Pilot drill	1	533.9705	260,99
16 pc Hole saw set (533) 'Allround' HSS-BiMCo8, hexagon shank 11 mm	533	1x ø19, 22, 25, 32, 35, 38, 44, 51, 57, 60, 64, 68 and 76mm 1x Fast-Change holder (HEX 11) 2x HSS Pilot drill	1	533.9710	300,04
19 pc Hole saw set (533) 'MAX' HSS-BiMCo8, hexagon shank 11 mm	533	1x ø19, 22, 25, 29, 32, 35, 38, 44, 51, 57, 60, 64, 68, 76, 83 and 92mm 1x Fast-Change holder (HEX 11) 2x HSS Pilot drill	1	533.9715	353,77



Execution: High-performance, all-round hole saw with individually ground carbide teeth suitable for the toughest jobs. Includes 'Fast-Change' adapter.

Application: Problem-free sawing in steel, stainless steel, cast iron, brass, bronze, aluminum, (hard) wood, brick, tiles, plastics and fibre-reinforced plastics.

Remark: Aufgrund des montierten und nicht abnehmbaren Adapters kann diese Lochsäge nur in Verbindung mit dem Lochsägenhaltersystem 'Fast-Change' verwendet werden.

d ₁	d ₁ (inch)	T _{max}	pcs/PU	Item no.	€ / PU
20,0	25/32	60	1	531.2020	29,90
22,0	7/8	60	1	531.2022	31,03
25,0	1	60	1	531.2025	32,17
32,0	1-1/4	60	1	531.2032	34,06
35,0	1-3/8	60	1	531.2035	35,00
38,0	1-1/2	60	1	531.2038	36,32
40,0	1-9/16	60	1	531.2040	36,89
44,0	1-3/4	60	1	531.2044	37,87
51,0	2	60	1	531.2051	40,89
54,0	2-1/8	60	1	531.2054	49,97

d ₁	d ₁ (inch)	T _{max}	pcs/PU	Item no.	€ / PU
60,0	2-3/8	60	1	531.2060	52,23
64,0	2-1/2	60	1	531.2064	53,37
67,0	2-5/8	60	1	531.2067	54,88
68,0	2-11/16	60	1	531.2068	56,77
70,0	2-3/4	60	1	531.2070	58,28
73,0	2-7/8	60	1	531.2073	59,42
76,0	3	60	1	531.2076	60,55
83,0	3-1/4	60	1	531.2083	62,44
102,0	4	60	1	531.2102	89,73
127,0	5	60	1	531.2127	185,36



Execution: Stable built hole saw with carbide tipped teeth, cuts up to 5 times faster than traditional hole saws. Maximum cutting depth up to 57mm.

Application: For effortless hole making applications in all kinds of softwood, hardwood, particle boards, MDF, [fibre reinforced] plastics like PVC, nylon and epoxy, aerated concrete, bricks, soft stones and tiles (max. core hardness of 6).

d ₁	d ₁ (inch)	T _{max}	pcs/PU	Item no.	€ / PU
14,0 *	9/16	57	1	528.0140	10,00
16,0	5/8	57	1	528.0160	10,00
17,0 *	11/16	57	1	528.0170	10,00
19,0	3/4	57	1	528.0190	10,00
20,0	25/32	57	1	528.0200	10,00
21,0 *	13/16	57	1	528.0210	10,00
22,0	7/8	57	1	528.0220	10,00
24,0	15/16	57	1	528.0240	10,00
25,0	1	57	1	528.0250	10,00
27,0	1-1/16	57	1	528.0270	10,65
29,0	1-1/8	57	1	528.0290	10,65
30,0	1-3/16	57	1	528.0300	10,65
32,0	1-1/4	57	1	528.0320	10,65
33,0 *	1-5/16	57	1	528.0330	11,67
35,0	1-3/8	57	1	528.0350	11,67
37,0 *	1-7/16	57	1	528.0370	11,67
38,0	1-1/2	57	1	528.0380	11,67
40,0	1-9/16	57	1	528.0400	12,87
41,0	1-5/8	57	1	528.0410	14,35
43,0	1-11/16	57	1	528.0430	14,35
44,0	1-3/4	57	1	528.0440	14,35
51,0	2	57	1	528.0510	14,63
52,0	2-1/16	57	1	528.0520	14,63
54,0	2-1/8	57	1	528.0540	17,40
57,0	2-1/4	57	1	528.0570	17,50
60,0	2-3/8	57	1	528.0600	17,50
64,0	2-1/2	57	1	528.0640	19,16
65,0	2-9/16	57	1	528.0650	19,16
67,0	2-5/8	57	1	528.0670	19,25

d ₁	d ₁ (inch)	T _{max}	pcs/PU	Item no.	€ / PU
68,0	2-11/16	57	1	528.0680	19,25
70,0	2-3/4	57	1	528.0700	19,25
73,0	2-7/8	57	1	528.0730	19,25
76,0	3	57	1	528.0760	21,29
79,0	3-1/8	57	1	528.0790	21,29
80,0	3-5/32	57	1	528.0800	21,29
82,0	3-7/32	57	1	528.0820	21,29
83,0	3-1/4	57	1	528.0830	21,76
86,0	3-3/8	57	1	528.0860	24,99
89,0	3-1/2	57	1	528.0890	24,99
92,0	3-5/8	57	1	528.0920	24,99
95,0	3-3/4	57	1	528.0950	26,94
98,0	3-7/8	57	1	528.0980	28,79
102,0	4	57	1	528.1020	29,99
105,0	4-1/8	57	1	528.1050	31,02
108,0	4-1/4	57	1	528.1080	39,53
111,0	4-3/8	57	1	528.1110	43,61
114,0	4-1/2	57	1	528.1140	49,90
121,0	4-3/4	57	1	528.1210	50,91
125,0	4-15/16	57	1	528.1250	58,04
127,0	5	57	1	528.1270	61,01
133,0	5-1/4	57	1	528.1330	69,25
140,0	5-1/2	57	1	528.1400	72,68
152,0	6	57	1	528.1520	77,21
160,0	6-5/16	57	1	528.1600	88,88
165,0	6-1/2	57	1	528.1650	88,88
168,0	6-5/8	57	1	528.1680	94,71
178,0	7	57	1	528.1780	104,80
200,0	7-7/8	57	1	528.2000	127,85

* Phase-out item, available until stock has depleted

TCT Multi-Purpose Hole saw set with Quick-Lock



Description	Type	Content	pcs/PU	Item no.	€ / PU
10 pc Hole saw set [528] ' Plumber ' Carbide tipped (TCT), hexagon shank 9 mm	528	1x ø19, 22, 27, 32, 35, 40, 51 and 64 1x Quick-Lock holder ø14-30 (HEX 9) 1x Quick-Lock holder ø32-210 (HEX 9)	1	528.4001	140,06
10 pc Hole saw set [528] ' Electrician ' Carbide tipped (TCT), hexagon shank 9 mm	528	1x ø22, 27, 35, 38, 44, 51, 68 and 76 1x Quick-Lock holder ø14-30 (HEX 9) 1x Quick-Lock holder ø32-210 (HEX 9)	1	528.4005	161,14
14 pc Hole saw set [528] ' Allround ' Carbide tipped (TCT), hexagon shank 9 mm	528	1x ø19, 22, 25, 32, 35, 38, 44, 51, 57, 64, 68 and 76 1x Quick-Lock holder ø14-30 (HEX 9) 1x Quick-Lock holder ø32-210 (HEX 9)	1	528.4006	215,22

TCT Multi-Purpose Hole saw set with Fast-Change



Description	Type	Content	pcs/PU	Item no.	€ / PU
13 pc Hole saw set [528] ' Electrician ' Carbide tipped (TCT), hexagon shank 11 mm	528	1x ø22, 27, 32, 35, 38, 44, 51, 60, 68 and 76mm 1x Fast-Change holder (HEX 11) 2x Pilot drill bit (1x HSS / 1x TCT)	1	528.5105	245,56
13 pc Hole saw set [528] ' Electrician ' Carbide tipped (TCT), shank SDS+	528	1x ø22, 27, 32, 35, 38, 44, 51, 60, 68 and 76mm 1x Fast-Change holder (SDS+) 2x Pilot drill bit (1x HSS / 1x TCT)	1	528.5205	271,96
16 pc Hole saw set [528] ' Allround ' Carbide tipped (TCT), hexagon shank 11 mm	528	1x ø19, 22, 25, 32, 35, 38, 44, 51, 57, 60, 64, 68 and 76mm 1x Fast-Change holder (HEX 11) 2x Pilot drill bit (1x HSS / 1x TCT)	1	528.5110	284,21
16 pc Hole saw set [528] ' Allround ' Carbide tipped (TCT), shank SDS+	528	1x ø19, 22, 25, 32, 35, 38, 44, 51, 57, 60, 64, 68 and 76mm 1x Fast-Change holder (SDS+) 2x Pilot drill bit (1x HSS / 1x TCT)	1	528.5210	289,61
19 pc Hole saw set [528] ' MAX ' Carbide tipped (TCT), hexagon shank 11 mm	528	1x ø19, 22, 25, 29, 32, 35, 38, 44, 51, 57, 60, 64, 68, 76, 83 and 92mm 1x Fast-Change holder (HEX 11) 2x Pilot drill bit (1x HSS / 1x TCT)	1	528.5115	331,51
19 pc Hole saw set [528] ' MAX ' Carbide tipped (TCT), shank SDS+	528	1x ø19, 22, 25, 29, 32, 35, 38, 44, 51, 57, 60, 64, 68, 76, 83 and 92mm 1x Fast-Change holder (SDS+) 2x Pilot drill bit (1x HSS / 1x TCT)	1	528.5215	336,91

Quick-Lock		Hole saw holders with Quick-Lock system				
Image	Note	Material	Drive	Item no.	pcs/PU	€/PU
	Incl. HSS with pilot drill bit		hex 9	527.3020	1	14,56
	Incl. HSS with pilot drill bit		hex 9	527.3021	1	21,08
	Incl. HSS with pilot drill bit		SDS+	527.3030	1	16,86
	Incl. HSS with pilot drill bit		SDS+	527.3031	1	21,93
	ø6,35x80	HSS	ø6,35	527.3023	1	4,06
	Incl. HSS with pilot drill bit		hex 9	527.3019	1	14,95
	Incl. HSS with pilot drill bit		hex 9	527.3022	1	22,19
	ø6,35x110	HSS	ø6,35	527.3024	1	4,44
	ø7x110	HM	ø6,35	527.3025	1	4,44

Classic		Hole saw holders				
Image	Note	Material	Drive	Item no.	pcs/PU	€/PU
	Incl. HSS with pilot drill bit		hex 1/4"	527.3035	1	8,95
	Incl. HSS with pilot drill bit		hex 9	527.3036	1	8,95
	Incl. HSS with pilot drill bit		hex 9	527.3037	1	22,44
	Incl. HSS with pilot drill bit		hex 11	527.3038	1	22,44
	ø6,35x80	HSS	ø6,35	527.3039	1	3,94
	Incl. HSS with pilot drill bit		hex 9,5	533.9005	1	9,23
	Incl. HSS with pilot drill bit		hex 9,5	533.9010	1	23,16
	Incl. HSS with pilot drill bit		hex 11	533.9015	1	23,16
	ø6,35x83	HSS	ø6,35	533.9100	1	4,35
	ø6,35x102	HSS	ø6,35	533.9105	1	4,59

Fast-Change		Hole saw holders with unique Fast-Lock system, very stabel construction				
Image	Note	Material	Drive	Item no.	pcs/PU	€/PU
	Length: 75mm		hex 8,7	532.0100	1	26,44
	Length: 75mm		hex 11	532.0101	1	29,00
	Length: 150mm		hex 11	532.0102	1	39,16
	Length: 300mm		hex 11	532.0103	1	45,16
	Length: 105mm		SDS+	532.0104	1	33,32
	Fast-Change adapter		1/2"-20 UNF	532.0301 / 532.0302	5 / 10	15,88 / 29,88
	Fast-Change adapter		5/8"-18 UNF	532.0306 / 532.0307	5 / 10	15,88 / 29,88
	ø7,1x85	HSS-G	ø7,1	532.0200	1	9,79
	ø7,1x85	HSS-Co	ø7,1	532.0201	1	12,71
	ø7,1x105	HSS-G	ø7,1	532.0250	1	12,11
	ø7,1x105	HSS-Co	ø7,1	532.0251	1	18,11
	ø8,5x105	HM	ø8,5	532.0252	1	15,67



527

530

533

531

528

ø14 - 210

ø14 - 127

ø14 - 210

ø14 - 127

ø14 - 200

ø14 - 30

ø14 - 30

ø32 - 210

ø32 - 127

ø14 - 30

ø14 - 30

ø32 - 210

ø32 - 127



ø14 - 30

ø14 - 30

ø32 - 210

ø32 - 200



527

530

533

531

528

ø14 - 210

ø14 - 127

ø14 - 210

ø14 - 127

ø14 - 200

ø14 - 30

ø14 - 30

ø32 - 210

ø32 - 127

ø14 - 30

ø14 - 30

ø32 - 210

ø32 - 127



ø14 - 30

ø32 - 210

ø32 - 210



527

530

533

531

528

ø14 - 210

ø14 - 127

ø14 - 210

ø14 - 127

ø14 - 200

Fast-Change adapter

Fast-Change adapter

Fast-Change adapter

Fast-Change adapter

Fast-Change adapter

Fast-Change adapter

Fast-Change adapter

Fast-Change adapter

Fast-Change adapter

Fast-Change adapter

Fast-Change adapter

Fast-Change adapter

Fast-Change adapter

Fast-Change adapter

Fast-Change adapter

Fast-Change adapter

Fast-Change adapter

Fast-Change adapter

Fast-Change adapter

Fast-Change adapter

Fast-Change adapter

Fast-Change adapter

Fast-Change adapter

Fast-Change adapter

Fast-Change adapter

ø14 - 30

ø14 - 30

ø14 - 30

ø20 - 30

ø14 - 30

ø32 - 210

ø32 - 127

ø32 - 210

ø32 - 127

ø32 - 200



527 Enlarging-adapter for hole saws

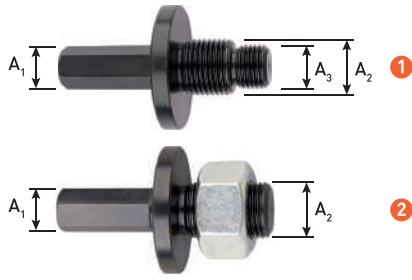

Execution: Adapter for mounting 2 hole saws with different diameters.

Application: For enlarging existing holes to a larger diameter.

1/2"x20 UNF : hole saws ø14-30 mm
5/8"x18 UNF : hole saws ø32-210 mm

Nr.	Description	A ₁	A ₂	A ₃	pcs/PU	Item no.	€ / PU
1	Smallest hole saw (diameter of existing hole) between ø14 and 30 mm serves to centre.	hex. 11	5/8"x18 UNF	1/2"x20 UNF	1	527.3026	26,08
2	Smallest hole saw (diameter of existing hole) from ø32 mm serves to centre.	hex. 11	5/8"x18 UNF		1	527.3027	26,08

Extension for hole saw holders



A ₁	A ₂	l ₁	pcs/PU	Item no.	€ / PU
HEX 9	HEX 11	300	1	527.3040	19,12
HEX 9,5	HEX 11	300	1	527.3041	19,12
HEX 11	HEX 11	300	1	527.3042	19,12

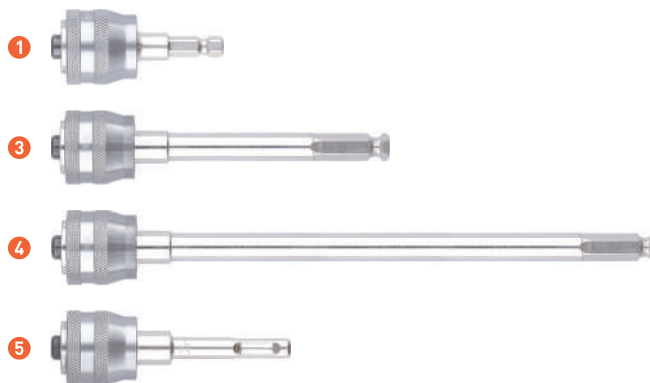
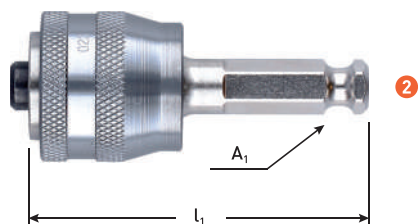

Nr.	Suitable for	A ₁	l ₁	Content	pcs/PU	Item no.	€/PU
1	527 / 528 / 531 / 533	HEX 8,7	75	1x Fast-Change hole saw holder 75 mm, hex. 8,7 mm	1	532.0100	26,44
2	527 / 528 / 531 / 533	HEX 11	75	1x Fast-Change hole saw holder 75 mm, hex. 11 mm	1	532.0101	29,00
3	527 / 528 / 531 / 533	HEX 11	150	1x Fast-Change hole saw holder 150 mm, hex. 11 mm	1	532.0102	39,16
4	527 / 528 / 531 / 533	HEX 11	300	1x Fast-Change hole saw holder 300 mm, hex. 11 mm	1	532.0103	45,16
5	527 / 528 / 531 / 533	SDS-plus	105	1x Fast-Change hole saw holder 105 mm, SDS-plus	1	532.0104	33,32

Fast-Change pilot drill bit



Nr.	Suitable for	Material	Dimensions (mm)	Application	pcs/PU	Item no.	€/PU
1	527	HSS-G	ø7,1 x 85	For Fast-Change hole saw holders type '532.01xx' in combination with bi-metal hole saws type '527'	1	532.0200	9,79
2	527	HSS-Co	ø7,1 x 85	For Fast-Change hole saw holders type '532.01xx' in combination with bi-metal hole saws type '527'	1	532.0201	12,71
3	528 / 531 / 533	HSS-G	ø7,1 x 105	For Fast-Change hole saw holders type '532.01xx' in combination with bi-metal hole saws type '528' or '533'	1	532.0250	12,11
4	528 / 531	TCT	ø8,5 x 105	For Fast-Change hole saw holders type '532.01xx' in combination with bi-metal hole saws type '528'	1	532.0252	15,67

Fast-Change adapter



d (min-max)	F ₂	pcs/PU	Item no.	€ / PU
ø14-30	1/2"-20 UNF	5	532.0301	15,88
ø14-30	1/2"-20 UNF	10	532.0302	29,88
ø32-210	5/8"-18 UNF	5	532.0306	15,88
ø32-210	5/8"-18 UNF	10	532.0307	29,88

Fast-Change starter-kit

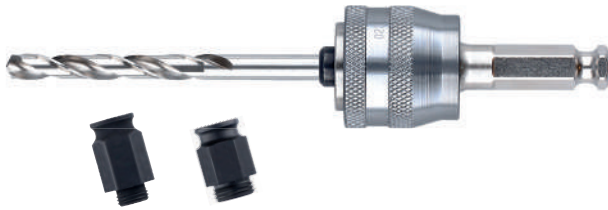

Nr.	Suitable for	Pilot drill bit	Shank	Content	pcs/PU	Item no.	€ / PU
1	527	HSS-G	Hex. 8,7	1x Fast-Change hole saw holder hex. 8,7 mm 1x Fast-Change pilot drill bit HSS-G 85 mm 1x Fast-Change adapter 1/2"-20 UNF (ø14-30 mm) 1x Fast-Change adapter 5/8"-18 UNF (ø32-210 mm)	1	532.0500	41,44
2	527	HSS-G	Hex. 11	1x Fast-Change hole saw holder hex. 11 mm 1x Fast-Change pilot drill bit HSS-G 85 mm 1x Fast-Change adapter 1/2"-20 UNF (ø14-30 mm) 1x Fast-Change adapter 5/8"-18 UNF (ø32-210 mm)	1	532.0501	44,00
3	528 / 533	HSS-G	SDS-plus	1x Fast-Change hole saw holder SDS-plus 1x Fast-Change pilot drill bit HSS-G 85 mm 1x Fast-Change adapter 1/2"-20 UNF (ø14-30 mm) 1x Fast-Change adapter 5/8"-18 UNF (ø32-210 mm)	1	532.0502	48,32
4	528 / 533	HSS-G	Hex. 8,7	1x Fast-Change hole saw holder hex. 8,7 mm 1x Fast-Change pilot drill bit HSS-G 105 mm 1x Fast-Change adapter 1/2"-20 UNF (ø14-30 mm) 1x Fast-Change adapter 5/8"-18 UNF (ø32-210 mm)	1	532.0550	43,76
5	528 / 533	HSS-G	Hex. 11	1x Fast-Change hole saw holder hex. 11 mm 1x Fast-Change pilot drill bit HSS-G 105 mm 1x Fast-Change adapter 1/2"-20 UNF (ø14-30 mm) 1x Fast-Change adapter 5/8"-18 UNF (ø32-210 mm)	1	532.0551	46,32
6	528	HSS-G	SDS-plus	1x Fast-Change hole saw holder SDS-plus 1x Fast-Change pilot drill bit HSS-G 105 mm 1x Fast-Change adapter 1/2"-20 UNF (ø14-30 mm) 1x Fast-Change adapter 5/8"-18 UNF (ø32-210 mm)	1	532.0552	51,80
7	528	TCT	Hex. 8,7	1x Fast-Change hole saw holder hex. 8,7 mm 1x Fast-Change pilot drill bit TCT 105 mm 1x Fast-Change adapter 1/2"-20 UNF (ø14-30 mm) 1x Fast-Change adapter 5/8"-18 UNF (ø32-210 mm)	1	532.0553	47,32
8	528	TCT	Hex. 11	1x Fast-Change hole saw holder hex. 8,7 mm 1x Fast-Change pilot drill bit TCT 105 mm 1x Fast-Change adapter 1/2"-20 UNF (ø14-30 mm) 1x Fast-Change adapter 5/8"-18 UNF (ø32-210 mm)	1	532.0554	49,88
9	528	TCT	SDS-plus	1x Fast-Change hole saw holder SDS-plus 1x Fast-Change pilot drill bit TCT 105 mm 1x Fast-Change adapter 1/2"-20 UNF (ø14-30 mm) 1x Fast-Change adapter 5/8"-18 UNF (ø32-210 mm)	1	532.0555	55,36

529

BiM-Co Roofers' pipe hole saw, 300mm (4/6)



Execution: BiM-Co (Bi-metal with 8% Co alloy), roofers' pipe hole saw with variable pitch (4/6 TPI) and 1/2"-14 BSP(G) connection. Supplied with hexagon shank adapter (779.0050) and pilot auger bit (240.2001S). Can also be used with HSS twisted drill bit (160.1203) as pilot drill (sold separately).

Application: For sawing fast and precise holes (for exhaust pipes of heating systems or waste air pipes in sanitary systems) in most commonly used materials. Not suited for abrasive materials, stone or concrete.

d ₁	d ₁ (inch)	T _{max}	pcs/PU	Item no.	€ / PU
85	3-11/32	300	1	529.0852	241,73
110	4-11/32	300	1	529.1102	303,82
121	4-3/4	300	1	529.1212	327,11
130	5-1/8	300	1	529.1302	347,51
140	5-1/2	300	1	529.1402	396,96
152	6	300	1	529.1522	435,77
160	6-5/16	300	1	529.1602	451,29
170	6-11/16	300	1	529.1702	490,09
180	7-3/32	300	1	529.1802	514,51
200	7-7/8	300	1	529.2002	552,18

BiM-Co Roofers' pipe hole saw, 150mm (4/6)



Execution: BiM-Co (Bi-metal with 8% Co alloy), roofers' pipe hole saw with variable pitch (4/6 TPI) and 1/2"-14 BSP(G) connection. Supplied with hexagon shank adapter (779.0050) and pilot auger bit (240.2000).

Application: For sawing fast and precise holes (for exhaust pipes of heating systems or waste air pipes in sanitary systems) in (sloped) roofs. Not suited for abrasive materials, stone or concrete.

d ₁	d ₁ (inch)	T _{max}	pcs/PU	Item no.	€ / PU
85	3-11/32	150	1	529.0851	233,97
110	4-11/32	150	1	529.1101	296,05
121	4-3/4	150	1	529.1211	319,34
130	5-1/8	150	1	529.1301	342,63
140	5-1/2	150	1	529.1401	381,44
152	6	150	1	529.1521	420,25
160	6-5/16	150	1	529.1601	435,77
170	6-11/16	150	1	529.1701	466,82
200	7-7/8	150	1	529.2001	528,90

BiM-Co Construction pipe hole saw, 300mm (3/4)



Execution: BiM-Co (Bi-metal with 8% Co alloy), construction pipe hole saw with variable pitch (3/4 TPI) and 1/2"-14 BSP(G) connection. Supplied with hexagon shank adapter (779.0050) and pilot auger bit (240.2001S). Can also be used with HSS twisted drill bit (160.1203) as pilot drill (sold separately).

Application: For sawing fast and precise holes in wood.
PS: As soon as the hole saw has penetrated about 1cm into the wood, the pilot drill bit has to be removed before sawing is resumed.

d ₁	d ₁ (inch)	T _{max}	pcs/PU	Item no.	€ / PU
85	3-11/32	300	1	529.4085	241,73
110	4-11/32	300	1	529.4110	303,82
130	5-1/8	300	1	529.4130	359,92
152	6	300	1	529.4152	435,77

BiM-Co Construction pipe hole saw, 150mm (3/4)



Execution: BiM-Co (Bi-metal with 8% Co alloy), construction pipe hole saw with variable pitch [3/4 TPI] and 1/2"-14 BSP(G) connection. Supplied with hexagon shank adapter (779.0050) and pilot auger bit (240.2000).

Application: For sawing fast and precise holes in wood.
PS: As soon as the hole saw has penetrated about 1cm into the wood, the pilot drill bit has to be removed before sawing is resumed.

d ₁	d ₁ (inch)	T _{max}	pcs/PU	Item no.	€ / PU
85	3-11/32	150	1	529.3085	233,97
110	4-11/32	150	1	529.3110	296,05
130	5-1/8	150	1	529.3130	342,63
152	6	150	1	529.3152	420,25

TCT Roofers' pipe hole saw, 300mm



Execution: TCT Construction pipe hole saws were specifically developed for making holes quickly and efficiently in (sloping) roofs made of wood and insulation materials. Drills effortlessly double the number of holes than any other existing models and in less than half the time! Equipped with M16 connection type.

Application: For drilling holes in (sloping) roofs for mounting ventilation and exhaust pipes. Not suited for drilling in metals and abrasive materials such as (hard) stone and concrete. Materials like aerated concrete, bricks, soft stones and tiles (max. core hardness of δ) can be drilled.

d ₁	d ₁ (inch)	T _{max}	pcs/PU	Item no.	€ / PU
80	3-5/32	300	1	529.6080	270,14
100	3-15/16	300	1	529.6100	327,01
110	4-11/32	300	1	529.6110	352,60
130	5-1/8	300	1	529.6130	414,69
150	5-29/32	300	1	529.6150	497,62
160	6-5/16	300	1	529.6160	545,96
170	6-11/16	300	1	529.6170	573,60
200	7-7/8	300	1	529.6200	648,33

BiM-Co Ventilation pipe hole saw, 100mm (8/12)



Execution: BiM-Co (Bi-metal with 8% Co alloy), ventilation pipe hole saw with variable pitch [8/12 TPI] and 1/2"-14 BSP(G) connection. Supplied with hexagon shank adapter (779.0050) and pilot drill bit (150.1200).

Application: Due to the fine variable pitched toothing excellent results in plastic pipes and aircondition/ventilation ducts.

d ₁	d ₁ (inch)	T _{max}	pcs/PU	Item no.	€ / PU
85	3-11/32	100	1	529.5085	233,97
110	4-11/32	100	1	529.5110	296,05
130	5-1/8	100	1	529.5130	342,63
160	6-5/16	100	1	529.5160	435,77
178	7	100	1	529.5178	482,34
200	7-7/8	100	1	529.5200	528,90
221	8-23/32	100	1	529.5221	567,70

BiM-Co Special pipe hole saw (4/6)

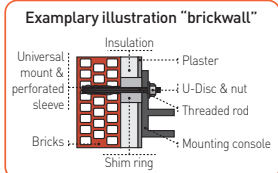
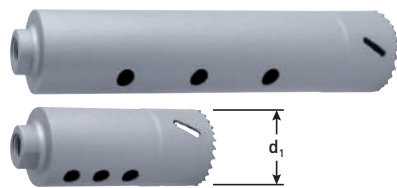

Execution: BiM-Co (Bi-metal with 8% Co alloy), special hole saw with variable pitch (4/6 TPI) and M16 connection for the facade building industry. Hexagon shank adapter (769.0002) is not included!

Application: For making centre holes for spacer sleeves in insulation material for a technical correct installation of facades on buildings (refer to drawing).

d ₁	d ₁ (inch)	T _{max}	pcs/PU	Item no.	€ / PU
50	2	100	1	529.7511	156,31
50	2	250	1	529.7512	208,53



BiM-Co Roller shutter hole saw, wood (4/6)



Execution: BiM-Co (Bi-metal with 8% Co alloy), roller shutter hole saw with variable pitch (4/6 TPI) and M16 connection. Supplied with hexagon shank adapter (769.0002) and pilot drill bit (150.0700). Coated with PTFE to reduce friction and to protect from rusting.

Application: For making holes in wooden window frames in order to feed through the belt of roller shutters.

d ₁	d ₁ (inch)	T _{max}	pcs/PU	Item no.	€ / PU
17	11/16	90	1	529.0170	141,56
25	1	90	1	529.0240	141,56



BiM-Co Roller shutter hole saw, plastic (8/12)



Execution: BiM-Co (Bi-metal with 8% Co alloy), roller shutter hole saw with variable pitch (8/12 TPI) and M16 connection. Supplied with hexagon shank adapter (769.0002) and pilot drill bit (529.0599). Coated with PTFE to reduce friction and to protect from rusting.

Application: For making holes in plastic window frames in order to feed through the belt of roller shutters.

d ₁	d ₁ (inch)	T _{max}	pcs/PU	Item no.	€ / PU
17	11/16	90	1	529.0517	131,50
19	3/4	90	1	529.0519	131,50
22	7/8	90	1	529.0522	131,50



Adapter for pipe hole saws

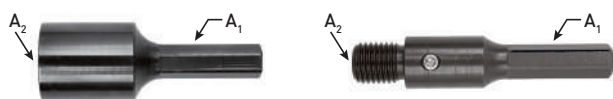

A ₁	A ₂	pcs/PU	Item no.	€ / PU
HEX 13	M16 (ext.)	1	769.0002	14,54
HEX 12,7	1/2" (F)	1	779.0050	40,05

Adjustable hole saw



Execution: Adjustable hole saw, complete in a case

Application: For sawing holes in wood, plastics, gypsum and aluminium. Ideal for installing spotlights.

d (min-max)	T _{max}	pcs/PU	Item no.	€ / PU
ø30 - 130	23	1	529.8130	258,30
ø30 - 290	23	1	529.8290	323,99
ø48 - 426	23	1	529.8426	482,37



Execution: Spare blades for adjustable hole saws.

Description	pcs/PU	Item no.	€ / PU
HSS blade for wood	1	529.8990	54,55
Tungsten carbide blade for aluminium	1	529.8991	54,55

534

TCT Hole saw 'Easy' 12mm

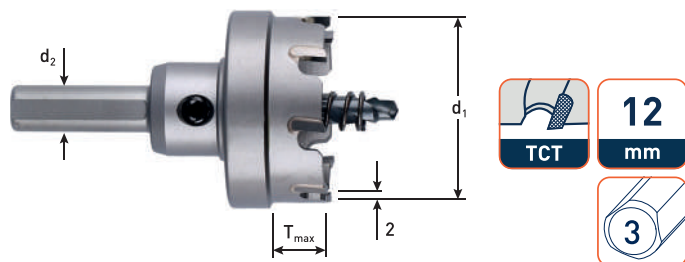

Execution: Tungsten carbide tipped hole saw. Thin cutting width of only 2mm results in low cutting forces, therefore ideal for handheld (cordless) power tools, even up to diameter 80mm! Supplied with fixed arbor, exchangeable pilot drill bit (1 pc) and ejector spring (1 pc).

Application: Steels and stainless steels, max. 5 mm depth of cut. Non-ferrous materials like (fibre reinforced) plastics, aluminium, sandwich panels up to maximum depth of 11mm (remove ejector spring). If applied on thicker materials, remove chips every 2-3 mm depth of cut.

For all metals: use only a good cutting oil.

d ₁	T _{max}	d ₂	pcs/PU	Item no.	€/ PU
14,0	12	10	1	534.0140	36,34
15,0	12	10	1	534.0150	36,34
16,0	12	10	1	534.0160	36,34
17,0	12	10	1	534.0170	36,34
18,0	12	10	1	534.0180	36,34
19,0	12	10	1	534.0190	36,34
20,0	12	10	1	534.0200	36,34
21,0	12	10	1	534.0210	36,34
22,0	12	10	1	534.0220	36,34
23,0	12	10	1	534.0230	36,34
24,0	12	10	1	534.0240	36,34
25,0	12	10	1	534.0250	36,34
26,0	12	10	1	534.0260	36,34
27,0	12	10	1	534.0270	36,34
28,0	12	10	1	534.0280	36,34
29,0	12	10	1	534.0290	36,34
30,0	12	10	1	534.0300	36,34
31,0	12	10	1	534.0310	36,58
32,0	12	10	1	534.0320	36,58
33,0	12	10	1	534.0330	36,58
34,0	12	10	1	534.0340	36,58
35,0	12	10	1	534.0350	36,58
36,0	12	10	1	534.0360	43,40
37,0	12	10	1	534.0370	43,40
38,0	12	10	1	534.0380	43,40
39,0	12	10	1	534.0390	43,40
40,0	12	10	1	534.0400	43,40
41,0	12	10	1	534.0410	44,16

d ₁	T _{max}	d ₂	pcs/PU	Item no.	€/ PU
42,0	12	10	1	534.0420	44,16
43,0	12	10	1	534.0430	44,31
44,0	12	10	1	534.0440	44,31
45,0	12	10	1	534.0450	44,31
46,0	12	10	1	534.0460	49,01
47,0	12	10	1	534.0470	49,01
48,0	12	10	1	534.0480	49,01
49,0	12	10	1	534.0490	49,01
50,0	12	10	1	534.0500	49,01
51,0	12	10	1	534.0510	51,37
52,0	12	10	1	534.0520	51,37
53,0	12	10	1	534.0530	51,83
54,0	12	10	1	534.0540	51,83
55,0	12	10	1	534.0550	51,83
60,0	12	10	1	534.0600	58,87
61,0	12	10	1	534.0610	64,40
65,0	12	13	1	534.0650	64,40
66,0	12	13	1	534.0660	74,82
67,0	12	13	1	534.0670	74,82
68,0	12	13	1	534.0680	74,82
70,0	12	13	1	534.0700	74,82
75,0	12	13	1	534.0750	81,35
80,0	12	13	1	534.0800	88,31
85,0	12	13	1	534.0850	98,12
90,0	12	13	1	534.0900	98,12
95,0	12	13	1	534.0950	107,40
100,0	12	13	1	534.1000	110,85

Pilot drill bit for 'Easy' 12mm



d ₁	l ₁	For hole saws	pcs/PU	Item no.	€/ PU
6	48	534.xxx0 (ø14-100)	1	534.9000	5,89

TCT Hole saw set 'Easy' 12mm



Execution: Plastic case equipped with 6 thin-walled TCT hole saws with a cutting width of 2 mm. Therefore suitable for use in the hand drill up to diameter 50mm. All models fitted with a fixed adapter and interchangeable centre drill. Remove the ejector spring to use the maximum cutting depth. For thicker material, release after every 2-3mm to remove chips.

Application: For drilling in high-quality materials such as (un)alloyed steel, stainless steel, non-ferrous metals and (fibre-reinforced) plastics. Steel and stainless steel max. 5 mm thick, all other materials max. 10 mm thick.

Description	Type	Content	pcs/PU	Item no.	€/ PU
9 pc TCT hole saw set 12mm	534	1x ø16, ø20, ø25, ø32, ø40, ø50 2x pilot drill ø6 1x Allen key	1	534.9010	244,12

TCT Hole saw 'Easy' 26mm

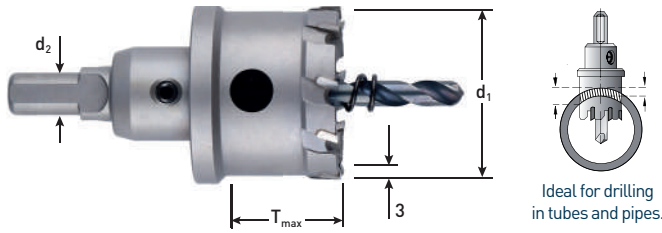

Execution: Tungsten carbide tipped hole saw. Thin cutting width of only 3mm results in low cutting forces, therefore ideal for handheld (cordless) power tools, even up to diameter 100mm! Supplied with fixed arbor, exchangeable pilot drill bit (1 pc) and ejector spring (1 pc).

Application: Steels and stainless steels, max. 5 mm depth of cut. Non-ferrous materials like (fibre reinforced) plastics, aluminium, sandwich panels up to maximum depth of 11mm (remove ejector spring). If applied on thicker materials, remove chips every 2-3 mm depth of cut.

For all metals: use only a good cutting oil.



d ₁	T _{max}	d ₂	pcs/PU	Item no.	€/ PU
16,0	26	10	1	534.0161	51,83
17,0	26	10	1	534.0171	51,83
18,0	26	10	1	534.0181	51,83
19,0	26	10	1	534.0191	51,83
20,0	26	10	1	534.0201	51,83
21,0	26	10	1	534.0211	51,83
22,0	26	10	1	534.0221	51,83
23,0	26	10	1	534.0231	51,83
24,0	26	10	1	534.0241	51,83
25,0	26	10	1	534.0251	51,83
26,0	26	10	1	534.0261	51,83
27,0	26	10	1	534.0271	51,83
28,0	26	10	1	534.0281	51,83
29,0	26	10	1	534.0291	51,83
30,0	26	10	1	534.0301	51,83
31,0	26	10	1	534.0311	51,98
32,0	26	10	1	534.0321	51,98
33,0	26	10	1	534.0331	51,98
34,0	26	10	1	534.0341	51,98
35,0	26	10	1	534.0351	51,98
36,0	26	10	1	534.0361	51,98
37,0	26	10	1	534.0371	51,98
38,0	26	10	1	534.0381	51,98

d ₁	T _{max}	d ₂	pcs/PU	Item no.	€/ PU
39,0	26	10	1	534.0391	51,98
40,0	26	10	1	534.0401	51,98
41,0	26	10	1	534.0411	56,88
42,0	26	10	1	534.0421	56,88
43,0	26	10	1	534.0431	56,88
44,0	26	10	1	534.0441	57,04
45,0	26	10	1	534.0451	57,04
50,0	26	10	1	534.0501	57,95
51,0	26	10	1	534.0511	57,95
53,0	26	10	1	534.0531	58,66
54,0	26	10	1	534.0541	58,66
55,0	26	10	1	534.0551	58,66
60,0	26	10	1	534.0601	70,08
61,0	26	13	1	534.0611	77,35
65,0	26	13	1	534.0651	77,35
68,0	26	13	1	534.0681	88,25
70,0	26	13	1	534.0701	88,25
75,0	26	13	1	534.0751	94,38
80,0	26	13	1	534.0801	102,97
85,0	26	13	1	534.0851	115,08
90,0	26	13	1	534.0901	117,90
95,0	26	13	1	534.0951	124,49
100,0	26	13	1	534.1001	126,18

Pilot drill bit for 'Easy' 26mm



d ₁	l ₁	For hole saws	pcs/PU	Item no.	€/ PU
6	76	534.xxx1 (ø16-100)	1	534.9005	6,48

535

TCT Hole saw 'Heavy-Duty' 30mm

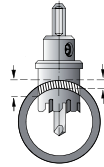
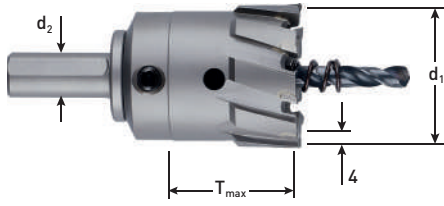

Ideal for drilling in tubes and pipes.



Execution: Tungsten carbide tipped hole saw with super heavy duty body and 4mm cutting width. For use in handheld power tools (up to ø40) and stationary machines (drill presses, magnetic core drills). Supplied with fixed arbor, exchangeable pilot drill bit (1 pc) and ejector spring (1 pc).

Application: Steels and stainless steels, max. 20 mm depth of cut. Non-ferrous materials like (fibre reinforced) plastics, aluminium, sandwich panels up to maximum depth of 30mm (remove ejector spring). If applied on thicker materials, remove chips whenever necessary. For flat materials, tubes and curved surfaces. Drilling with overlap is no problem.

For all metals: use only a good cutting oil.

d ₁	T _{max}	d ₂	pcs/PU	Item no.	€ / PU
14,0	30	13	1	535.0140	57,58
15,0	30	13	1	535.0150	57,58
16,0	30	13	1	535.0160	57,58
17,0	30	13	1	535.0170	57,58
18,0	30	13	1	535.0180	57,58
19,0	30	13	1	535.0190	57,58
20,0	30	13	1	535.0200	57,58
21,0	30	13	1	535.0210	57,58
22,0	30	13	1	535.0220	57,58
23,0	30	13	1	535.0230	57,58
24,0	30	13	1	535.0240	57,58
25,0	30	13	1	535.0250	57,58
26,0	30	13	1	535.0260	57,58
27,0	30	13	1	535.0270	57,58
28,0	30	13	1	535.0280	57,58
29,0	30	13	1	535.0290	57,58
30,0	30	13	1	535.0300	57,58
31,0	30	13	1	535.0310	57,75
32,0	30	13	1	535.0320	57,75
33,0	30	13	1	535.0330	57,75
34,0	30	13	1	535.0340	57,75
35,0	30	13	1	535.0350	57,75
36,0	30	13	1	535.0360	57,75
37,0	30	13	1	535.0370	57,75

d ₁	T _{max}	d ₂	pcs/PU	Item no.	€ / PU
38,0	30	13	1	535.0380	57,75
39,0	30	13	1	535.0390	57,75
40,0	30	13	1	535.0400	57,75
41,0	30	13	1	535.0410	63,21
42,0	30	13	1	535.0420	63,21
43,0	30	13	1	535.0430	63,21
44,0	30	13	1	535.0440	63,37
45,0	30	13	1	535.0450	63,37
46,0	30	13	1	535.0460	64,40
47,0	30	13	1	535.0470	64,40
48,0	30	13	1	535.0480	64,40
49,0	30	13	1	535.0490	64,40
50,0	30	13	1	535.0500	64,40
51,0	30	13	1	535.0510	64,40
52,0	30	13	1	535.0520	64,40
53,0	30	13	1	535.0530	65,18
54,0	30	13	1	535.0540	65,18
55,0	30	13	1	535.0550	65,18
56,0	30	13	1	535.0560	77,85
57,0	30	13	1	535.0570	77,85
58,0	30	13	1	535.0580	77,85
59,0	30	13	1	535.0590	77,85
60,0	30	13	1	535.0600	77,85

Pilot drill bit for 'Heavy-Duty' 30mm



d ₁	l ₁	For hole saws	pcs/PU	Item no.	€ / PU
6	80	535.xxx0 (ø14-60)	1	535.9008	6,48

TCT Hole saw 'Heavy-Duty' 55mm

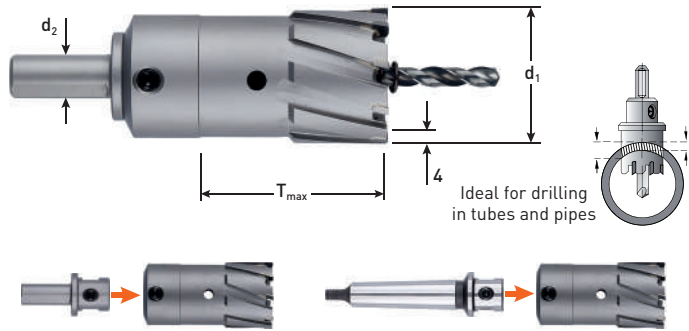

Execution: Tungsten carbide tipped hole saw with super heavy duty body and 4mm cutting width. For use in handheld power tools (up to ø40) and stationary machines (drill presses, magnetic core drills). Supplied with fixed arbor, exchangeable pilot drill bit (1 pc) and ejector spring (1 pc).

Application: Steels and stainless steels, max. 20 mm depth of cut. Non-ferrous materials like (fibre reinforced) plastics, aluminium, sandwich panels up to maximum depth of 55mm (remove ejector spring). If applied on thicker materials, remove chips whenever necessary. For flat materials, tubes and curved surfaces. Drilling with overlap is no problem.

For all metals: use only a good cutting oil.

d ₁	T _{max}	d ₂	pcs/PU	Item no.	€ / PU
18,0	55	13	1	535.0181	69,67
20,0	55	13	1	535.0201	69,67
22,0	55	13	1	535.0221	69,67
25,0	55	13	1	535.0251	69,67
30,0	55	13	1	535.0301	69,67
35,0	55	13	1	535.0351	69,94
40,0	55	13	1	535.0401	69,94
45,0	55	13	1	535.0451	76,60
50,0	55	13	1	535.0501	78,03
55,0	55	13	1	535.0551	78,81
60,0	55	13	1	535.0601	94,03
65,0	55	13	1	535.0651	106,07
68,0	55	13	1	535.0681	117,90

d ₁	T _{max}	d ₂	pcs/PU	Item no.	€ / PU
70,0	55	13	1	535.0701	119,34
75,0	55	13	1	535.0751	127,74
80,0	55	13	1	535.0801	140,21
85,0	55	13	1	535.0851	156,32
90,0	55	13	1	535.0901	160,06
95,0	55	13	1	535.0951	168,82
100,0	55	13	1	535.1001	171,14
105,0	55	13	1	535.1051	190,28
110,0	55	13	1	535.1101	223,26
115,0	55	13	1	535.1151	261,25
120,0	55	13	1	535.1201	295,56
125,0	55	13	1	535.1251	322,99

Pilot drill bit for 'Heavy-Duty' 55mm



d ₁	l ₁	For hole saws	pcs/PU	Item no.	€ / PU
6	110	535.xxx1 (ø18-60)	1	535.9016	11,49
8	110	535.xxx1 (ø65-125)	1	535.9018	15,16

Holder for TCT hole saws

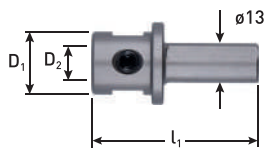

D ₁	l ₁	D ₂	For hole saws	pcs/PU	Item no.	€ / PU
20	53	6	535 (ø18-60)	1	535.9000	10,05
20	53	8	535 (ø65-100)	1	535.9001	10,05
32	57	8	535 (ø105-125)	1	535.9014	18,67



D ₁	M ₁	l ₁	For hole saws	pcs/PU	Item no.	€ / PU
20	MT 2	108	535 (ø18-100)	1	535.9003	30,60
32	MT 3	133	535 (ø105-125)	1	535.9108	56,66

536

HSS Annular cutter SILVER-LINE 30mm (WLD)



Execution: SILVER-LINE annular cutter, made of high grade HSS, fully ground execution, uncoated, bright finish. Stage hardened with very hard (up to 68 HRC) and wear resistant cutting edges while maintaining a tough body to allow high-torque applications. Excellent chip evacuation and self-centering properties.

Weldon 19mm (¾") shank.

Application: For drilling holes in construction steels, low-carbon steels and cast steels up to 750 N/mm².
Material groups : 1.1 - 1.3

d ₁	T _{max}	A ₁	pcs/PU	Item no.	€ / PU
12,0	30	WLD 19	1	536.1200W	19,90
13,0	30	WLD 19	1	536.1300W	19,90
14,0	30	WLD 19	1	536.1400W	20,24
15,0	30	WLD 19	1	536.1500W	20,24
16,0	30	WLD 19	1	536.1600W	21,54
17,0	30	WLD 19	1	536.1700W	21,54
18,0	30	WLD 19	1	536.1800W	22,51
19,0	30	WLD 19	1	536.1900W	22,51
20,0	30	WLD 19	1	536.2000W	24,45
21,0	30	WLD 19	1	536.2100W	24,45
22,0	30	WLD 19	1	536.2200W	30,01
23,0	30	WLD 19	1	536.2300W	30,01
24,0	30	WLD 19	1	536.2400W	31,32
25,0	30	WLD 19	1	536.2500W	31,32
26,0	30	WLD 19	1	536.2600W	33,98
27,0	30	WLD 19	1	536.2700W	34,05
28,0	30	WLD 19	1	536.2800W	36,44
29,0	30	WLD 19	1	536.2900W	36,44
30,0	30	WLD 19	1	536.3000W	38,30
31,0	30	WLD 19	1	536.3100W	38,30
32,0	30	WLD 19	1	536.3200W	39,95
33,0	30	WLD 19	1	536.3300W	39,95
34,0	30	WLD 19	1	536.3400W	42,13
35,0	30	WLD 19	1	536.3500W	42,13
36,0	30	WLD 19	1	536.3600W	47,74

d ₁	T _{max}	A ₁	pcs/PU	Item no.	€ / PU
37,0	30	WLD 19	1	536.3700W	50,66
38,0	30	WLD 19	1	536.3800W	54,35
39,0	30	WLD 19	1	536.3900W	54,35
40,0	30	WLD 19	1	536.4000W	59,63
41,0	30	WLD 19	1	536.4100W	59,63
42,0	30	WLD 19	1	536.4200W	64,40
43,0	30	WLD 19	1	536.4300W	64,40
44,0	30	WLD 19	1	536.4400W	70,71
45,0	30	WLD 19	1	536.4500W	70,71
46,0	30	WLD 19	1	536.4600W	76,06
47,0	30	WLD 19	1	536.4700W	76,06
48,0	30	WLD 19	1	536.4800W	80,23
49,0	30	WLD 19	1	536.4900W	80,23
50,0	30	WLD 19	1	536.5000W	85,77
51,0	30	WLD 19	1	536.5100W	85,77
52,0	30	WLD 19	1	536.5200W	93,03
53,0	30	WLD 19	1	536.5300W	95,95
54,0	30	WLD 19	1	536.5400W	98,91
55,0	30	WLD 19	1	536.5500W	101,26
56,0	30	WLD 19	1	536.5600W	104,95
57,0	30	WLD 19	1	536.5700W	108,65
58,0	30	WLD 19	1	536.5800W	111,36
59,0	30	WLD 19	1	536.5900W	114,84
60,0	30	WLD 19	1	536.6000W	118,30
65,0	30	WLD 32	1	536.6500W	132,72

545

Ejector pin 30mm

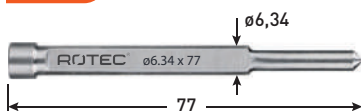

Dimensions (mm)	d (min-max)	pcs/PU	Item no.	€ / PU
ø6,34 x 77mm	ø12 - 65mm	1	545.0030	6,56

536

HSS Annular cutter set SILVER-LINE 30mm (WLD), in plastic case



Execution: SILVER-LINE annular cutter, made of high grade HSS, fully ground execution, uncoated, bright finish. Stage hardened with very hard (up to 68 HRC) and wear resistant cutting edges while maintaining a tough body to allow high-torque applications. Excellent chip evacuation and self-centering properties.

Weldon 19mm (¾") shank.

Application: For drilling holes in construction steels, low-carbon steels and cast steels up to 750 N/mm².
Material groups : 1.1 - 1.3

Description	Type	Content	pcs/PU	Item no.	€ / PU
7 pc annular cutter set, 30mm	536W	1x ø12, 14, 16, 18, 20 and 22mm 1x ejector pin	1	536.9001	140,13
6 pc annular cutter set, 30mm	536W	1x ø24, 26, 28, 30 and 32mm 1x ejector pin	1	536.9006	180,30

536

HSS Annular cutter SILVER-LINE 55mm (WLD)



Execution: SILVER-LINE annular cutter, made of high grade HSS, fully ground execution, uncoated, bright finish. Stage hardened with very hard (up to 68 HRC) and wear resistant cutting edges while maintaining a tough body to allow high-torque applications. Excellent chip evacuation and self-centering properties.

Weldon 19mm (¾") shank.

Application: For drilling holes in construction steels, low-carbon steels and cast steels up to 750 N/mm².
Material groups : 1.1 - 1.3

d ₁	T _{max}	A ₁	pcs/PU	Item no.	€ / PU
12,0	55	WLD 19	1	536.1201W	25,81
13,0	55	WLD 19	1	536.1301W	25,81
14,0	55	WLD 19	1	536.1401W	26,72
15,0	55	WLD 19	1	536.1501W	26,72
16,0	55	WLD 19	1	536.1601W	27,52
17,0	55	WLD 19	1	536.1701W	27,52
18,0	55	WLD 19	1	536.1801W	29,73
19,0	55	WLD 19	1	536.1901W	29,73
20,0	55	WLD 19	1	536.2001W	32,06
21,0	55	WLD 19	1	536.2101W	32,06
22,0	55	WLD 19	1	536.2201W	36,10
23,0	55	WLD 19	1	536.2301W	36,10
24,0	55	WLD 19	1	536.2401W	38,25
25,0	55	WLD 19	1	536.2501W	38,25
26,0	55	WLD 19	1	536.2601W	41,16
27,0	55	WLD 19	1	536.2701W	41,22
28,0	55	WLD 19	1	536.2801W	44,79
29,0	55	WLD 19	1	536.2901W	44,79
30,0	55	WLD 19	1	536.3001W	47,06
31,0	55	WLD 19	1	536.3101W	47,06
32,0	55	WLD 19	1	536.3201W	50,31
33,0	55	WLD 19	1	536.3301W	55,34
34,0	55	WLD 19	1	536.3401W	56,35
35,0	55	WLD 19	1	536.3501W	56,35
36,0	55	WLD 19	1	536.3601W	60,77

d ₁	T _{max}	A ₁	pcs/PU	Item no.	€ / PU
37,0	55	WLD 19	1	536.3701W	65,09
38,0	55	WLD 19	1	536.3801W	69,07
39,0	55	WLD 19	1	536.3901W	69,07
40,0	55	WLD 19	1	536.4001W	75,55
41,0	55	WLD 19	1	536.4101W	75,55
42,0	55	WLD 19	1	536.4201W	81,74
43,0	55	WLD 19	1	536.4301W	81,74
44,0	55	WLD 19	1	536.4401W	89,75
45,0	55	WLD 19	1	536.4501W	94,24
46,0	55	WLD 19	1	536.4601W	96,42
47,0	55	WLD 19	1	536.4701W	96,42
48,0	55	WLD 19	1	536.4801W	101,83
49,0	55	WLD 19	1	536.4901W	101,83
50,0	55	WLD 19	1	536.5001W	114,91
51,0	55	WLD 19	1	536.5101W	121,80
52,0	55	WLD 19	1	536.5201W	126,48
53,0	55	WLD 19	1	536.5301W	130,44
54,0	55	WLD 19	1	536.5401W	129,68
55,0	55	WLD 19	1	536.5501W	133,21
56,0	55	WLD 19	1	536.5601W	142,59
57,0	55	WLD 19	1	536.5701W	146,12
58,0	55	WLD 19	1	536.5801W	150,08
59,0	55	WLD 19	1	536.5901W	153,48
60,0	55	WLD 19	1	536.6001W	157,90

545

Ejector pin 55mm

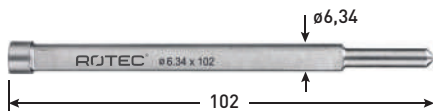

Dimensions (mm)	d (min-max)	pcs/PU	Item no.	€ / PU
ø6,34 x 102mm	ø12 - 60mm	1	545.0031	7,60

536

HSS-XE Annular cutter SILVER-LINE 30mm (WLD)

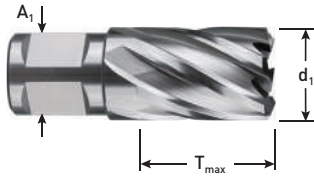

Execution: SILVER-LINE annular cutter, made of high grade HSS-XE, fully ground execution, uncoated, bright finish. Stage hardened with very hard (up to 68 HRC) and wear resistant cutting edges while maintaining a tough body to allow high-torque applications. Excellent chip evacuation and self-centering properties.

Weldon 19mm (¾") shank.

Application: For drilling holes in construction steels, low-carbon steels and cast steels up to 750 N/mm². Material groups : 1.1 - 1.3

d ₁	T _{max}	A ₁	pcs/PU	Item no.	€ / PU
12,0	30	WLD 19	1	536.1200	21,47
13,0	30	WLD 19	1	536.1300	21,47
14,0	30	WLD 19	1	536.1400	21,84
15,0	30	WLD 19	1	536.1500	21,84
16,0	30	WLD 19	1	536.1600	23,24
17,0	30	WLD 19	1	536.1700	23,24
18,0	30	WLD 19	1	536.1800	25,52
19,0	30	WLD 19	1	536.1900	25,52
20,0	30	WLD 19	1	536.2000	27,70
21,0	30	WLD 19	1	536.2100	27,70
22,0	30	WLD 19	1	536.2200	32,37
23,0	30	WLD 19	1	536.2300	32,37
24,0	30	WLD 19	1	536.2400	33,80
25,0	30	WLD 19	1	536.2500	33,80
26,0	30	WLD 19	1	536.2600	36,66
27,0	30	WLD 19	1	536.2700	38,57
28,0	30	WLD 19	1	536.2800	39,31
29,0	30	WLD 19	1	536.2900	41,28
30,0	30	WLD 19	1	536.3000	41,33
31,0	30	WLD 19	1	536.3100	43,40
32,0	30	WLD 19	1	536.3200	45,26
33,0	30	WLD 19	1	536.3300	43,10
34,0	30	WLD 19	1	536.3400	45,44
35,0	30	WLD 19	1	536.3500	45,44
36,0	30	WLD 19	1	536.3600	51,51

d ₁	T _{max}	A ₁	pcs/PU	Item no.	€ / PU
37,0	30	WLD 19	1	536.3700	54,64
38,0	30	WLD 19	1	536.3800	58,64
39,0	30	WLD 19	1	536.3900	58,64
40,0	30	WLD 19	1	536.4000	64,33
41,0	30	WLD 19	1	536.4100	64,33
42,0	30	WLD 19	1	536.4200	69,47
43,0	30	WLD 19	1	536.4300	69,47
44,0	30	WLD 19	1	536.4400	76,28
45,0	30	WLD 19	1	536.4500	76,28
46,0	30	WLD 19	1	536.4600	82,05
47,0	30	WLD 19	1	536.4700	82,05
48,0	30	WLD 19	1	536.4800	86,54
49,0	30	WLD 19	1	536.4900	86,54
50,0	30	WLD 19	1	536.5000	92,54
51,0	30	WLD 19	1	536.5100	92,54
52,0	30	WLD 19	1	536.5200	100,34
53,0	30	WLD 19	1	536.5300	103,51
54,0	30	WLD 19	1	536.5400	106,71
55,0	30	WLD 19	1	536.5500	109,23
56,0	30	WLD 19	1	536.5600	113,22
57,0	30	WLD 19	1	536.5700	117,20
58,0	30	WLD 19	1	536.5800	120,13
59,0	30	WLD 19	1	536.5900	123,88
60,0	30	WLD 19	1	536.6000	127,64

545

Ejector pin 30mm

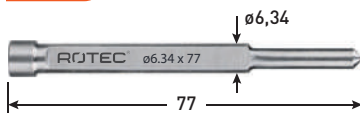

Dimensions (mm)	d (min-max)	pcs/PU	Item no.	€ / PU
ø6,34 x 77mm	ø12 - 65mm	1	545.0030	6,56

536

HSS-XE Annular cutter set SILVER-LINE 30mm (WLD), in plastic case



Execution: SILVER-LINE annular cutter, made of high grade HSS-XE, fully ground execution, uncoated, bright finish. Stage hardened with very hard (up to 68 HRC) and wear resistant cutting edges while maintaining a tough body to allow high-torque applications. Excellent chip evacuation and self-centering properties.

Weldon 19mm (¾") shank.

Application: For drilling holes in construction steels, low-carbon steels and cast steels up to 750 N/mm². Material groups : 1.1 - 1.3

Description	Type	Content	pcs/PU	Item no.	€ / PU
7 pc annular cutter set, 30mm	536	1x ø12, 14, 16, 18, 20 and 22mm 1x ejector pin	1	536.9000	155,69
6 pc annular cutter set, 30mm	536	1x ø24, 26, 28, 30 and 32mm 1x ejector pin	1	536.9005	202,34

536

HSS-XE Annular cutter SILVER-LINE 55mm (WLD)

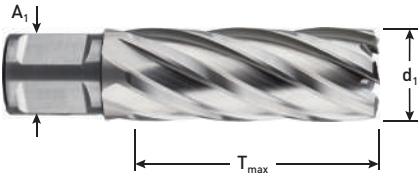

Execution: SILVER-LINE annular cutter, made of high grade HSS-XE, fully ground execution, uncoated, bright finish. Stage hardened with very hard (up to 68 HRC) and wear resistant cutting edges while maintaining a tough body to allow high-torque applications. Excellent chip evacuation and self-centering properties.

Weldon 19mm (¾") shank.

Application: For drilling holes in construction steels, low-carbon steels and cast steels up to 750 N/mm².
Material groups : 1.1 - 1.3

d ₁	T _{max}	A ₁	pcs/PU	Item no.	€ / PU
12,0	55	WLD 19	1	536.1201	27,84
13,0	55	WLD 19	1	536.1301	27,84
14,0	55	WLD 19	1	536.1401	28,83
15,0	55	WLD 19	1	536.1501	28,83
16,0	55	WLD 19	1	536.1601	29,68
17,0	55	WLD 19	1	536.1701	29,68
18,0	55	WLD 19	1	536.1801	32,06
19,0	55	WLD 19	1	536.1901	32,06
20,0	55	WLD 19	1	536.2001	34,59
21,0	55	WLD 19	1	536.2101	34,59
22,0	55	WLD 19	1	536.2201	38,94
23,0	55	WLD 19	1	536.2301	38,94
24,0	55	WLD 19	1	536.2401	43,31
25,0	55	WLD 19	1	536.2501	43,31
26,0	55	WLD 19	1	536.2601	44,39
27,0	55	WLD 19	1	536.2701	46,69
28,0	55	WLD 19	1	536.2801	48,31
29,0	55	WLD 19	1	536.2901	50,73
30,0	55	WLD 19	1	536.3001	50,77
31,0	55	WLD 19	1	536.3101	53,31
32,0	55	WLD 19	1	536.3201	54,27
33,0	55	WLD 19	1	536.3301	54,27
34,0	55	WLD 19	1	536.3401	57,89
35,0	55	WLD 19	1	536.3501	60,78
36,0	55	WLD 19	1	536.3601	65,55

d ₁	T _{max}	A ₁	pcs/PU	Item no.	€ / PU
37,0	55	WLD 19	1	536.3701	70,21
38,0	55	WLD 19	1	536.3801	74,51
39,0	55	WLD 19	1	536.3901	74,51
40,0	55	WLD 19	1	536.4001	81,50
41,0	55	WLD 19	1	536.4101	81,50
42,0	55	WLD 19	1	536.4201	88,18
43,0	55	WLD 19	1	536.4301	88,18
44,0	55	WLD 19	1	536.4401	96,83
45,0	55	WLD 19	1	536.4501	96,83
46,0	55	WLD 19	1	536.4601	104,01
47,0	55	WLD 19	1	536.4701	104,01
48,0	55	WLD 19	1	536.4801	109,84
49,0	55	WLD 19	1	536.4901	109,84
50,0	55	WLD 19	1	536.5001	123,95
51,0	55	WLD 19	1	536.5101	123,95
52,0	55	WLD 19	1	536.5201	129,95
53,0	55	WLD 19	1	536.5301	134,00
54,0	55	WLD 19	1	536.5401	138,53
55,0	55	WLD 19	1	536.5501	142,28
56,0	55	WLD 19	1	536.5601	155,38
57,0	55	WLD 19	1	536.5701	150,12
58,0	55	WLD 19	1	536.5801	154,17
59,0	55	WLD 19	1	536.5901	167,19
60,0	55	WLD 19	1	536.6001	162,20

545

Ejector pin 55mm

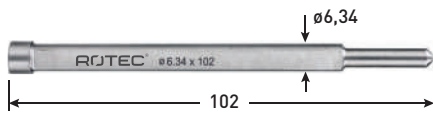

Dimensions (mm)	d (min-max)	pcs/PU	Item no.	€ / PU
ø6,34 x 102mm	ø12 - 60mm	1	545.0031	7,60

536

HSS-XE Annular cutter SILVER-LINE 80mm (UNI)

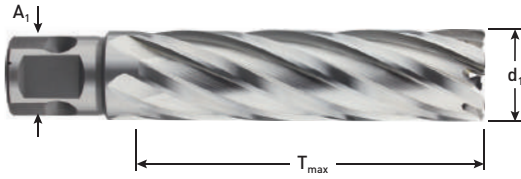

Execution: SILVER-LINE annular cutter, made of high grade HSS-XE, fully ground execution, uncoated, bright finish. Stage hardened with very hard (up to 68 HRC) and wear resistant cutting edges while maintaining a tough body to allow high-torque applications. Excellent chip evacuation and self-centering properties.

Universal 19mm (¾") shank with WELDON and NITTO connections.

Application: For drilling holes in construction steels, low-carbon steels and cast steels up to 750 N/mm². Material groups : 1.1 - 1.3

d ₁	T _{max}	A ₁	pcs/PU	Item no.	€/PU
18,0	80	UNI 19	1	536.1802	60,56
19,0	80	UNI 19	1	536.1902	60,56
20,0	80	UNI 19	1	536.2002	63,02
21,0	80	UNI 19	1	536.2102	63,02
22,0	80	UNI 19	1	536.2202	71,76
23,0	80	UNI 19	1	536.2302	77,06
24,0	80	UNI 19	1	536.2402	75,89
25,0	80	UNI 19	1	536.2502	75,89
26,0	80	UNI 19	1	536.2602	78,59
27,0	80	UNI 19	1	536.2702	82,52
28,0	80	UNI 19	1	536.2802	85,54
29,0	80	UNI 19	1	536.2902	89,82
30,0	80	UNI 19	1	536.3002	94,43

d ₁	T _{max}	A ₁	pcs/PU	Item no.	€/PU
31,0	80	UNI 19	1	536.3102	93,57
32,0	80	UNI 19	1	536.3202	96,14
33,0	80	UNI 19	1	536.3302	100,95
34,0	80	UNI 19	1	536.3402	107,78
35,0	80	UNI 19	1	536.3502	110,81
36,0	80	UNI 19	1	536.3602	119,72
37,0	80	UNI 19	1	536.3702	124,93
38,0	80	UNI 19	1	536.3802	127,02
39,0	80	UNI 19	1	536.3902	131,99
40,0	80	UNI 19	1	536.4002	139,03
45,0	80	UNI 19	1	536.4502	165,11
50,0	80	UNI 19	1	536.5002	211,53

545

Ejector pin 80mm



Dimensions (mm)	d (min-max)	pcs/PU	Item no.	€/PU
ø7,98 x 130mm	ø18 - 60mm	1	545.0034	12,96

536

HSS-XE Annular cutter SILVER-LINE 110mm (UNI)



Execution: SILVER-LINE annular cutter, made of high grade HSS-XE, fully ground execution, uncoated, bright finish. Stage hardened with very hard (up to 68 HRC) and wear resistant cutting edges while maintaining a tough body to allow high-torque applications. Excellent chip evacuation and self-centering properties.

Universal 19mm (¾") shank with WELDON and NITTO connections.

Application: For drilling holes in construction steels, low-carbon steels and cast steels up to 750 N/mm².
Material groups : 1.1 - 1.3

d ₁	T _{max}	A ₁	pcs/PU	Item no.	€ / PU
18,0	110	UNI 19	1	536.1803	76,97
19,0	110	UNI 19	1	536.1903	78,90
20,0	110	UNI 19	1	536.2003	84,20
21,0	110	UNI 19	1	536.2103	85,71
22,0	110	UNI 19	1	536.2203	92,02
23,0	110	UNI 19	1	536.2303	92,02
24,0	110	UNI 19	1	536.2403	100,79
25,0	110	UNI 19	1	536.2503	103,15
26,0	110	UNI 19	1	536.2603	108,44
27,0	110	UNI 19	1	536.2703	110,61
28,0	110	UNI 19	1	536.2803	113,91
29,0	110	UNI 19	1	536.2903	122,78
30,0	110	UNI 19	1	536.3003	127,60
31,0	110	UNI 19	1	536.3103	127,61

d ₁	T _{max}	A ₁	pcs/PU	Item no.	€ / PU
32,0	110	UNI 19	1	536.3203	135,64
33,0	110	UNI 19	1	536.3303	139,51
34,0	110	UNI 19	1	536.3403	141,39
35,0	110	UNI 19	1	536.3503	151,72
36,0	110	UNI 19	1	536.3603	161,47
37,0	110	UNI 19	1	536.3703	169,28
38,0	110	UNI 19	1	536.3803	173,53
39,0	110	UNI 19	1	536.3903	181,23
40,0	110	UNI 19	1	536.4003	191,57
45,0	110	UNI 19	1	536.4503	225,63
50,0	110	UNI 19	1	536.5003	289,91
55,0	110	UNI 19	1	536.5503	319,40
60,0	110	UNI 19	1	536.6003	368,38

545

Ejector pin 110mm

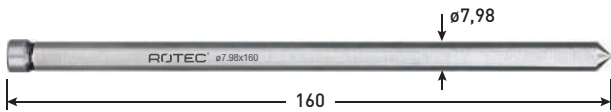

Dimensions (mm)	d (min-max)	pcs/PU	Item no.	€ / PU
ø7,98 x 160mm	ø18 - 60mm	1	545.0032	13,29

537

HSS-XE Annular cutter GOLD-LINE 30mm (UNI)

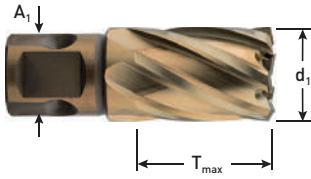

Execution: GOLD-LINE annular cutter, made of high grade alloyed HSS-XE, fully ground execution, Gold-Tech coated. Stage hardened with very hard (up to 68 HRC) and wear resistant cutting edges while maintaining a tough body to allow high-torque applications. Excellent chip evacuation and self-centering properties.

Universal 19mm (¾") shank with WELDON and NITTO connections

Application: For drilling holes in all types of steels up to 900 N/mm² as well as stainless steel, copper, aluminium and plastics.
Material groups : 1.1 - 1.4 / 2.1 - 2.2 / 3.1 - 3.2 / 4.1 - 4.12 / 5.1 / 5.3

d ₁	T _{max}	A ₁	pcs/PU	Item no.	€ / PU
12,0	30	UNI 19	1	537.1200	30,60
13,0	30	UNI 19	1	537.1300	30,60
14,0	30	UNI 19	1	537.1400	31,17
15,0	30	UNI 19	1	537.1500	31,17
16,0	30	UNI 19	1	537.1600	32,37
17,0	30	UNI 19	1	537.1700	32,37
18,0	30	UNI 19	1	537.1800	33,89
19,0	30	UNI 19	1	537.1900	33,89
20,0	30	UNI 19	1	537.2000	35,71
21,0	30	UNI 19	1	537.2100	35,71
22,0	30	UNI 19	1	537.2200	42,35
23,0	30	UNI 19	1	537.2300	42,35
24,0	30	UNI 19	1	537.2400	43,95
25,0	30	UNI 19	1	537.2500	43,95
26,0	30	UNI 19	1	537.2600	46,61
27,0	30	UNI 19	1	537.2700	46,61
28,0	30	UNI 19	1	537.2800	50,19
29,0	30	UNI 19	1	537.2900	50,19
30,0	30	UNI 19	1	537.3000	52,64
31,0	30	UNI 19	1	537.3100	52,64
32,0	30	UNI 19	1	537.3200	54,96
33,0	30	UNI 19	1	537.3300	54,96
34,0	30	UNI 19	1	537.3400	58,02
35,0	30	UNI 19	1	537.3500	58,02
36,0	30	UNI 19	1	537.3600	65,69

d ₁	T _{max}	A ₁	pcs/PU	Item no.	€ / PU
37,0	30	UNI 19	1	537.3700	68,31
38,0	30	UNI 19	1	537.3800	73,35
39,0	30	UNI 19	1	537.3900	73,37
40,0	30	UNI 19	1	537.4000	80,41
41,0	30	UNI 19	1	537.4100	80,41
42,0	30	UNI 19	1	537.4200	86,81
43,0	30	UNI 19	1	537.4300	86,81
44,0	30	UNI 19	1	537.4400	95,33
45,0	30	UNI 19	1	537.4500	95,33
46,0	30	UNI 19	1	537.4600	102,52
47,0	30	UNI 19	1	537.4700	108,69
48,0	30	UNI 19	1	537.4800	108,17
49,0	30	UNI 19	1	537.4900	108,17
50,0	30	UNI 19	1	537.5000	115,59
51,0	30	UNI 19	1	537.5100	115,59
52,0	30	UNI 19	1	537.5200	125,38
53,0	30	UNI 19	1	537.5300	129,30
54,0	30	UNI 19	1	537.5400	133,35
55,0	30	UNI 19	1	537.5500	136,55
56,0	30	UNI 19	1	537.5600	141,49
57,0	30	UNI 19	1	537.5700	146,51
58,0	30	UNI 19	1	537.5800	150,18
59,0	30	UNI 19	1	537.5900	154,85
60,0	30	UNI 19	1	537.6000	159,55

545

Ejector pin 30mm

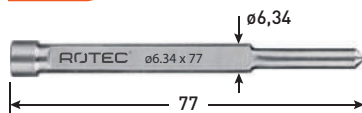

Dimensions (mm)	d (min-max)	pcs/PU	Item no.	€ / PU
ø6,34 x 77mm	ø12 - 65mm	1	545.0030	6,56

537

HSS-XE Annular cutter set GOLD-LINE 30mm (UNI), in plastic case



Execution: GOLD-LINE annular cutter, made of high grade alloyed HSS-XE, fully ground execution, Gold-Tech coated. Stage hardened with very hard (up to 68 HRC) and wear resistant cutting edges while maintaining a tough body to allow high-torque applications. Excellent chip evacuation and self-centering properties.

Universal 19mm (¾") shank with WELDON and NITTO connections

Application: For drilling holes in all types of steels up to 900 N/mm² as well as stainless steel, copper, aluminium and plastics.
Material groups : 1.1 - 1.4 / 2.1 - 2.2 / 3.1 - 3.2 / 4.1 - 4.12 / 5.1 / 5.3

Description	Type	Content	pcs/PU	Item no.	€ / PU
7 pc annular cutter set, 30mm	537	1x ø12, 14, 16, 18, 20 and 22mm 1x ejector pin	1	537.9000	212,22
6 pc annular cutter set, 30mm	537	1x ø24, 26, 28, 30 and 32mm 1x ejector pin	1	537.9005	254,47

537

HSS-XE Annular cutter GOLD-LINE 55mm (UNI)

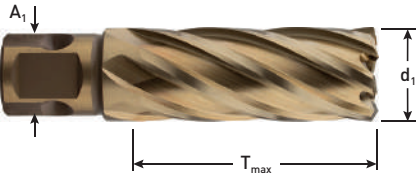

Execution: GOLD-LINE annular cutter, made of high grade alloyed HSS-XE, fully ground execution, Gold-Tech coated. Stage hardened with very hard (up to 68 HRC) and wear resistant cutting edges while maintaining a tough body to allow high-torque applications. Excellent chip evacuation and self-centering properties.

Universal 19mm (¾") shank with WELDON and NITTO connections

Application: For drilling holes in all types of steels up to 900 N/mm² as well as stainless steel, copper, aluminium and plastics.
Material groups : 1.1 - 1.4 / 2.1 - 2.2 / 3.1 - 3.2 / 4.1 - 4.12 / 5.1 / 5.3

d ₁	T _{max}	A ₁	pcs/PU	Item no.	€ / PU
12,0	55	UNI 19	1	537.1201	38,33
13,0	55	UNI 19	1	537.1301	38,33
14,0	55	UNI 19	1	537.1401	39,63
15,0	55	UNI 19	1	537.1501	39,63
16,0	55	UNI 19	1	537.1601	40,71
17,0	55	UNI 19	1	537.1701	40,71
18,0	55	UNI 19	1	537.1801	42,35
19,0	55	UNI 19	1	537.1901	42,35
20,0	55	UNI 19	1	537.2001	44,12
21,0	55	UNI 19	1	537.2101	44,12
22,0	55	UNI 19	1	537.2201	50,19
23,0	55	UNI 19	1	537.2301	50,19
24,0	55	UNI 19	1	537.2401	53,08
25,0	55	UNI 19	1	537.2501	53,08
26,0	55	UNI 19	1	537.2601	56,04
27,0	55	UNI 19	1	537.2701	56,04
28,0	55	UNI 19	1	537.2801	60,98
29,0	55	UNI 19	1	537.2901	60,98
30,0	55	UNI 19	1	537.3001	64,06
31,0	55	UNI 19	1	537.3101	64,06
32,0	55	UNI 19	1	537.3201	68,59
33,0	55	UNI 19	1	537.3301	68,59
34,0	55	UNI 19	1	537.3401	73,08
35,0	55	UNI 19	1	537.3501	73,08
36,0	55	UNI 19	1	537.3601	82,72

d ₁	T _{max}	A ₁	pcs/PU	Item no.	€ / PU
37,0	55	UNI 19	1	537.3701	86,03
38,0	55	UNI 19	1	537.3801	91,31
39,0	55	UNI 19	1	537.3901	96,87
40,0	55	UNI 19	1	537.4001	99,93
41,0	55	UNI 19	1	537.4101	99,93
42,0	55	UNI 19	1	537.4201	108,11
43,0	55	UNI 19	1	537.4301	108,11
44,0	55	UNI 19	1	537.4401	118,73
45,0	55	UNI 19	1	537.4501	118,73
46,0	55	UNI 19	1	537.4601	127,59
47,0	55	UNI 19	1	537.4701	127,70
48,0	55	UNI 19	1	537.4801	134,76
49,0	55	UNI 19	1	537.4901	134,76
50,0	55	UNI 19	1	537.5001	152,06
51,0	55	UNI 19	1	537.5101	161,29
52,0	55	UNI 19	1	537.5201	159,27
53,0	55	UNI 19	1	537.5301	174,38
54,0	55	UNI 19	1	537.5401	180,08
55,0	55	UNI 19	1	537.5501	174,44
56,0	55	UNI 19	1	537.5601	190,66
57,0	55	UNI 19	1	537.5701	195,27
58,0	55	UNI 19	1	537.5801	200,60
59,0	55	UNI 19	1	537.5901	205,18
60,0	55	UNI 19	1	537.6001	198,98

545

Ejector pin 55mm

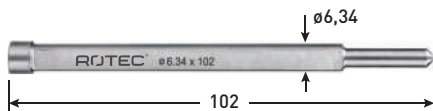

Dimensions (mm)	d (min-max)	pcs/PU	Item no.	€ / PU
ø6,34 x 102mm	ø12 - 60mm	1	545.0031	7,60

539

HSS-XE Annular cutter GOLD-LINE 40mm (FEIN/QUICK-IN)

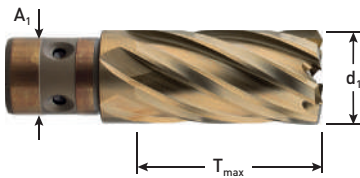

Execution: GOLD-LINE annular cutter, made of high grade alloyed HSS-XE, fully ground execution, Gold-Tech coated. Stage hardened with very hard (up to 68 HRC) and wear resistant cutting edges while maintaining a tough body to allow high-torque applications. Excellent chip evacuation and self-centering properties.

FEIN / QUICK-IN shank 18mm.

Application: For drilling holes in all types of steels up to 900 N/mm² as well as stainless steel, copper, aluminium and plastics.
Material groups : 1.1 - 1.4 / 2.1 - 2.2 / 3.1 - 3.2 / 4.1 - 4.12 / 5.1 / 5.3

d ₁	T _{max}	A ₁	pcs/PU	Item no.	€ / PU
12,0	40	QUI 18	1	539.1200	32,54
13,0	40	QUI 18	1	539.1300	32,54
14,0	40	QUI 18	1	539.1400	33,04
15,0	40	QUI 18	1	539.1500	33,04
16,0	40	QUI 18	1	539.1600	33,74
17,0	40	QUI 18	1	539.1700	33,74
18,0	40	QUI 18	1	539.1800	35,53
19,0	40	QUI 18	1	539.1900	35,53
20,0	40	QUI 18	1	539.2000	39,09
21,0	40	QUI 18	1	539.2100	39,09
22,0	40	QUI 18	1	539.2200	45,07
23,0	40	QUI 18	1	539.2300	45,14
24,0	40	QUI 18	1	539.2400	46,69
25,0	40	QUI 18	1	539.2500	46,69
26,0	40	QUI 18	1	539.2600	49,65

d ₁	T _{max}	A ₁	pcs/PU	Item no.	€ / PU
27,0	40	QUI 18	1	539.2700	49,83
28,0	40	QUI 18	1	539.2800	53,40
29,0	40	QUI 18	1	539.2900	53,40
30,0	40	QUI 18	1	539.3000	55,92
31,0	40	QUI 18	1	539.3100	59,30
32,0	40	QUI 18	1	539.3200	58,78
33,0	40	QUI 18	1	539.3300	58,79
34,0	40	QUI 18	1	539.3400	61,81
35,0	40	QUI 18	1	539.3500	61,81
40,0	40	QUI 18	1	539.4000	81,77
45,0	40	QUI 18	1	539.4500	96,76
50,0	40	QUI 18	1	539.5000	117,03
55,0	40	QUI 18	1	539.5500	138,50
60,0	40	QUI 18	1	539.6000	161,77

545

Ejector pin 40mm

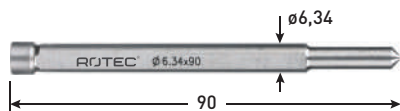

Dimensions (mm)	d (min-max)	pcs/PU	Item no.	€ / PU
ø6,34 x 90mm	ø12 - 17mm	1	545.0035	7,72

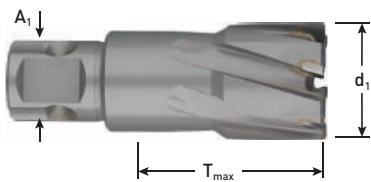

Execution: HARD-LINE Tungsten carbide tipped annular cutter made with a conical helix for a clean chip flow and the highest cutting abilities, even in difficult to cut materials. Tothing with pre-, intermediate-, and finish-cutting geometry which results in shatter-free, silent and easy cutting with excellent tool life.

Universal 19mm (¾") shank with WELDON and NITTO connections.

Application: Maximum cutting capacities in all kinds of steel up to 1.400 N/mm² as well as excellent results when drilling in hardened steels up to 40 HRC, all sorts of stainless steel, difficult to cut alloys (Hardox/ Inconel/Titanium) and non-ferrous metals (aluminium, copper, brass, etc.)

Materialgroups : 1.1 - 1.6 / 2.1 - 2.3 / 3.1 - 3.3 / 4.1 - 4.13 / 5.1 - 5.4

d ₁	T _{max}	A ₁	pcs/PU	Item no.	€/ PU
12,0	40	UNI 19	1	546.0120	56,83
13,0	40	UNI 19	1	546.0130	56,83
14,0	40	UNI 19	1	546.0140	60,13
15,0	40	UNI 19	1	546.0150	60,13
16,0	40	UNI 19	1	546.0160	60,13
17,0	40	UNI 19	1	546.0170	60,13
18,0	40	UNI 19	1	546.0180	60,13
19,0	40	UNI 19	1	546.0190	60,13
20,0	40	UNI 19	1	546.0200	60,13
21,0	40	UNI 19	1	546.0210	61,85
22,0	40	UNI 19	1	546.0220	61,85
23,0	40	UNI 19	1	546.0230	64,94
24,0	40	UNI 19	1	546.0240	61,85
25,0	40	UNI 19	1	546.0250	61,85
26,0	40	UNI 19	1	546.0260	65,25
27,0	40	UNI 19	1	546.0270	65,34
28,0	40	UNI 19	1	546.0280	65,34
29,0	40	UNI 19	1	546.0290	65,42
30,0	40	UNI 19	1	546.0300	65,34
31,0	40	UNI 19	1	546.0310	77,18
32,0	40	UNI 19	1	546.0320	77,18
33,0	40	UNI 19	1	546.0330	77,18
34,0	40	UNI 19	1	546.0340	77,18
35,0	40	UNI 19	1	546.0350	77,18
36,0	40	UNI 19	1	546.0360	88,24

d ₁	T _{max}	A ₁	pcs/PU	Item no.	€/ PU
37,0	40	UNI 19	1	546.0370	88,35
38,0	40	UNI 19	1	546.0380	88,35
39,0	40	UNI 19	1	546.0390	88,35
40,0	40	UNI 19	1	546.0400	88,35
41,0	40	UNI 19	1	546.0410	106,76
42,0	40	UNI 19	1	546.0420	106,76
43,0	40	UNI 19	1	546.0430	106,76
44,0	40	UNI 19	1	546.0440	106,65
45,0	40	UNI 19	1	546.0450	106,65
46,0	40	UNI 19	1	546.0460	114,31
47,0	40	UNI 19	1	546.0470	114,31
48,0	40	UNI 19	1	546.0480	114,31
49,0	40	UNI 19	1	546.0490	114,31
50,0	40	UNI 19	1	546.0500	121,04
51,0	40	UNI 19	1	546.0510	131,34
52,0	40	UNI 19	1	546.0520	134,65
53,0	40	UNI 19	1	546.0530	138,67
54,0	40	UNI 19	1	546.0540	143,23
55,0	40	UNI 19	1	546.0550	146,16
56,0	40	UNI 19	1	546.0560	151,57
57,0	40	UNI 19	1	546.0570	154,96
58,0	40	UNI 19	1	546.0580	158,04
59,0	40	UNI 19	1	546.0590	160,64
60,0	40	UNI 19	1	546.0600	163,36
65,0	40	UNI 19	1	546.0650	192,77

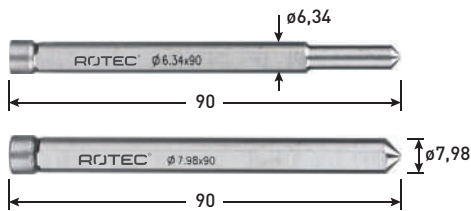

Dimensions (mm)	d (min-max)	pcs/PU	Item no.	€/ PU
ø6,34 x 90mm	ø12 - 17mm	1	545.0035	7,72
ø7,98 x 90mm	ø18 - 65mm	1	545.0051	7,49

546

TCT Annular cutter HARD-LINE 55mm (UNI)

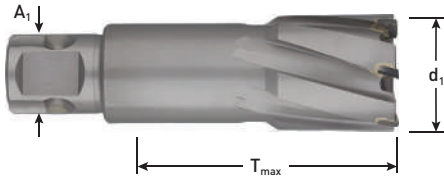

Execution: HARD-LINE Tungsten carbide tipped annular cutter made with a conical helix for a clean chip flow and the highest cutting abilities, even in difficult to cut materials. Tothing with pre-, intermediate-, and finish-cutting geometry which results in shatter-free, silent and easy cutting with excellent tool life.

Universal 19mm (¾") shank with WELDON and NITTO connections.

Application: Maximum cutting capacities in all kinds of steel up to 1.400 N/mm² as well as excellent results when drilling in hardened steels up to 40 HRC, all sorts of stainless steel, difficult to cut alloys (Hardox/ Inconel/Titanium) and non-ferrous metals (aluminium, copper, brass, etc.)

Materialgroups : 1.1 - 1.6 / 2.1 - 2.3 / 3.1 - 3.3 / 4.1 - 4.13 / 5.1 - 5.4

d ₁	T _{max}	A ₁	pcs/PU	Item no.	€/ PU
12,0	55	UNI 19	1	546.0121	66,54
13,0	55	UNI 19	1	546.0131	70,02
14,0	55	UNI 19	1	546.0141	66,54
15,0	55	UNI 19	1	546.0151	66,54
16,0	55	UNI 19	1	546.0161	66,54
17,0	55	UNI 19	1	546.0171	66,54
18,0	55	UNI 19	1	546.0181	66,54
19,0	55	UNI 19	1	546.0191	66,54
20,0	55	UNI 19	1	546.0201	66,54
21,0	55	UNI 19	1	546.0211	70,49
22,0	55	UNI 19	1	546.0221	68,59
23,0	55	UNI 19	1	546.0231	68,59
24,0	55	UNI 19	1	546.0241	68,59
25,0	55	UNI 19	1	546.0251	68,59
26,0	55	UNI 19	1	546.0261	72,67
27,0	55	UNI 19	1	546.0271	72,73
28,0	55	UNI 19	1	546.0281	72,73
29,0	55	UNI 19	1	546.0291	72,73
30,0	55	UNI 19	1	546.0301	72,73
31,0	55	UNI 19	1	546.0311	85,51
32,0	55	UNI 19	1	546.0321	85,51
33,0	55	UNI 19	1	546.0331	85,51
34,0	55	UNI 19	1	546.0341	85,51
35,0	55	UNI 19	1	546.0351	85,51
36,0	55	UNI 19	1	546.0361	97,62

d ₁	T _{max}	A ₁	pcs/PU	Item no.	€/ PU
37,0	55	UNI 19	1	546.0371	97,78
38,0	55	UNI 19	1	546.0381	97,78
39,0	55	UNI 19	1	546.0391	97,78
40,0	55	UNI 19	1	546.0401	97,78
41,0	55	UNI 19	1	546.0411	117,99
42,0	55	UNI 19	1	546.0421	117,99
43,0	55	UNI 19	1	546.0431	117,99
44,0	55	UNI 19	1	546.0441	117,99
45,0	55	UNI 19	1	546.0451	117,99
46,0	55	UNI 19	1	546.0461	126,85
47,0	55	UNI 19	1	546.0471	126,85
48,0	55	UNI 19	1	546.0481	126,85
49,0	55	UNI 19	1	546.0491	126,85
50,0	55	UNI 19	1	546.0501	134,24
51,0	55	UNI 19	1	546.0511	145,66
52,0	55	UNI 19	1	546.0521	149,26
53,0	55	UNI 19	1	546.0531	153,59
54,0	55	UNI 19	1	546.0541	158,70
55,0	55	UNI 19	1	546.0551	162,11
56,0	55	UNI 19	1	546.0561	168,08
57,0	55	UNI 19	1	546.0571	172,10
58,0	55	UNI 19	1	546.0581	175,27
59,0	55	UNI 19	1	546.0591	178,11
60,0	55	UNI 19	1	546.0601	181,19
65,0	55	UNI 19	1	546.0651	206,40

545

Ejector pin 55mm

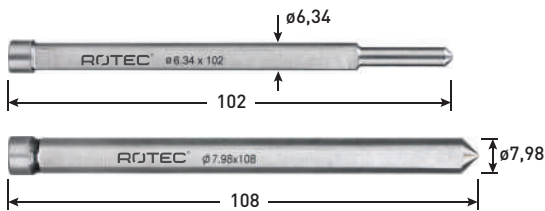

Dimensions (mm)	d (min-max)	pcs/PU	Item no.	€/ PU
ø6,34 x 102mm	ø12 - 60mm	1	545.0031	7,60
ø7,98 x 108mm	ø18 - 65mm	1	545.0053	11,69

546

TCT Annular cutter HARD-LINE 80mm (UNI)

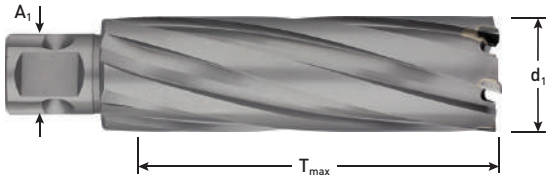

Execution: HARD-LINE Tungsten carbide tipped annular cutter made with a conical helix for a clean chip flow and the highest cutting abilities, even in difficult to cut materials. Tothing with pre-, intermediate-, and finish-cutting geometry which results in shatter-free, silent and easy cutting with excellent tool life.

Universal 19mm (¾") shank with WELDON and NITTO connections.

Application: Maximum cutting capacities in all kinds of steel up to 1,400 N/mm² as well as excellent results when drilling in hardened steels up to 40 HRC, all sorts of stainless steel, difficult to cut alloys (Hardox/ Inconel/Titanium) and non-ferrous metals (aluminium, copper, brass, etc.)
Materiaalgroepen : 1.1 - 1.6 / 2.1 - 2.3 / 3.1 - 3.3 / 4.1 - 4.13 / 5.1 - 5.4

d ₁	T _{max}	A ₁	pcs/PU	Item no.	€ / PU
18,0	80	UNI 19	1	546.0182	109,81
19,0	80	UNI 19	1	546.0192	109,94
20,0	80	UNI 19	1	546.0202	109,81
21,0	80	UNI 19	1	546.0212	109,94
22,0	80	UNI 19	1	546.0222	109,81
23,0	80	UNI 19	1	546.0232	109,94
24,0	80	UNI 19	1	546.0242	109,81
25,0	80	UNI 19	1	546.0252	109,81
26,0	80	UNI 19	1	546.0262	119,69
27,0	80	UNI 19	1	546.0272	119,69
28,0	80	UNI 19	1	546.0282	119,69
29,0	80	UNI 19	1	546.0292	119,69
30,0	80	UNI 19	1	546.0302	119,69
31,0	80	UNI 19	1	546.0312	144,56
32,0	80	UNI 19	1	546.0322	144,56
33,0	80	UNI 19	1	546.0332	144,70
34,0	80	UNI 19	1	546.0342	144,70
35,0	80	UNI 19	1	546.0352	144,56
36,0	80	UNI 19	1	546.0362	165,11
37,0	80	UNI 19	1	546.0372	164,90
38,0	80	UNI 19	1	546.0382	165,11
39,0	80	UNI 19	1	546.0392	164,90

d ₁	T _{max}	A ₁	pcs/PU	Item no.	€ / PU
40,0	80	UNI 19	1	546.0402	164,90
41,0	80	UNI 19	1	546.0412	199,58
42,0	80	UNI 19	1	546.0422	199,58
43,0	80	UNI 19	1	546.0432	199,58
44,0	80	UNI 19	1	546.0442	199,58
45,0	80	UNI 19	1	546.0452	199,31
46,0	80	UNI 19	1	546.0462	227,61
47,0	80	UNI 19	1	546.0472	227,61
48,0	80	UNI 19	1	546.0482	227,61
49,0	80	UNI 19	1	546.0492	227,61
50,0	80	UNI 19	1	546.0502	227,36
51,0	80	UNI 19	1	546.0512	225,14
52,0	80	UNI 19	1	546.0522	230,76
53,0	80	UNI 19	1	546.0532	235,60
54,0	80	UNI 19	1	546.0542	241,50
55,0	80	UNI 19	1	546.0552	246,83
56,0	80	UNI 19	1	546.0562	253,25
57,0	80	UNI 19	1	546.0572	259,18
58,0	80	UNI 19	1	546.0582	264,65
59,0	80	UNI 19	1	546.0592	269,67
60,0	80	UNI 19	1	546.0602	276,15

545

Ejector pin 80mm



Dimensions (mm)	d (min-max)	pcs/PU	Item no.	€ / PU
ø7,98 x 130mm	ø18 - 60mm	1	545.0034	12,96

546

TCT Annular cutter HARD-LINE 110mm (UNI)

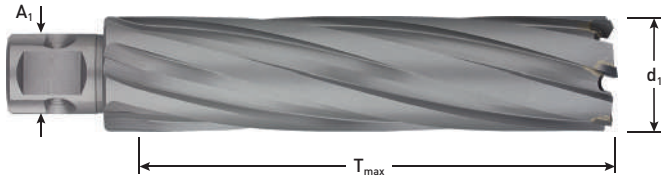

Execution: HARD-LINE Tungsten carbide tipped annular cutter made with a conical helix for a clean chip flow and the highest cutting abilities, even in difficult to cut materials. Tothing with pre-, intermediate-, and finish-cutting geometry which results in shatter-free, silent and easy cutting with excellent tool life.

Universal 19mm (¾") shank with WELDON and NITTO connections.

Application: Maximum cutting capacities in all kinds of steel up to 1.400 N/mm² as well as excellent results when drilling in hardened steels up to 40 HRC, all sorts of stainless steel, difficult to cut alloys (Hardox/Inconel/Titanium) and non-ferrous metals (aluminium, copper, brass, etc.)

Materialgroups : 1.1 - 1.6 / 2.1 - 2.3 / 3.1 - 3.3 / 4.1 - 4.13 / 5.1 - 5.4

d ₁	T _{max}	A ₁	pcs/PU	Item no.	€ / PU
18,0	110	UNI 19	1	546.0183	139,69
19,0	110	UNI 19	1	546.0193	139,69
20,0	110	UNI 19	1	546.0203	139,69
21,0	110	UNI 19	1	546.0213	139,69
22,0	110	UNI 19	1	546.0223	139,69
23,0	110	UNI 19	1	546.0233	139,69
24,0	110	UNI 19	1	546.0243	139,69
25,0	110	UNI 19	1	546.0253	139,69
26,0	110	UNI 19	1	546.0263	152,29
27,0	110	UNI 19	1	546.0273	152,29
28,0	110	UNI 19	1	546.0283	152,29
29,0	110	UNI 19	1	546.0293	152,29
30,0	110	UNI 19	1	546.0303	152,29
31,0	110	UNI 19	1	546.0313	183,47
32,0	110	UNI 19	1	546.0323	183,47
33,0	110	UNI 19	1	546.0333	183,47
34,0	110	UNI 19	1	546.0343	183,47
35,0	110	UNI 19	1	546.0353	183,47
36,0	110	UNI 19	1	546.0363	210,15
37,0	110	UNI 19	1	546.0373	210,15
38,0	110	UNI 19	1	546.0383	210,15
39,0	110	UNI 19	1	546.0393	210,15

d ₁	T _{max}	A ₁	pcs/PU	Item no.	€ / PU
40,0	110	UNI 19	1	546.0403	210,15
41,0	110	UNI 19	1	546.0413	253,65
42,0	110	UNI 19	1	546.0423	253,65
43,0	110	UNI 19	1	546.0433	253,65
44,0	110	UNI 19	1	546.0443	253,65
45,0	110	UNI 19	1	546.0453	253,65
46,0	110	UNI 19	1	546.0463	288,92
47,0	110	UNI 19	1	546.0473	288,92
48,0	110	UNI 19	1	546.0483	288,92
49,0	110	UNI 19	1	546.0493	288,92
50,0	110	UNI 19	1	546.0503	288,92
51,0	110	UNI 19	1	546.0513	299,66
52,0	110	UNI 19	1	546.0523	309,89
53,0	110	UNI 19	1	546.0533	320,48
54,0	110	UNI 19	1	546.0543	330,63
55,0	110	UNI 19	1	546.0553	341,65
56,0	110	UNI 19	1	546.0563	352,15
57,0	110	UNI 19	1	546.0573	363,21
58,0	110	UNI 19	1	546.0583	368,56
59,0	110	UNI 19	1	546.0593	375,27
60,0	110	UNI 19	1	546.0603	382,41

545

Ejector pin 110mm

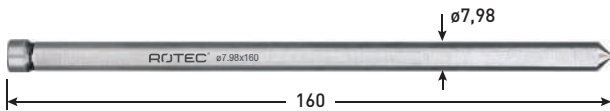

Dimensions (mm)	d (min-max)	pcs/PU	Item no.	€ / PU
ø7,98 x 160mm	ø18 - 60mm	1	545.0032	13,29

549

TCT Annular cutter HARD-LINE 40mm (FEIN/QUICK-IN)



Execution: HARD-LINE Tungsten carbide tipped annular cutter made with a conical helix for a clean chip flow and the highest cutting abilities, even in difficult to cut materials. Tothing with pre-, intermediate-, and finish-cutting geometry which results in shatter-free, silent and easy cutting with excellent tool life.

FEIN / QUICK-IN shank 18mm.

Application: Maximum cutting capacities in all kinds of steel up to 1,400 N/mm² as well as excellent results when drilling in hardened steels up to 40 HRC, all sorts of stainless steel, difficult to cut alloys (Hardox/ Inconel/Titanium) and non-ferrous metals (aluminium, copper, brass, etc.)
Materialgroups : 1.1 - 1.6 / 2.1 - 2.3 / 3.1 - 3.3 / 4.1 - 4.13 / 5.1 - 5.4

d ₁	T _{max}	A ₁	pcs/PU	Item no.	€ / PU
12,0	40	QUI 18	1	549.1200	56,83
13,0	40	QUI 18	1	549.1300	56,83
14,0	40	QUI 18	1	549.1400	60,13
15,0	40	QUI 18	1	549.1500	60,13
16,0	40	QUI 18	1	549.1600	60,13
17,0	40	QUI 18	1	549.1700	60,13
18,0	40	QUI 18	1	549.1800	60,13
19,0	40	QUI 18	1	549.1900	60,13
20,0	40	QUI 18	1	549.2000	60,13
21,0	40	QUI 18	1	549.2100	61,85
22,0	40	QUI 18	1	549.2200	61,85
23,0	40	QUI 18	1	549.2300	61,85
24,0	40	QUI 18	1	549.2400	61,85
25,0	40	QUI 18	1	549.2500	61,85
26,0	40	QUI 18	1	549.2600	65,25

d ₁	T _{max}	A ₁	pcs/PU	Item no.	€ / PU
27,0	40	QUI 18	1	549.2700	65,34
28,0	40	QUI 18	1	549.2800	65,34
29,0	40	QUI 18	1	549.2900	65,42
30,0	40	QUI 18	1	549.3000	65,34
31,0	40	QUI 18	1	549.3100	77,18
32,0	40	QUI 18	1	549.3200	77,18
33,0	40	QUI 18	1	549.3300	77,18
34,0	40	QUI 18	1	549.3400	77,18
35,0	40	QUI 18	1	549.3500	77,18
40,0	40	QUI 18	1	549.4000	88,35
45,0	40	QUI 18	1	549.4500	106,65
50,0	40	QUI 18	1	549.5000	121,04
55,0	40	QUI 18	1	549.5500	146,16
60,0	40	QUI 18	1	549.6000	163,36

545

Ejector pin 40mm

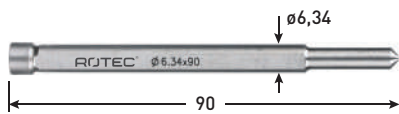

Dimensions (mm)	d (min-max)	pcs/PU	Item no.	€ / PU
ø6,34 x 90mm	ø12 - 17mm	1	545.0035	7,72
ø7,98 x 90mm	ø18 - 65mm	1	545.0051	7,49

538

HSS twisted drill bit (WLD)

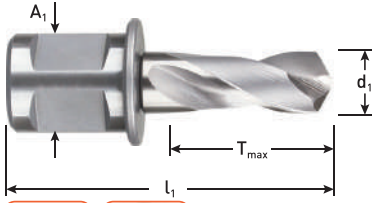

Execution: HSS drill bit, 3 fully CBN ground cutting edges and flutes for extremely stable drilling. Easy to regrind! Standard 19mm (¾") shank with WELDON connection.

Application: For magnetic core drills or drill presses with either WELDON-type spindle mount or Morse taper spindle mount in conjunction with an appropriate adapter. For drilling in construction steels, mild steels and alloyed steels.

d ₁	l ₁	T _{max}	A ₁	pcs/PU	Item no.	€ / PU
6,0	64	30	WLD 19	1	538.9006	45,28
8,0	64	30	WLD 19	1	538.9008	45,28
10,0	64	30	WLD 19	1	538.9010	47,10
12,0	64	30	WLD 19	1	538.9012	53,19

HSS Twisted drill bit set (WLD) in plastic case set SILVER-LINE 30mm (WLD), in plastic case



Execution: HSS drill bit, 3 fully CBN ground cutting edges and flutes for extremely stable drilling. Easy to regrind! Standard 19mm (¾") shank with WELDON connection.

Application: For magnetic core drills or drill presses with either WELDON-type spindle mount or Morse taper spindle mount in conjunction with an appropriate adapter. For drilling in construction steels, mild steels and alloyed steels.

Description	Type	Content	pcs/PU	Item no.	€ / PU
4 pc drill bit set, 30mm	538	1x ø6, 8, 10 en 12mm	1	538.9020	123,06

HSS Countersink (WLD)

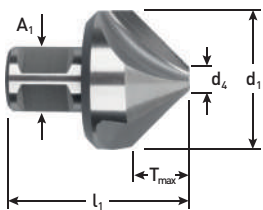

Execution: HSS countersink, 90°, CBN ground cutting edges and flutes for extremely stable countersinking/chamfering applications. Standard 19mm (¾") shank with WELDON connection.

Application: For magnetic core drills or drill presses with either WELDON-type spindle mount or Morse taper spindle mount in conjunction with an appropriate adapter. For drilling in construction steels, mild steels and alloyed steels.

d ₁	d ₄	l ₁	T _{max}	A ₁	pcs/PU	Item no.	€ / PU
25	4	43	10	WLD 19	1	538.9325	35,87
30	4	47	13	WLD 19	1	538.9330	45,14
40	7	52	16	WLD 19	1	538.9340	64,55
55	9	63	23	WLD 19	1	538.9355	120,28



M ₁	A ₂	pcs/PU	Item no.	€ / PU
MT 2	WLD 19	1	545.1004	76,60
MT 3	WLD 19	1	545.1006	82,22
MT 3	WLD 32	1	545.1009	70,70

Holder for annular cutters "Quick-Change"



M ₁	A ₂	pcs/PU	Item no.	€ / PU
MT 2	WLD 19	1	545.1011	199,41
MT 3	WLD 19	1	545.1012	205,08

Holder for annular cutters, with coolant ring

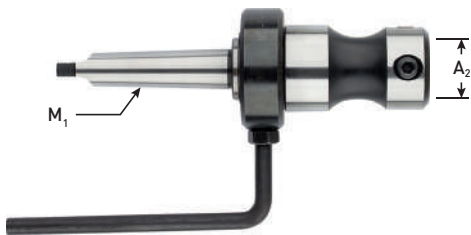

M ₁	A ₂	pcs/PU	Item no.	€ / PU
MT 2	WLD 19	1	545.1005	146,60
MT 3	WLD 19	1	545.1007	158,68
MT 3	WLD 32	1	545.1008	174,78
MT 4	WLD 32	1	545.1010	238,47

Holder for annular cutters "Quick-Change", with coolant ring



M ₁	A ₂	pcs/PU	Item no.	€ / PU
MT 2	WLD 19	1	545.1013	271,32
MT 3	WLD 19	1	545.1014	279,93

Adapter 1/2" x 20 UNF for drill chucks



Application: For mounting a drill chuck on a magnetic core drill with a fixed spindle with 3/4" Weldon (WLD 19) or Universal (UNI 19) interface.

A ₁	A ₂	pcs/PU	Item no.	€ / PU
WLD 19	1/2" x 20 UNF	1	545.1020	48,05
UNI 19	1/2" x 20 UNF	1	545.1021	46,45

Adapter

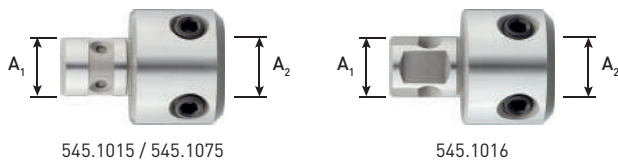

Application: Longer ejection pins are required!

SILVER-LINE or GOLD-LINE annular cutters
with max. drilling depth 30mm > 545.0031 (instead of 545.0030)

SILVER-LINE or GOLD-LINE annular cutters
with max. drilling depth 55mm > 545.0033 (instead of 545.0031)

HARD-LINE annular cutters
with max. drilling depth 40mm > 545.0055 (instead of 545.0035)

A ₁	A ₂	pcs/PU	Item no.	€ / PU
QUI 18	UNI 19	1	545.1015	32,47
QUI 18	WLD 19	1	545.1075	32,47
UNI 19	WLD 19	1	545.1016	30,26

Ejector pin $\varnothing 6,34 \times 102$

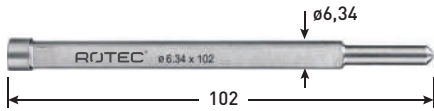

Application: Use this ejector pin with adapter 545.1015 or 545.1016 in combination with following types of cutters:

SILVER-LINE or GOLD-LINE annular cutters
With a max. drilling depth of 30mm.

Dimensions (mm)	d (min-max)	pcs/PU	Item no.	€ / PU
$\varnothing 6,34 \times 102\text{mm}$	$\varnothing 12 - 60\text{mm}$	1	545.0031	7,60

Ejector pin $\varnothing 6,34 \times 130$

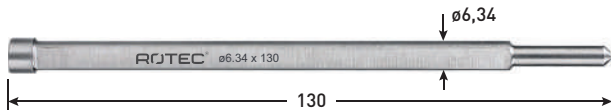

Application: Use this ejector pin with adapter 545.1015 or 545.1016 in combination with following types of cutters:

SILVER-LINE or GOLD-LINE annular cutters
With a max. drilling depth of 55mm.

Dimensions (mm)	d (min-max)	pcs/PU	Item no.	€ / PU
$\varnothing 6,34 \times 130\text{mm}$	$\varnothing 12 - 60\text{mm}$	1	545.0033	8,52

Ejector pin $\varnothing 6,34 \times 116$

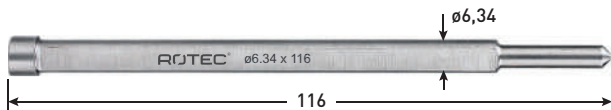

Application: Use this ejector pin with adapter 545.1015 or 545.1016 in combination with following types of cutters:

HARD-LINE annular cutters
With a max. drilling depth of 40mm.

Dimensions (mm)	d (min-max)	pcs/PU	Item no.	€ / PU
$\varnothing 6,34 \times 116\text{mm}$	$\varnothing 12 - 17\text{mm}$	1	545.0055	9,12



Technical specifications :

Motor / total power	900 Watt / 950 Watt
Voltage(s)	220-240 V @ 50-60 Hz
Spindle speed	775 rpm (idle) / 400 rpm (max. load)
Spindle rotation	right hand rotation only
Spindle mount	WELDON 19 (19,05mm)
Stroke length	90 mm
Machine L x W x H	275 x 190 x 293-383 mm
Magn. foot L x W x H	160 x 80 x 37 mm
Magnetic adhesion	1.200 kg / 11.772 N
Weight	8,5 kg
Working capacity :	
Annular cutters	ø12 - 30 mm
Drill bits	ø1 - 13 mm
Countersinking	ø10 - 35 mm

Description	Packaging	pcs/PU	Content	Item no.	€ / PU
Magnetic core drilling machine RTC 30 + case	Case	1	1x RTC 30 magnetic core drill 1x safety cap 3x levers 1x allen key - 2,5 mm 1x allen key - 4 mm 1x allen key - 5 mm 1x lubricating- and cooling system 1x safety chain 1x bottle (200 ml) for coolant 1x user manual 1x hearing protection 1x safety goggles 1x safety gloves	906.0030	591,25

Magnetic core drill RTC 32



Technical specifications :

Motor / total power	1.000 Watt / 1.050 Watt
Voltage(s)	220-240 V @ 50-60 Hz
Spindle speed	775 rpm (idle) / 440 rpm (max. load)
Spindle rotation	right hand rotation only
Spindle mount	WELDON 19 (19,05mm)
Stroke length	150 mm
Machine L x W x H	320 x 210 x 370-512 mm
Magn. foot L x W x H	160 x 80 x 42 mm
Magnetic adhesion	1.500 kg / 14.715 N
Weight	11 kg
Working capacity :	
Annular cutters	ø12 - 32 mm
Drill bits	ø1 - 13 mm
Countersinking	ø10 - 40 mm

Description	Packaging	pcs/PU	Content	Item no.	€ / PU
Magnetic core drilling machine RTC 32 + case	Case	1	1x RTC 32 magnetic core drill 1x safety cap 3x levers 1x allen key - 2,5 mm 1x allen key - 4 mm 1x allen key - 5 mm 1x lubricating- and cooling system 1x safety chain 1x bottle (200 ml) for coolant 1x user manual 1x hearing protection 1x safety goggles 1x safety gloves	906.0032	671,88

Magnetic core drill RTC 50 R/L



Technical specifications :

Motor / total power	1.250 Watt / 1.375 Watt
Voltage(s)	220-240 V @ 50-60 Hz
Spindle speeds	(I) 100 - 280 rpm (idle) 250 rpm (max. load) (II) 185 - 530 rpm (idle) 460 rpm (max. load)
Spindle rotation	right and left hand rotation
Spindle mount	Morse taper 2 (MT 2)
Stroke length	170 mm
Machine L x W x H	320 x 210 x 385-540 mm
Magn. foot L x W x H	170 x 85 x 48 mm
Magnetic adhesion	1.850 kg / 18.150 N
Weight	13,5 kg

Working capacity :

Annular cutters	ø12 - 50 mm
Drill bits	ø1 - 23 mm
Tapping	M3 - M20
Countersinking	ø10 - 55 mm

Description	Packaging	pcs/PU	Content	Item no.	€ / PU
Magnetic core drilling machine RTC 50 R/L + case	Case	1	1x RTC 50 R/L magnetic core drill 1x safety cap 3x levers 1x allen key - 2,5 mm 1x allen key - 3 mm 1x allen key - 4 mm 1x allen key - 5 mm 1x lubricating- and cooling system 1x safety chain 1x bottle (200 ml) for coolant 1x adapter w/coolant ring from MT 2 to WELDON 19 (3/4") 1x drill drift MT 2 1x user manual 1x hearing protection 1x safety goggles 1x safety gloves	906.0050	1.101,88

Magnetic core drill RTC 100 R/L



Technical specifications :

Motor / total power	1.900 Watt / 2.050 Watt
Voltage(s)	220-240 V @ 50-60 Hz 110-120 V @ 60 Hz
Spindle speeds	(I) 42 - 110 rpm (idle) 85 rpm (max. load) (II) 64 - 190 rpm (idle) 152 rpm (max. load) (III) 140 - 400 rpm (idle) 270 rpm (max. load) (IV) 220 - 620 rpm (idle) 480 rpm (max. load)
Spindle rotation	right and left hand rotation
Spindle mount	Morse taper 3 (MT 3)
Stroke length	260 mm
Machine L x W x H	365 x 310 x 510-710 mm
Magn. foot L x W x H	220 x 110 x 64 mm
Magnetic adhesion	3.000 kg / 29.400 N
Weight	28 kg

Working capacity :

Annular cutters	ø12 - 100 mm
Drill bits	ø1 - 32 mm
Tapping	M3 - M30
Countersinking	ø10 - 105 mm

Description	Packaging	pcs/PU	Content	Item no.	€ / PU
Magnetic core drilling machine RTC 100 R/L + trolley	Trolley	1	1x RTC 100 R/L magnetic core drill 1x safety cap 3x levers 1x allen key - 2,5 mm 1x allen key - 4 mm 1x allen key - 5 mm 1x lubricating- and cooling system 1x safety chain 1x bottle (200 ml) for coolant 1x adapter w/coolant ring from MT 3 to WELDON 19 (3/4") 1x drill drift MT 3 1x user manual 1x hearing protection 1x safety goggles 1x safety gloves	906.0100	1.531,88



Technical specifications :

Motor / total power	1.050 Watt / 1.100 Watt
Voltage(s)	220-240 V @ 50-60 Hz
Spindle speed	700 rpm (idle) / 400 rpm (max. load)
Spindle rotation	right hand rotation only
Spindle mount	WELDON 19 (19,05mm)
Stroke length	40 mm
Machine L x W x H	310 x 135 x 165 mm
Magn. foot L x W x H	160 x 80 x 37 mm
Magnetic adhesion	1.200 kg / 11.772 N
Weight	10,3 kg
tab>	
u>Working capacity :	
Annular cutters	ø12 - 36 mm
Drill bits	ø1 - 14 mm
Countersinking	ø10 - 40 mm

Description	Packaging	pcs/PU	Content	Item no.	€ / PU
Magnetic core drilling machine RTC 36 + case	Case	1	1x RTC 36 magnetic core drill 1x lubricating- and cooling system 1x bottle coolant oil (200 ml) 1x safety gloves 1x safety belt 1x safety goggles 1x hearing protection 1x allen key 2x thumb screws 1x safety cap 1x user manual	906.0036	975,00

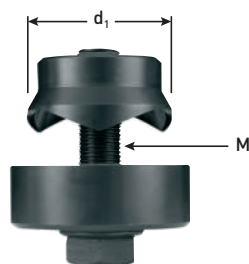

Execution: Steel hole punchers for hand use, 3 point cut lead, without and with ball-bearing (BB).

Application: For punching holes in steel (up to 3mm) and stainless steel (up to 1mm).

d ₁	MF(F) / PG	M	BB	pcs/PU	Item no.	€ / PU
12,7	M12/PG 7	MF 8	-	1	590.1270	43,79
15,2	PG 9	MF 10	-	1	590.1520	43,79
15,2	PG 9	MF 10	BB	1	590.1521	74,56
16,0	-	MF 10	-	1	590.1600	43,79
16,0	-	MF 10	BB	1	590.1601	74,56
16,5	M16	MF 10	-	1	590.1650	45,83
16,5	M16	MF 10	BB	1	590.1651	76,92
18,6	PG 11	MF 10	-	1	590.1860	49,09
18,6	PG 11	MF 10	BB	1	590.1861	80,18
20,4	M20/PG 13,5	MF 10	-	1	590.2040	49,09
20,4	M20/PG 13,5	MF 10	BB	1	590.2041	80,18
22,5	PG 16	MF 10	-	1	590.2250	53,62
22,5	PG 16	MF 10	BB	1	590.2251	84,63
25,0	-	MF 10	-	1	590.2500	58,91
25,0	-	MF 10	BB	1	590.2501	89,67
25,4	M25	MF 10	-	1	590.2540	58,91
25,4	M25	MF 10	BB	1	590.2541	89,67
28,3	PG 21	MF 12	-	1	590.2830	58,91
28,3	PG 21	MF 12	BB	1	590.2831	89,67
32,0	-	MF 12	-	1	590.3200	65,34
32,0	-	MF 12	BB	1	590.3201	96,38

d ₁	MF(F) / PG	M	BB	pcs/PU	Item no.	€ / PU
32,5	M32/PG	MF 12	-	1	590.3250	75,32
32,5	M32	MF 12	BB	1	590.3251	106,25
35,0	-	MF 12	-	1	590.3500	75,32
35,0	-	MF 12	BB	1	590.3501	106,25
37,0	PG 29	MF 12	-	1	590.3700	75,32
37,0	PG 29	MF 12	BB	1	590.3701	106,25
38,0	-	MF 12	-	1	590.3800	75,32
38,0	-	MF 12	BB	1	590.3801	106,25
40,5	M40	MF 16	-	1	590.4050	103,13
40,5	M40	MF 16	BB	1	590.4051	141,26
47,0	PG 36	MF 16	-	1	590.4700	122,47
47,0	PG 36	MF 16	BB	1	590.4701	160,67
50,5	M50	MF 16	-	1	590.5050	147,41
50,5	M50	MF 16	BB	1	590.5051	194,07
54,0	PG 42	MF 16	-	1	590.5400	159,58
54,0	PG 42	MF 16	BB	1	590.5401	206,61
60,0	PG 48	MF 16	-	1	590.6000	197,33
60,0	PG 48	MF 16	BB	1	590.6001	244,37
63,5	M63	MF 16	-	1	590.6350	226,89
63,5	M63	MF 16	BB	1	590.6351	273,93

Drawbolt

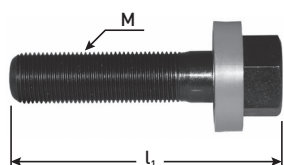

Execution: Draw bolts for hole punchers for hand use. "BB" means draw bolts with ball-bearing.

M	l ₁	Class	BB	pcs/PU	Item no.	€ / PU
MF 8 x 1,0	40	10.9	-	1	590.9005	1,96
MF10 x 1,0	45	12.9	-	1	590.9010	3,07
MF12 x 1,5	55	12.9	-	1	590.9015	3,68
MF16 x 1,5	60	12.9	-	1	590.9020	5,03
MF10 x 1,0	50	12.9	BB	1	590.9025	34,02
MF12 x 1,5	60	12.9	BB	1	590.9030	41,77
MF16 x 1,5	70	12.9	BB	1	590.9035	50,99

591

PREMIUM Hole puncher, with split

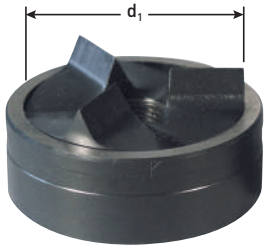

Execution: Premium type steel hole punchers with split for hand and hydraulic use. Greasing the drawbolt extends tool life and avoids tool seizure.

Application: For punching holes in steel (up to 3mm) and stainless steel (up to 1 mm).

d ₁	MF(F) / PG	Drawbolt	Drawbolt (hydr.)	pcs/PU	Item no.	€ / PU
15,2	PG9	9,5 x 50,0	19,0 x 9,5	1	591.1520	65,40
16,2 *	M16	9,5 x 50,0	19,0 x 9,5	1	591.1620	66,61
20,4 *	M20/PG13	9,5 x 50,0	19,0 x 9,5	1	591.2040	66,61
32,5 *	M32	19,0 x 55,0	19,0	1	591.3250	94,13

* Phase-out item, available until stock has depleted

Drawbolt (for hole punchers with split)



Application: ø6,0 : for use on mild steel sheets up to 1.5mm in thickness
 ø9,5 : for use on mild steel sheets up to 2.0mm in thickness
 ø19,0 : for use on mild steel sheets up to 3.0mm in thickness

Drawbolt	d (min-max)	BB	pcs/PU	Item no.	€ / PU
6,0 x 40,0 *	ø12,5	BB	1	591.9010	20,81
9,5 x 50,0 *	ø15,2 - 30,5	BB	1	591.9020	20,79
19,0 x 55,0 *	ø32,5 - 37,0	BB	1	591.9030	47,68

* Phase-out item, available until stock has depleted

Drawbolt (hydraulic)



Drawbolt (hydr.)	d (min-max)	pcs/PU	Item no.	€ / PU
19,0 x 9,5 *	ø15,2 - 30,5	1	591.9550	57,58

* Phase-out item, available until stock has depleted

592

Hole puncher, OPTI-LINE



OPTI



Execution: Steel hole punchers for hand use , 3 point cut lead, with ball-bearing (BB).

Application: For punching holes in steel (up to 3mm) and stainless steel (up to 1mm).

d ₁	MF(F) / PG	M	BB	pcs/PU	Item no.	€ / PU
32,5	M32/PG	MF 12	BB	1	592.3250	46,95
35,0	-	MF 12	BB	1	592.3500	49,85