

ROTEC®

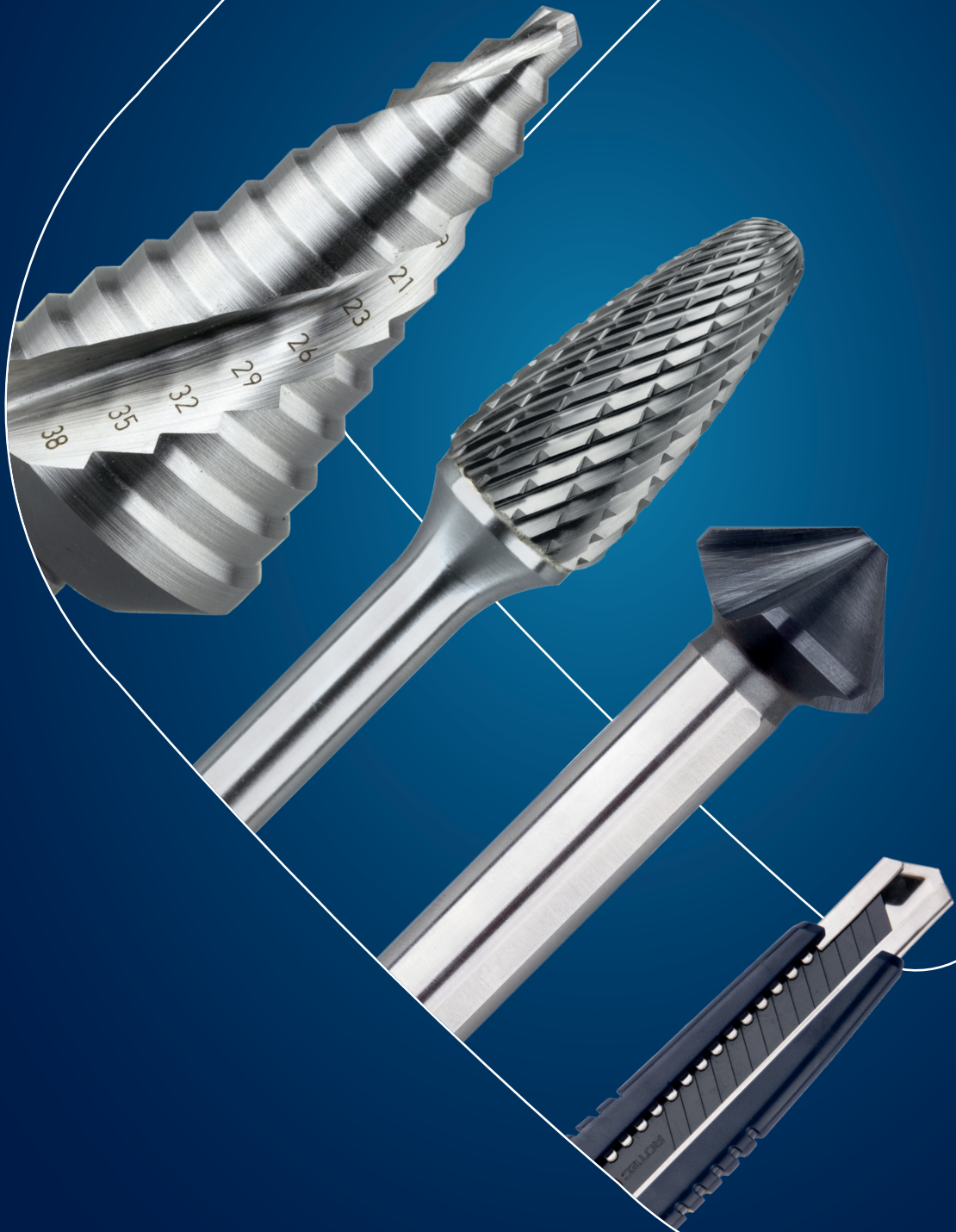

Countersinks,
deburrers and cutting

SPINDLE SPEEDS FOR HSS COUNTERSINKS

Material	Steel < 700 N/mm ²	Steel > 700 N/mm ²	Alloyed steel (stainless) < 1.000 N/mm ²	Cast iron < 250 HB	Cast iron > 250 HB	CuZn-alloys (brittle)	CuZn-alloys (soft)	Aluminium alloys <11% Si	Plastics	Duroplast (Fibre reinforced plastic)
Vc [m/min]	20	15	10	10	8	40	20	20	15	10
Diameter	RPM	RPM	RPM	RPM	RPM	RPM	RPM	RPM	RPM	RPM
ø4,3	1481	1110	740	740	592	2961	1481	1480	1110	740
ø5,0	1273	955	637	637	509	2546	1273	1273	955	637
ø5,3	1201	901	601	601	480	2402	1201	1201	901	601
ø5,8	1098	823	549	549	439	2195	1098	1098	823	549
ø6,0	1061	796	531	531	424	2122	1061	1061	796	531
ø6,3	1011	758	505	505	404	2021	1011	1011	758	505
ø7,0	909	682	455	455	364	1819	909	909	682	455
ø7,3	872	654	436	436	349	1744	872	872	654	436
ø8,0	796	597	398	398	318	1592	796	796	597	398
ø8,3	767	575	384	384	307	1534	767	767	575	384
ø9,4	677	508	339	339	271	1355	677	677	508	339
ø10,0	637	477	318	318	255	1273	637	637	477	318
ø10,4	612	459	306	306	245	1224	612	612	459	306
ø11,5	554	415	277	277	221	1107	554	554	415	277
ø12,0	531	398	265	265	212	1061	531	531	398	265
ø12,4	513	385	257	257	205	1027	513	513	385	257
ø12,5	509	382	255	255	204	1019	509	509	382	255
ø13,4	475	356	238	238	190	950	475	475	356	238
ø15,0	424	318	212	212	170	849	424	424	318	212
ø16,0	398	298	199	199	159	796	398	398	298	199
ø16,5	386	289	193	193	154	772	386	386	289	193
ø19,0	335	251	168	168	134	670	335	335	251	168
ø20,0	318	239	159	159	127	637	318	318	239	159
ø20,5	311	233	155	155	124	621	311	311	233	155
ø23,0	277	208	138	138	111	554	277	277	208	138
ø25,0	255	191	127	127	102	509	255	255	191	127
ø26,0	245	184	122	122	98	490	245	245	184	122
ø28,0	227	171	114	114	91	455	227	227	171	114
ø30,0	212	159	106	106	85	424	212	212	159	106
ø31,0	205	154	103	103	82	411	205	205	154	103

SPINDLE SPEEDS FOR ROTARY CARBIDE BURRS

Material	ø3mm	ø6mm	ø10mm	ø12mm	ø16mm
Steel	60.000 - 90.000	45.000 - 60.000	30.000 - 40.000	22.500 - 30.000	18.000 - 24.000
Steel, hardened	60.000 - 90.000	30.000 - 45.000	19.000 - 30.000	15.000 - 22.500	12.000 - 18.000
Stainless steel	60.000 - 90.000	30.000 - 45.000	19.000 - 30.000	15.000 - 22.500	12.000 - 18.000
Cast iron	45.000 - 90.000	22.500 - 60.000	15.000 - 40.000	11.000 - 30.000	9.000 - 24.000
Titanium	60.000 - 90.000	30.000 - 45.000	19.000 - 30.000	15.000 - 22.500	12.000 - 18.000
Nickel	60.000 - 90.000	30.000 - 45.000	19.000 - 30.000	15.000 - 22.500	12.000 - 18.000
Copper (alloys)	45.000 - 90.000	22.500 - 60.000	15.000 - 40.000	11.000 - 30.000	9.000 - 24.000
Aluminium (alloys)	30.000 - 90.000	15.000 - 70.000	10.000 - 50.000	7.000 - 38.000	6.000 - 30.000
Plastics	30.000 - 90.000	15.000 - 70.000	10.000 - 50.000	7.000 - 38.000	6.000 - 30.000
Cermets	60.000 - 90.000	30.000 - 45.000	19.000 - 30.000	15.000 - 22.500	12.000 - 18.000

400

HSS-G Countersink 90°

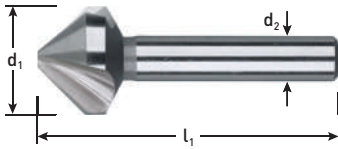

Execution: 90° HSS-G countersinks according to DIN 335-C, cylindrical shank, robust design with 3 flutes. Due to CBN precision ground geometry very sharp and precise cutting edges.

Application: Ideal for deburring or countersinking of the most commonly used materials. Best results with low rpms.
Material groups : 1.1 - 1.4 / 2.1 - 2.2 / 3.1 / 4.1 - 4.12 / 5.1 / 5.3

d ₁	l ₁	d ₂	Suitable for	pcs/PU	Item no.	€ / PU
4,3	40	4		1	400.0430	17,66
5,0	40	4		1	400.0500	17,66
5,3	40	4		1	400.0530	19,11
6,0	45	5		1	400.0600	19,11
6,3	45	5	M3	1	400.0630	17,86
7,0	50	6		1	400.0700	20,73
7,3	50	6		1	400.0730	20,73
8,0	50	6		1	400.0800	20,73
8,3	50	6	M4	1	400.0830	19,37
9,4	50	6		1	400.0940	22,39
10,0	50	6		1	400.1000	20,92
10,4	50	6	M5	1	400.1040	20,92

d ₁	l ₁	d ₂	Suitable for	pcs/PU	Item no.	€ / PU
11,5	56	8		1	400.1150	23,99
12,4	56	8	M6	1	400.1240	22,42
13,4	56	8		1	400.1340	25,51
15,0	60	10		1	400.1500	25,51
16,5	60	10	M8	1	400.1650	26,07
19,0	63	10		1	400.1900	32,02
20,5	63	10	M10	1	400.2050	33,65
25,0	67	10	M12	1	400.2500	41,06
28,0	71	12	M14	1	400.2800	59,90
31,0	71	12	M16	1	400.3100	58,17
40,0	80	15		1	400.4000	241,09

900

HSS-G Countersink set 90°, in ABS cassette



Execution: 90° HSS-G countersinks according to DIN 335-C, cylindrical shank, robust design with 3 flutes. Due to CBN precision ground geometry very sharp and precise cutting edges.

Application: Ideal for deburring or countersinking of the most commonly used materials. Best results with low rpms.
Material groups : 1.1 - 1.4 / 2.1 - 2.2 / 3.1 / 4.1 - 4.12 / 5.1 / 5.3

Description	Type	Content	pcs/PU	Item no.	€ / PU
6 piece set HSS-G countersinks	400	1x ø6,3 - 8,3 - 10,4 - 12,4 - 16,5 - 20,5mm	1	900.3010	136,60
7 piece set HSS-G countersinks	400	1x ø6,3 - 8,3 - 10,4 - 12,4 - 16,5 - 20,5 - 25,0mm	1	900.3011	188,65

400

HSS-G Countersink 90°, extra long

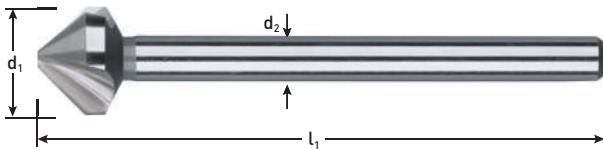

Execution: 90° HSS-G countersinks according to DIN 335-C, cylindrical shank, robust design with 3 flutes. Due to CBN precision ground geometry very sharp and precise cutting edges.

Application: Ideal for deburring or countersinking of the most commonly used materials. Best results with low rpms.
Material groups : 1.1 - 1.4 / 2.1 - 2.2 / 3.1 / 4.1 - 4.12 / 5.1 / 5.3

d ₁	l ₁	d ₂	Suitable for	pcs/PU	Item no.	€ / PU
6,3	85	5	M3	1	400.0631	39,32
8,3	85	6	M4	1	400.0831	40,97
10,4 *	88	6	M5	1	400.1041	47,57
12,4	108	8	M6	1	400.1241	50,39

d ₁	l ₁	d ₂	Suitable for	pcs/PU	Item no.	€ / PU
15,0	110	10		1	400.1501	71,20
16,5	112	10	M8	1	400.1651	71,60
20,5	115	10	M10	1	400.2051	81,42
25,0	118	10	M12	1	400.2501	98,56

* Phase-out item, available until stock has depleted

319 HSS-G Countersink 90°, 1/4"-bit shank

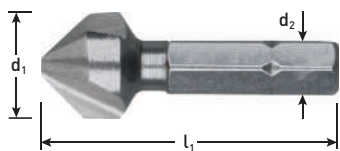

Execution: 90° HSS-G countersinks, 3 flutes, 1/4"-hexagon shank according to DIN 3126-C6.3.

Application: For deburring or countersinking of the most commonly used materials. Best results with low rpms. Ideal for (cordless) portable power tools. Material groups : 1.1 - 1.3 / 2.1 - 2.2 / 3.1 / 4.1 - 4.12

d ₁	l ₁	d ₂	M	pcs/PU	Item no.	€ / PU
6,3	31	1/4	M3	1	319.0630	19,19
8,3	31	1/4	M4	1	319.0830	19,19
10,4	34	1/4	M5	1	319.1040	20,49
12,4	35	1/4	M6	1	319.1240	21,91
16,5	40	1/4	M8	1	319.1650	26,03
20,5	41	1/4	M10	1	319.2050	32,53

900 HSS-G Countersink set 90°, 1/4"-bit shank, in plastic cassette



Execution: 90° HSS-G countersinks, 3 flutes, 1/4"-hexagon shank according to DIN 3126-C6.3.

Application: For deburring or countersinking of the most commonly used materials. Best results with low rpms. Ideal for (cordless) portable power tools. Material groups : 1.1 - 1.3 / 2.1 - 2.2 / 3.1 / 4.1 - 4.12

Description	Type	Content	pcs/PU	Item no.	€ / PU
6 piece set HSS-G countersinks (1/4" hex.)	319	1x ø6,3 - 8,3 - 10,4 - 12,4 - 16,5 - 20,5mm	1	900.2040	133,06

401 HSS Countersink 90°, MT-shank



Execution: 90° HSS-G countersinks according to DIN 335-D, morse-taper shank according to DIN 228-B, robust design with 3 flutes. Due to CBN precision ground geometry very sharp and precise cutting edges.

Application: Ideal for deburring or countersinking of the most commonly used materials. Best results with low rpms. Material groups : 1.1 - 1.4 / 2.1 - 2.2 / 3.1 / 4.1 - 4.12 / 5.1 / 5.3

d ₁	l ₁	M ₁	Suitable for	pcs/PU	Item no.	€ / PU
20,5	100	MT 2	M10	1	401.2050	98,94
25,0	106	MT 2	M12	1	401.2500	102,80
31,0	112	MT 2	M16	1	401.3100	117,88
37,0	118	MT 2	M20	1	401.3700	134,74
40,0	140	MT 3		1	401.4000	171,22
50,0	150	MT 3		1	401.5000	238,84
63,0	180	MT 4		1	401.6300	442,77
80,0	190	MT 4		1	401.8000	727,98

402 HSS Countersink 90°, ALU

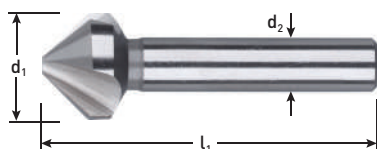

ALU

Execution: 90° HSS-G countersinks according to DIN 335-C, cylindrical shank, robust design with 3 flutes. Due to CBN precision ground geometry very sharp and precise cutting edges, specifically for aluminium.

Application: Ideal for deburring or countersinking of aluminium and similar soft materials. Best results with low rpms. Material groups : 1.1 - 1.3 / 4.1 - 4.12 / 5.1 / 5.3

d ₁	l ₁	d ₂	Suitable for	pcs/PU	Item no.	€ / PU
6,3	45	5	M3	1	402.0630	18,21
8,3	50	6	M4	1	402.0830	19,75
10,4	50	6	M5	1	402.1040	21,32
12,4	56	8	M6	1	402.1240	22,85
16,5	60	8	M8	1	402.1650	26,63
20,5	63	10	M10	1	402.2050	34,29
25,0	67	10	M12	1	402.2500	41,83

403

HSS-E Countersink 90°, INOX

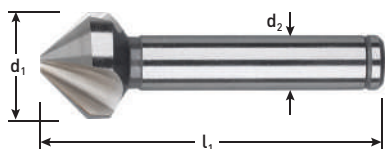

INOX

Execution: 90° HSS-E countersinks according to DIN 335-C, cylindrical shank, robust design with 3 flutes. Due to CBN precision ground geometry very sharp and precise cutting edges, specifically for difficult to cut materials.

Application: Ideal for deburring or countersinking of difficult to cut materials. Best results with low rpms!
Material groups : 1.1 - 1.5 / 2.1 - 2.3 / 3.1 - 3.3 / 5.1 - 5.4

d ₁	l ₁	d ₂	Suitable for	pcs/PU	Item no.	€ / PU
6,3	45	5	M3	1	403.0630	23,60
8,0	50	6		1	403.0800	25,12
8,3	50	6	M4	1	403.0830	25,88
10,0	50	6		1	403.1000	27,38
10,4	50	6	M5	1	403.1040	28,90
12,4	56	8	M6	1	403.1240	31,19
15,0	60	10		1	403.1500	34,29
16,5	60	8	M8	1	403.1650	35,68
20,5	63	10	M10	1	403.2050	51,00
25,0	67	10	M12	1	403.2500	66,23
31,0	71	12	M16	1	403.3100	98,09

900

HSS-E Countersink set 90°, INOX, in ABS cassette



INOX

Execution: 90° HSS-E countersinks according to DIN 335-C, cylindrical shank, robust design with 3 flutes. Due to CBN precision ground geometry very sharp and precise cutting edges, specifically for difficult to cut materials.

Application: Ideal for deburring or countersinking of difficult to cut materials. Best results with low rpms!
Material groups : 1.1 - 1.5 / 2.1 - 2.3 / 3.1 - 3.3 / 5.1 - 5.4

Description	Type	Content	pcs/PU	Item no.	€ / PU
6 piece set HSS-E INOX countersinks	403	1x ø6,3 - 8,3 - 10,4 - 12,4 - 16,5 - 20,5mm	1	900.3005	186,49
7 piece set HSS-E INOX countersinks	403	1x ø6,3 - 8,3 - 10,4 - 12,4 - 16,5 - 20,5 - 25,0mm	1	900.3006	249,70

404

HSS Countersink 90°, coated (TiN)

ROTEC®

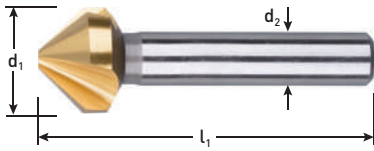

Execution: 90° HSS-G countersinks according to DIN 335-C, cylindrical shank, robust design with 3 flutes. Due to CBN precision ground geometry very sharp and precise cutting edges. TiN-coated for better cutting conditions and increased tool life.

Application: Ideal for deburring or countersinking of the most commonly used materials. Best results with low rpms.
Material groups : 1.1 - 1.4 / 2.1 - 2.2 / 3.1 / 4.1 - 4.12 / 5.1 / 5.3

d ₁	l ₁	d ₂	Suitable for	pcs/PU	Item no.	€ / PU
6,3	45	5	M3	1	404.0630	28,84
8,3	50	6	M4	1	404.0830	31,23
10,4	50	6	M5	1	404.1040	33,56
12,4	56	8	M6	1	404.1240	35,90
16,5	60	8	M8	1	404.1650	80,86
20,5	63	10	M10	1	404.2050	57,67
25,0	67	10	M12	1	404.2500	73,29
31,0	71	12	M16	1	404.3100	101,32

900

HSS Countersink set 90°, coated (TiN), in ABS cassette

ROTEC®



Execution: 90° HSS-G countersinks according to DIN 335-C, cylindrical shank, robust design with 3 flutes. Due to CBN precision ground geometry very sharp and precise cutting edges. TiN-coated for better cutting conditions and increased tool life.

Application: Ideal for deburring or countersinking of the most commonly used materials. Best results with low rpms.
Material groups : 1.1 - 1.4 / 2.1 - 2.2 / 3.1 / 4.1 - 4.12 / 5.1 / 5.3

Description	Type	Content	pcs/PU	Item no.	€ / PU
6 piece set HSS-G countersinks, TiN-coated	404	1x ø6,3 - 8,3 - 10,4 - 12,4 - 16,5 - 20,5mm	1	900.3013	227,66
7 piece set HSS-G countersinks, TiN-coated	404	1x ø6,3 - 8,3 - 10,4 - 12,4 - 16,5 - 20,5 - 25,0mm	1	900.3014	284,92

405

PM Countersink 90°

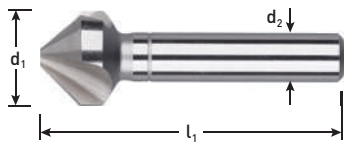

Execution: 90° PM (powder metallurgical steel) countersinks according to DIN 335-C, cylindrical shank, robust design with 3 flutes. Due to CBN precision ground geometry very sharp and precise cutting edges.

Application: Ideal for deburring or countersinking of high tensile steels (>1.000N/mm²) or high abrasive materials like GG cast iron with a hardness of 240HB or more. Best results with low rpms!
Material groups : 1.1 - 1.6 / 2.1 - 2.3 / 3.1 - 3.3 / 5.1 - 5.4

d ₁	l ₁	d ₂	Suitable for	pcs/PU	Item no.	€ / PU
6,3	45	5	M3	1	405.0063	59,06
8,3	50	6	M4	1	405.0083	57,96
10,4	50	6	M5	1	405.0104	67,70
12,4	56	8	M6	1	405.0124	81,83
16,5	60	10	M8	1	405.0165	81,54
20,5	63	10	M10	1	405.0205	109,28
25,0	67	10	M12	1	405.0250	159,18
31,0	71	12	M16	1	405.0310	210,26

Solid carbide countersink 90°



Execution: 90° solid carbide (grade ISO K20) countersinks according to DIN 335-C, cylindrical shank, robust design with 3 flutes. Due to CBN precision ground geometry very sharp and precise cutting edges.

Application: Ideal for deburring or countersinking of high tensile steels (>1.000N/mm²) or high abrasive materials like GG cast iron with a hardness of 240HB or more. Best results with low rpms!
Material groups : 1.1 - 1.6 / 2.1 - 2.3 / 3.1 - 3.3 / 5.1 - 5.4

d ₁	l ₁	d ₂	Suitable for	pcs/PU	Item no.	€ / PU
6,3	45	5	M3	1	405.0630	249,64
8,3	50	6	M4	1	405.0830	280,98
10,4	50	6	M5	1	405.1040	293,68
12,4	56	8	M6	1	405.1240	363,33
16,5	60	10	M8	1	405.1650	432,94
20,5	63	10	M10	1	405.2050	482,96
25,0	67	10	M12	1	405.2500	661,26
31,0	71	12	M16	1	405.3100	831,85

406

HSS Countersink 60°

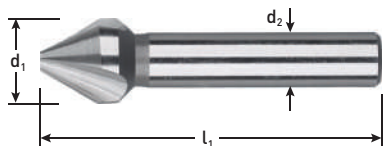

Execution: 60° HSS-G countersinks according to DIN 334-C, cylindrical shank, robust design with 3 flutes. Due to CBN precision ground geometry very sharp and precise cutting edges.

Application: Ideal for deburring or countersinking of the most commonly used materials. Best results with low rpms.
Material groups : 1.1 - 1.4 / 2.1 - 2.2 / 3.1 / 4.1 - 4.12 / 5.1 / 5.3

d ₁	l ₁	d ₂	pcs/PU	Item no.	€ / PU
6,3	45	5	1	406.0630	22,55
8,0	45	5	1	406.0800	23,39
10,0	53	6	1	406.1000	28,84
12,5	56	8	1	406.1250	30,39
16,0	63	10	1	406.1600	38,18
20,0	67	10	1	406.2000	53,07
25,0	71	10	1	406.2500	72,37

More precise, more powerful and stronger!

- achieves the best performance in almost all materials and applications
- considerably less feed force required
- up to 60% longer service life
- up to 30% faster countersinking
- extremely quiet running
- optimal and smooth surface
- perfect chip removal

Revolutionary new flute geometries

such as the angle and the radius ensure optimal chip and heat removal and therefore enable high wear resistance. Also, material welding is prevented and countersinking forces are reduced. The variably ground running relief was specially developed and ensures a very quiet countersinking procedure and a perfect surface quality, which guarantees the best results.

3-flat shank

prevents slipping in drill chuck and makes this tool perfectly suitable for use in manual (cordless) power drills.

Standard

Xtreme

Special coating for an even more extended tool life

Xtreme coated

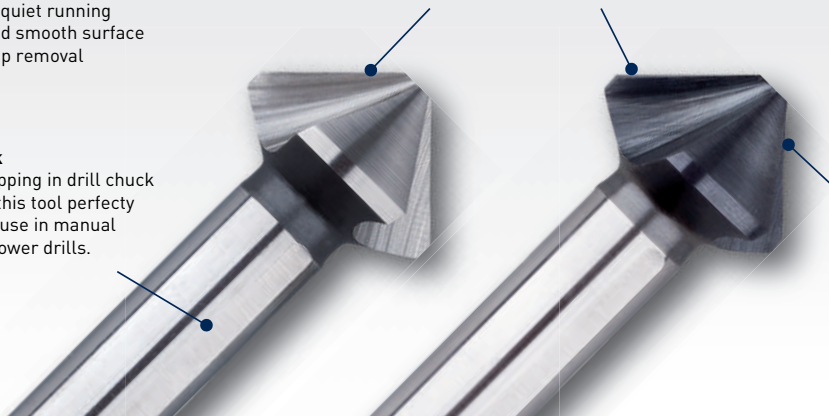

407

HSS-G Countersink 90°, Xtreme



Execution: 90° HSS-G countersinks according to DIN 335-C, cylindrical shank, robust design with 3 flutes. Due to CBN precision ground geometry very sharp and precise cutting edges.

Application: Ideal for deburring or countersinking of the most commonly used materials. Best results with low rpms.
Material groups : 1.1 - 1.4 / 2.1 - 2.2 / 3.1 / 4.1 - 4.12 / 5.1 / 5.3



d ₁	l ₁	d ₂	Suitable for	pcs/PU	Item no.	€ / PU
6,3	45	5	M3	1	407.0063	23,05
8,3	50	6	M4	1	407.0083	24,96
10,4	50	6	M5	1	407.0104	26,99
12,4	56	8	M6	1	407.0124	28,89
15,0	60	10		1	407.0150	30,76

d ₁	l ₁	d ₂	Suitable for	pcs/PU	Item no.	€ / PU
16,5	60	10	M8	1	407.0165	33,67
20,5	63	10	M10	1	407.0205	43,40
25,0	67	10	M12	1	407.0250	52,97
31,0	71	12	M16	1	407.0310	75,00

900

HSS-G Countersink set 90°, Xtreme, in ABS cassette



Execution: 90° HSS-G countersinks according to DIN 335-C, cylindrical shank, robust design with 3 flutes. Due to CBN precision ground geometry very sharp and precise cutting edges.

Application: Ideal for deburring or countersinking of the most commonly used materials. Best results with low rpms.
Material groups : 1.1 - 1.4 / 2.1 - 2.2 / 3.1 / 4.1 - 4.12 / 5.1 / 5.3

Description	Type	Content	pcs/PU	Item no.	€ / PU
6 piece set HSS-G countersinks	407	1x ø6,3 - 8,3 - 10,4 - 12,4 - 16,5 - 20,5mm	1	900.3001	193,02

HSS-G Countersink 90°, Xtreme, NanoTec-coated

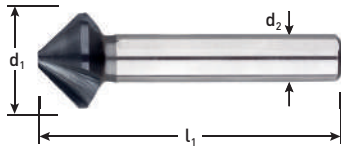

Execution: 90° HSS-G countersinks according to DIN 335-C, cylindrical shank, robust design with 3 flutes. Due to CBN precision ground geometry very sharp and precise cutting edges.

Application: Ideal for deburring or countersinking of the most commonly used materials. Best results with low rpms.
Material groups : 1.1 - 1.4 / 2.1 - 2.2 / 3.1 / 4.1 - 4.12 / 5.1 / 5.3



d ₁	l ₁	d ₂	Suitable for	pcs/PU	Item no.	€ / PU
6,3	45	5	M3	1	407.1063	33,55
8,3	50	6	M4	1	407.1083	37,26
10,4	50	6	M5	1	407.1104	38,00
12,4	56	8	M6	1	407.1124	45,25
15,0	60	10		1	407.1150	46,22

d ₁	l ₁	d ₂	Suitable for	pcs/PU	Item no.	€ / PU
16,5	60	10	M8	1	407.1165	52,54
20,5	63	10	M10	1	407.1205	65,22
25,0	67	10	M12	1	407.1250	78,89
31,0	71	12	M16	1	407.1310	96,11

HSS-G Countersink set 90°, Xtreme, NanoTec-coated, in ABS cassette



Execution: 90° HSS-G countersinks according to DIN 335-C, cylindrical shank, robust design with 3 flutes. Due to CBN precision ground geometry very sharp and precise cutting edges.

Application: Ideal for deburring or countersinking of the most commonly used materials. Best results with low rpms.
Material groups : 1.1 - 1.4 / 2.1 - 2.2 / 3.1 / 4.1 - 4.12 / 5.1 / 5.3

Description	Type	Content	pcs/PU	Item no.	€ / PU
6 piece set HSS-G countersinks, coated	407	1x ø6,3 - 8,3 - 10,4 - 12,4 - 16,5 - 20,5mm	1	900.3002	282,04

409 HSS Countersink 120°

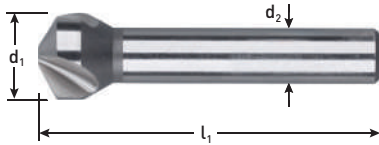

Execution: 120° HSS-G countersinks, shape C, cylindrical shank, robust design with 3 flutes. Due to CBN precision ground geometry very sharp and precise cutting edges.

Application: Ideal for deburring or countersinking of the most commonly used materials. Best results with low rpms.
Material groups : 1.1 - 1.4 / 2.1 - 2.2 / 3.1 / 4.1 - 4.12 / 5.1 / 5.3

d ₁	l ₁	d ₂	pcs/PU	Item no.	€ / PU
6,3	45	5	1	409.0630	29,62
8,3	50	6	1	409.0830	30,39
10,4	50	6	1	409.1040	34,35
12,4	56	8	1	409.1240	37,39
16,5	63	10	1	409.1650	49,12
20,5	67	10	1	409.2050	69,47
25,0	71	10	1	409.2500	91,94

413 HSS Countersink 90°, 1 flute

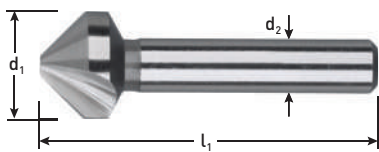

Execution: 90° HSS-G countersinks, shape C, cylindrical shank, robust design with 1 flute. Due to CBN precision ground geometry very sharp and precise cutting edges.

Application: Ideal for deburring or countersinking of the most commonly used materials. Best results with low rpms.
Material groups : 1.1 - 1.4 / 2.1 - 2.2 / 3.1 / 4.1 - 4.12 / 5.1 / 5.3

d ₁	l ₁	d ₂	pcs/PU	Item no.	€ / PU
6,0	45	5	1	413.0600	23,39
8,0	50	6	1	413.0800	24,89
10,0	50	6	1	413.1000	26,50
12,0	56	8	1	413.1200	32,74
16,0	60	10	1	413.1600	36,53
20,0	63	10	1	413.2000	47,57
25,0	67	10	1	413.2500	60,06
30,0	71	12	1	413.3000	63,90

538 HSS-E Countersink 90°, weldon 19mm

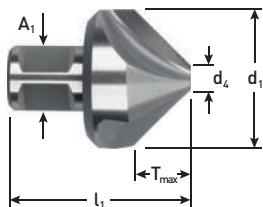

Execution: HSS-E countersinks, 90°, CBN ground cutting edges and flutes for extremely stable countersinking/chamfering applications. With WELDON 19mm shank.

Application: For magnetic core drills or drill presses with either WELDON-type spindle mount or morse taper spindle mount in conjunction with an appropriate adapter.
For drilling in most commonly used materials such as construction steels, mild steels and alloyed steels.

d ₁	l ₁	d ₄	T _{max}	A ₁	pcs/PU	Item no.	€ / PU
25	43	4	10	WLD 19	1	538.9325	35,87
30	47	4	13	WLD 19	1	538.9330	45,14
40	52	7	16	WLD 19	1	538.9340	64,55
55	63	9	23	WLD 19	1	538.9355	120,28

415 Universal handle



Execution: Ergonomically designed handles for manual deburring operations. For countersinks with ø8 or ø10mm cylindrical shanks.

Application: Manually deburring of holes.

d ₁	l ₁	pcs/PU	Item no.	€ / PU
8	113	1	415.0800	27,29
10	113	1	415.1000	33,56

HSS-G Countersink with handle



Execution: 90° HSS-G Hand deburrers with countersinks according to DIN 335-C, robust design with 3 flutes with a fixed ergonomically designed handle.
The countersink tool bit is NOT replaceable!

Application: Manually deburring of holes.
Material groups : 1.1 - 1.4 / 2.1 - 2.2 / 3.1 / 4.1 - 4.12 / 5.1 / 5.3

d ₁	l ₁	pcs/PU	Item no.	€ / PU
12,4	130	1	415.1240	42,06
15,0	150	1	415.1500	43,68
16,5	150	1	415.1650	46,01
20,5	150	1	415.2050	53,78
25,0	150	1	415.2500	61,62

417

HSS-E Cross hole countersink 90°

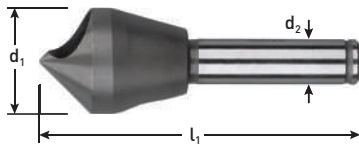

Execution: 90° HSS-E cross hole countersinks, cylindrical shank. Chip evacuation through cross hole avoids chips getting stuck between cutter and workpiece.

Application: Ideal for deburring or countersinking of the most commonly used materials. Best results with low rpms.
Material groups : 1.1 - 1.4 / 2.1 - 2.2 / 3.1 / 4.1 - 4.12 / 5.1 / 5.3

d (min-max)	d ₁	l ₁	d ₂	pcs/PU	Item no.	€ / PU
1 - 4	6,35	45	6,35	1	417.0001	34,61
2 - 5	10	45	6	1	417.0005	22,55
5 - 10	14	48	8	1	417.0010	27,29
10 - 15	21	65	10	1	417.0015	46,01
15 - 20	28	85	12	1	417.0020	77,13
20 - 25	35	102	15	1	417.0025	127,07
25 - 30	44	115	15	1	417.0030	219,80
35 - 40	53	136	15	1	417.0040	565,08
40 - 50	64	166	18	1	417.0050	565,08

900

HSS-E Cross hole countersink set 90°, in ABS-cassette



Execution: 90° HSS-E cross hole countersinks, cylindrical shank. Chip evacuation through cross hole avoids chips getting stuck between cutter and workpiece.

Application: Ideal for deburring or countersinking of the most commonly used materials. Best results with low rpms.
Material groups : 1.1 - 1.4 / 2.1 - 2.2 / 3.1 / 4.1 - 4.12 / 5.1 / 5.3

Description	Type	Content	pcs/PU	Item no.	€ / PU
4 piece set cross hole countersinks	417	1x ø10 - 14 - 21 - 28mm	1	900.3007	143,11

418

HSS-G Counterbore, fine tolerance



Execution: HSS-G counterbores, 180°, according to DIN 373, cylindrical shank and fixed pilot tip. For through holes.

Application: For countersinking all types of cylinder head screws and nuts. Best results with low rpms. Material groups : 1.1 - 1.4 / 2.1 - 2.2 / 3.1 / 4.1 - 4.12 / 5.1 / 5.3

Suitable for	d ₁	d ₄	l ₁	d ₂	pcs/PU	Item no.	€ / PU
M3	6	3,2	71	5	1	418.0002	31,17
M4	8	4,3	71	5	1	418.0004	31,99
M5	10	5,3	80	8	1	418.0006	32,87
M6	11	6,4	80	8	1	418.0008	36,98
M8	15	8,4	100	12,5	1	418.0010	45,98
M10	18	10,5	100	12,5	1	418.0012	50,89
M12	20	13,0	100	12,5	1	418.0014	55,87

HSS-G Counterbore, medial tolerance



Execution: HSS-G counterbores, 180°, according to DIN 373, cylindrical shank and fixed pilot tip. For through holes.

Application: For countersinking all types of cylinder head screws and nuts. Best results with low rpms. Material groups : 1.1 - 1.4 / 2.1 - 2.2 / 3.1 / 4.1 - 4.12 / 5.1 / 5.3

Suitable for	d ₁	d ₄	l ₁	d ₂	pcs/PU	Item no.	€ / PU
M3	6	3,4	71	5	1	418.0020	31,17
M4	8	4,5	71	5	1	418.0022	31,99
M5	10	5,5	80	8	1	418.0024	32,87
M6	11	6,6	80	8	1	418.0026	36,98
M8	15	9,0	100	12,5	1	418.0028	45,98
M10	18	11,0	100	12,5	1	418.0030	50,89
M12	20	13,5	100	12,5	1	418.0032	55,87

HSS-G Counterbore, core holes



Execution: HSS counterbores, 180°, according to DIN 373, cylindrical shank and fixed pilot tip. For core holes (same as the pre-tap diameter for metric threads).

Application: For countersinking all types of cylinder head screws and nuts. Best results with low rpms. Material groups : 1.1 - 1.4 / 2.1 - 2.2 / 3.1 / 4.1 - 4.12 / 5.1 / 5.3

Suitable for	d ₁	d ₄	l ₁	d ₂	pcs/PU	Item no.	€ / PU
M3	6	2,5	71	5	1	418.0040	31,17
M4	8	3,3	71	5	1	418.0042	31,99
M5	10	4,2	80	8	1	418.0044	32,87
M6	11	5,0	80	8	1	418.0046	36,98
M8	15	6,8	100	12,5	1	418.0048	45,98
M10	18	8,5	100	12,5	1	418.0050	50,89
M12	20	10,2	100	12,5	1	418.0052	55,87

900

HSS-G Counterbore set, in ABS cassette



Execution: HSS-G counterbores, 180°, according to DIN 373, cylindrical shank and fixed pilot tip. For through holes.

Application: For countersinking all types of cylinder head screws and nuts. Best results with low rpms. Material groups : 1.1 - 1.4 / 2.1 - 2.2 / 3.1 / 4.1 - 4.12 / 5.1 / 5.3

Description	Type	Content	pcs/PU	Item no.	€ / PU
6 piece counterbore set, fine	418	1x M3, M4, M5, M6, M8 and M10	1	900.3050	221,53
6 piece counterbore set, medial	418	1x M3, M4, M5, M6, M8 and M10	1	900.3052	221,53
6 piece counterbore set, core holes	418	1x M3, M4, M5, M6, M8 and M10	1	900.3054	217,69

420

HSS Tube & sheet drill bit

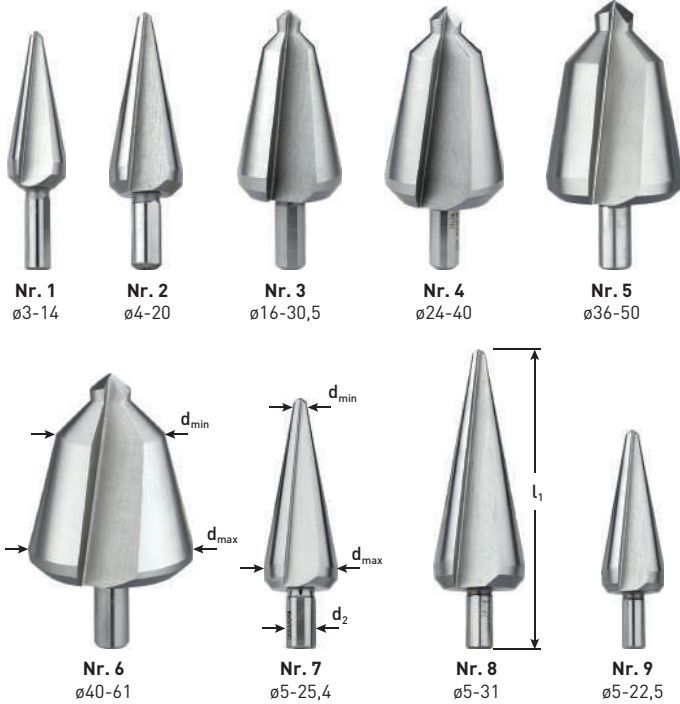

Execution: HSS tube & sheet drill bits with cylindrical shank. Split-point according to DIN1412-C. Cone shaped back-end of the tool facilitates easy withdrawal of the tool after having punctured sheet metal with the tool's widest diameter.

Application: Ideal tool for automotive, electrical, aviation, machine building industry, switchboards and plumbers. Stepless centring, drilling and boring without deformation of the workpiece.
Material groups : 1.1 - 1.3 / 4.1 / 4.4 - 4.6 / 4.9 - 4.11 - 4.12

Nr.	d (min-max)	l ₁	d ₂	pcs/PU	Item no.	€ / PU
1	3 - 14	58	6	1	420.0001	23,26
2	5 - 20	71	8	1	420.0002	34,14
3	16 - 30,5	76	8	1	420.0003	61,94
4	24 - 40	89	10	1	420.0004	124,70
5	36 - 50	97	12	1	420.0005	185,84
6	40 - 61	103	13	1	420.0006	263,88
7	5 - 25,4	87	10	1	420.0007	65,05
8	5 - 31	103	9	1	420.0008	80,17
9	5 - 22,5	79	8	1	420.0009	48,21

900

HSS Tube & sheet drill bit set, in ABS cassette



Execution: HSS tube & sheet drill bits with cylindrical shank. Split-point according to DIN1412-C. Cone shaped back-end of the tool facilitates easy withdrawal of the tool after having punctured sheet metal with the tool's widest diameter.

Application: Ideal tool for automotive, electrical, aviation, machine building industry, switchboards and plumbers. Stepless centring, drilling and boring without deformation of the workpiece.
Material groups : 1.1 - 1.3 / 4.1 / 4.4 - 4.6 / 4.9 - 4.11 - 4.12

Description	Type	Content	pcs/PU	Item no.	€ / PU
3 piece tube & sheet drill bit set	420	Nr. 1, 2 and 3 / 1 piece each.	1	900.3020	127,66

420

HSS-E Tube & sheet drill bit

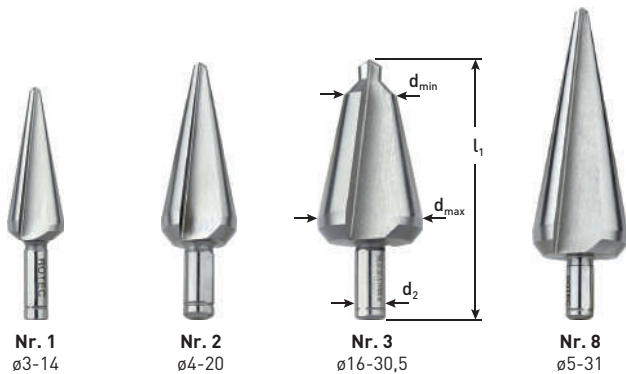

Execution: HSS-E tube & sheet drill bits with cylindrical shank. Split-point according to DIN1412-C. Cone shaped back-end of the tool facilitates easy withdrawal of the tool after having punctured sheet metal with the tool's widest diameter.

Application: Ideal tool for automotive, electrical, aviation, machine building industry, switchboards and plumbers. Stepless centring, drilling and boring without deformation of the workpiece.
Material groups : 1.1 - 1.3 / 2.1 - 2.2 / 4.1 / 4.4 - 4.6 / 4.9 - 4.11 - 4.12

Nr.	d (min-max)	l ₁	d ₂	pcs/PU	Item no.	€ / PU
1	3 - 14	58	6	1	420.0101	32,94
2	5 - 20	71	8	1	420.0102	48,21
3	16 - 30,5	76	9	1	420.0103	87,11
8	5 - 31	103	9	1	420.0108	111,64

HSS Tube & sheet drill bit, coated (TiN)

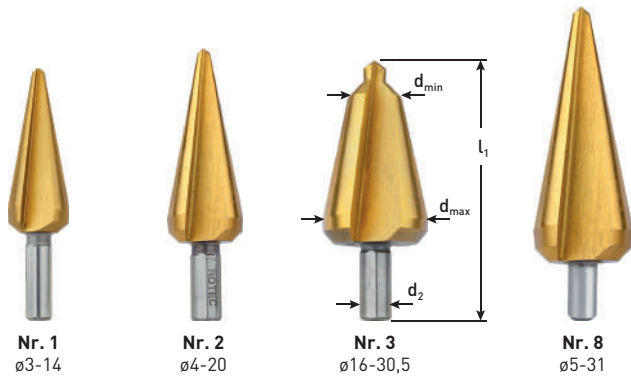

Execution: HSS tube & sheet drill bits with cylindrical shank. Split-point according to DIN1412-C. Cone shaped back-end of the tool facilitates easy withdrawal of the tool after having punctured sheet metal with the tool's widest diameter. TiN-coated for increased tool life.

Application: Ideal tool for automotive, electrical, aviation, machine building industry, switchboards and plumbers. Stepless centring, drilling and boring without deformation of the workpiece.
Material groups : 1.1 - 1.3 / 4.1 / 4.4 - 4.6 / 4.9 - 4.11 - 4.12

Nr.	d (min-max)	l ₁	d ₂	pcs/PU	Item no.	€ / PU
1	3 - 14	58	6	1	420.1001	43,56
2	5 - 20	71	8	1	420.1002	62,71
3	16 - 30,5	76	9	1	420.1003	130,87
8	5 - 31	103	9	1	420.1008	146,89

900

HSS Tube & sheet drill bit set, coated (TiN), in ABS cassette



Execution: HSS tube & sheet drill bits with cylindrical shank. Split-point according to DIN1412-C. Cone shaped back-end of the tool facilitates easy withdrawal of the tool after having punctured sheet metal with the tool's widest diameter. TiN-coated for increased tool life.

Application: Ideal tool for automotive, electrical, aviation, machine building industry, switchboards and plumbers. Stepless centring, drilling and boring without deformation of the workpiece.
Material groups : 1.1 - 1.3 / 4.1 / 4.4 - 4.6 / 4.9 - 4.11 - 4.12

Description	Type	Content	pcs/PU	Item no.	€ / PU
3 piece TiN-coated tube & sheet drill bit set	420.1xxx	Nr. 1, 2 and 3 (TiN-coated) / 1 piece each.	1	900.3025	363,54

422

HSS Tube & sheet drill bit, with stopper

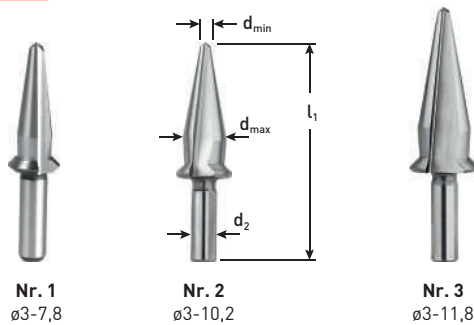

Execution: HSS tube & sheet drill bits with stopper and spot facer for cavity sealing. With split-point according to DIN1412-C and 3-flat cylindrical shank.

Application: Ideal tool for automotive, electrical, aviation, machine building industry, switchboards and plumbers. Stepless centring, drilling and boring without deformation of the workpiece.
Material groups : 1.1 - 1.3 / 4.1 / 4.4 - 4.6 / 4.9 - 4.11 - 4.12

Nr.	d (min-max)	l ₁	d ₂	pcs/PU	Item no.	€ / PU
1	3 - 7,8	48	6	1	422.0001	43,56
2	3 - 10,2	52	6	1	422.0002	40,57
3	3 - 11,8	56	6	1	422.0003	42,86

423

HSS Tube & sheet drill bit, 1/4" bit shank

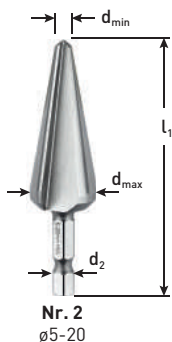

Execution: HSS tube & sheet drill bits with 1/4" hexagon shank. Split-point according to DIN1412-C. Cone shaped back-end of the tool facilitates easy withdrawal of the tool after having punctured sheet metal with the tool's widest diameter.

Application: Ideal tool for automotive, electrical, aviation, machine building industry, switchboards and plumbers. Stepless centering, drilling and boring without deformation of the workpiece.
Material groups : 1.1 - 1.3 / 4.1 / 4.4 - 4.6 / 4.9 - 4.11 - 4.12

Nr.	d (min-max)	l ₁	d ₂	pcs/PU	Item no.	€ / PU
2	5 - 20	78	1/4"	1	423.0002	49,73

425

HSS Step drill bit

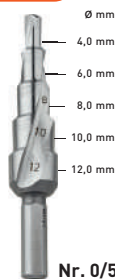

Nr. 0/5



Nr. 0/9



Nr. 1



Nr. 2



Nr. 3

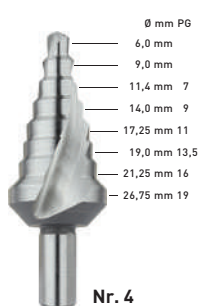

Nr. 4



Nr. 5



Nr. 6

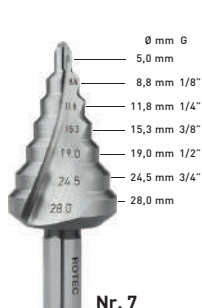

Nr. 7

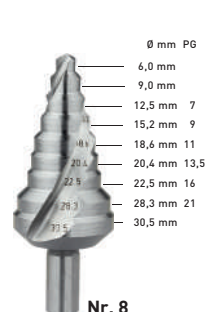

Nr. 8

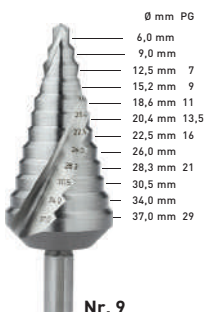

Nr. 9

Execution: HSS step drill bits with spiral flutes, split-point according to DIN1412-C and a 3-flat cylindrical shank. Optimized chip-flow, also of non-breaking chips, protects cuttings edges and guarantees a smooth and high-performance cutting process.

Application: Suitable for most common materials. Steel sheet material up to 4mm thickness. Increase tool life considerably with Rotec cutting oil RS50 or Rotec cutting paste.
Material groups : 1.1 - 1.3 / 4.1 - 4.12

Nr.	d (min-max)	Z _T	l ₁	d ₂	pcs/PU	Item no.	€ / PU
0/5	4 - 12	5	65	6	1	425.0005	38,35
0/9	4 - 12	9	65	6	1	425.0009	34,52
1	4 - 20	9	75	8	1	425.0010	50,68
2	4 - 30	14	100	10	1	425.0020	97,89
3	6 - 38	12	100	10	1	425.0030	137,39
4	6 - 26,75	8	75	10	1	425.0040	75,91
5	4 - 39	13	107	10	1	425.0050	155,79
6	6 - 32	8	75	10	1	425.0060	134,63
7	5 - 28	7	69	10	1	425.0070	67,39
8	6 - 30,5	9	80	10	1	425.0080	86,19
9	6 - 37	12	100	10	1	425.0090	124,79
13	6 - 40	12	100	10	1	425.0100	323,48

900

HSS Step drill bit set, in ABS cassette



Execution: HSS step drill bits with spiral flutes, split-point according to DIN1412-C and a 3-flat cylindrical shank. Optimized chip-flow, also of non-breaking chips, protects cuttings edges and guarantees a smooth and high-performance cutting process.

Application: Suitable for most common materials. Steel sheet material up to 4mm thickness. Increase tool life considerably with Rotec cutting oil RS50 or Rotec cutting paste.
Material groups : 1.1 - 1.3 / 4.1 - 4.12

Description	Type	Content	pcs/PU	Item no.	€ / PU
3 piece step drill bit set	425	Nr. 0/9, 1 and 2 / 1 pc each.	1	900.3030	200,28

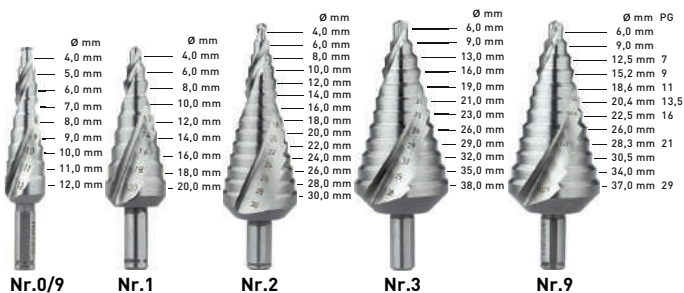

Execution: HSS-E step drill bits with spiral flutes, split-point according to DIN1412-C and a 3-flat cylindrical shank. Optimized chip-flow, also of non-breaking chips, protects cuttings edges and guarantees a smooth and high-performance cutting process.

Application: Suitable for most common materials. Steel sheet material up to 4mm thickness. Increase tool life considerably with Rotec cutting oil RS50 or Rotec cutting paste. Material groups : 1.1 - 1.3 / 2.1 - 2.2 / 4.1 - 4.12

Nr.	d (min-max)	Z _T	l ₁	d ₂	pcs/PU	Item no.	€ / PU
0/9	4 - 12	9	65	6	1	425.0109	50,91
1	4 - 20	9	75	8	1	425.0110	75,12
2	4 - 30	14	100	10	1	425.0120	144,78
3	6 - 38	12	100	10	1	425.0130	186,91
9	6 - 37	12	100	10	1	425.0190	184,75

HSS Step drill bit, coated (TiN)

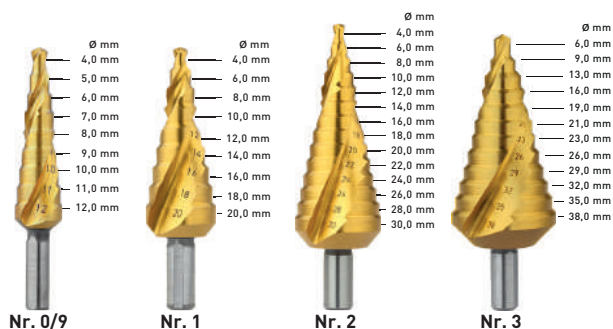

Execution: HSS step drill bits with spiral flutes, split-point according to DIN1412-C and a 3-flat cylindrical shank. Optimized chip-flow, also of non-breaking chips, protects cuttings edges and guarantees a smooth and high-performance cutting process. TiN-coating for increased tool-life.

Application: Suitable for most common materials. Steel sheet material up to 4mm thickness. Increase tool life considerably with Rotec cutting oil RS50 or Rotec cutting paste. Material groups : 1.1 - 1.3 / 4.1 - 4.12

Nr.	d (min-max)	Z _T	l ₁	d ₂	pcs/PU	Item no.	€ / PU
0/9	4 - 12	9	65	6	1	425.0209	48,33
1	4 - 20	9	75	8	1	425.0210	70,95
2	4 - 30	14	100	10	1	425.0220	137,05
3	6 - 38	12	100	10	1	425.0230	192,35

HSS Step drill bit, coated (TiAlN)

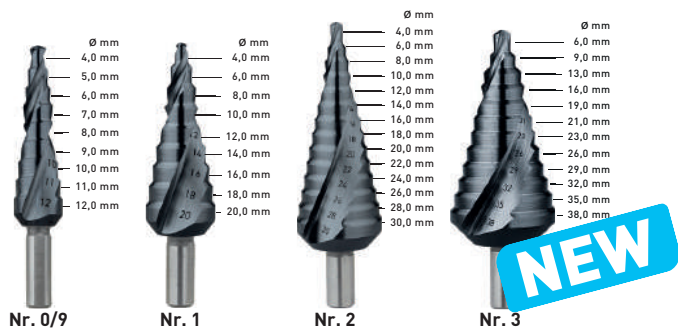

Execution: HSS step drill bits with spiral flutes, split-point according to DIN1412-C and a 3-flat cylindrical shank. Optimized chip-flow, also of non-breaking chips, protects cuttings edges and guarantees a smooth and high-performance cutting process. TiAlN-coating for increased tool-life.

Application: Suitable for most common materials. Steel sheet material up to 4mm thickness. Increase tool life considerably with Rotec cutting oil RS50 or Rotec cutting paste. Material groups : 1.1 - 1.3 / 4.1 - 4.12

Nr.	d (min-max)	Z _T	l ₁	d ₂	pcs/PU	Item no.	€ / PU
0/9	4 - 12	9	65	6	1	425.0309	51,78
1	4 - 20	9	75	8	1	425.0310	76,02
2	4 - 30	14	100	10	1	425.0320	146,84
3	6 - 38	12	100	10	1	425.0330	206,09

HSS Step drill bit IMPACT, coated (TiAlN)



Execution: HSS-TiAlN coated IMPACT with 1/4" HEX shank, Optimized chip-flow, also of non-breaking chips, protects cuttings edges and guarantees a smooth and high-performance cutting process. TiAlN-coating for increased tool-life.

Application: Suitable for most common materials. Steel sheet material up to 4mm thickness. Increase tool life considerably with Rotec cutting oil RS50 or Rotec cutting paste. Material groups : 1.1 - 1.3 / 4.1 - 4.12

Nr.	d (min-max)	Z _T	l ₁	d ₂	pcs/PU	Item no.	€ / PU
1	4 - 20	9	75	1/4"	1	425.0410	79,82
2	4 - 30	14	100	1/4"	1	425.0420	154,18

HSS Step drill bit (<2mm)



Execution: HSS step drill bits with spiral flutes, split-point according to DIN1412-C and a 3-flat cylindrical shank. Thanks to 2.0mm step height ideal for the switchboard producing industry and for use on thin sheets in general.

Application: Suitable for most common materials. Steel sheet material up to 2mm thickness. Increase tool life considerably with Rotec cutting oil RS50 or Rotec cutting paste.
Material groups : 1.1 - 1.3 / 2.1 - 2.2 / 4.1 - 4.12

Nr.	d (min-max)	Z _T	l ₁	d ₂	pcs/PU	Item no.	€ / PU
0/9	4 - 12	9	48	6	1	426.0001	43,03
1	4 - 20	9	58	8	1	426.0002	54,04
2	4 - 30	14	72	10	1	426.0003	75,12

HSS Step drill bit, for metric cable connectors, through holes

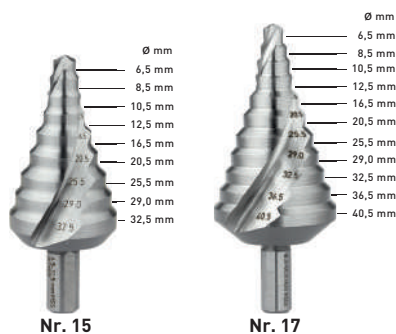

Execution: HSS step drill bits with spiral flutes, split-point according to DIN1412-C and a 3-flat cylindrical shank. Specifically designed for metric cable connectors, through holes, according to DIN/EN 50262.

Application: Suitable for most common materials. Steel sheet material up to 2mm thickness. Increase tool life considerably with Rotec cutting oil RS50 or Rotec cutting paste.
Material groups : 1.1 - 1.3 / 2.1 - 2.2 / 4.1 - 4.12

Nr.	d (min-max)	Z _T	l ₁	d ₂	pcs/PU	Item no.	€ / PU
15	6,5 - 32,5	9	79	10	1	426.0011	121,35
17	6,5 - 40,5	11	96	10	1	426.0012	144,78

HSS Step drill bit, for metric cable connectors, core holes

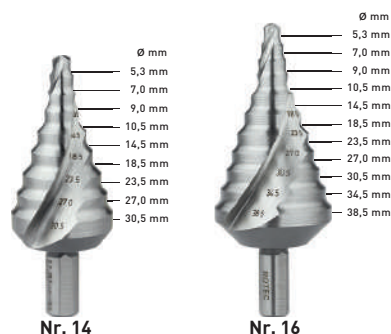

Execution: HSS step drill bits with spiral flutes, split-point according to DIN1412-C and a 3-flat cylindrical shank. Specifically designed for metric cable connectors, core holes, according to DIN/EN 50262.

Application: Suitable for most common materials. Steel sheet material up to 4mm thickness. Increase tool life considerably with Rotec cutting oil RS50 or Rotec cutting paste.
Material groups : 1.1 - 1.3 / 2.1 - 2.2 / 4.1 - 4.12

Nr.	d (min-max)	Z _T	l ₁	d ₂	pcs/PU	Item no.	€ / PU
14	5,3 - 30,5	9	79	10	1	426.0013	118,99
16	5,3 - 38,5	11	96	10	1	426.0014	143,22

HSS Step drill bit, imperial sizes



Execution: HSS step drill bits with straight flutes, cylindrical shank. Specifically designed for guardrail assembly.

Application: Suitable for most common materials. Steel sheet material up to 2mm thickness. Increase tool life considerably with Rotec cutting oil RS50 or Rotec cutting paste.
Material groups : 1.1 - 1.3 / 2.1 - 2.2 / 4.1 - 4.12

Nr.	d (min-max)	Z _T	l ₁	d ₂	pcs/PU	Item no.	€ / PU
3	1/4" - 3/4"	9	70	3/8"	1	426.0520	88,55

427

HSS-E Spot weld drill bit

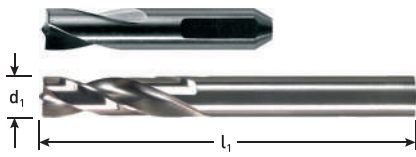

Execution: HSS-E spot weld drill bits, cylindrical shank, very robust design. Specifically designed for drilling spot welds and other difficult drilling applications on sheet materials with (cordless) portable drills.

Application: Burr-free drilling on sheet materials (steel, brass, aluminium, zinc, copper and plastics) without spotting, removal of spot-welds.

d ₁	l ₁	Material	pcs/PU	Item no.	€ / PU
6	66	HSS-E	1	427.0600	10,97
6,5	40	HSS-E	1	427.0651	27,98
8	79	HSS-E	1	427.0800	11,69
8	40	HSS-E	1	427.0801	14,57

HSS-E Spot weld drill bit, coated (TiAlN)



Execution: HSS-E spot weld drill bits, cylindrical shank, very robust design. Specifically designed for drilling spot welds and other difficult drilling applications on sheet materials with (cordless) portable drills.

Application: Burr-free drilling on sheet materials (steel, brass, aluminium, zinc, copper and plastics) without spotting, removal of spot-welds.

d ₁	l ₁	Material	pcs/PU	Item no.	€ / PU
8	79	HSS-E	1	427.0800T	24,54

ROTEC Carbide burrs | A perfect cut for every application!

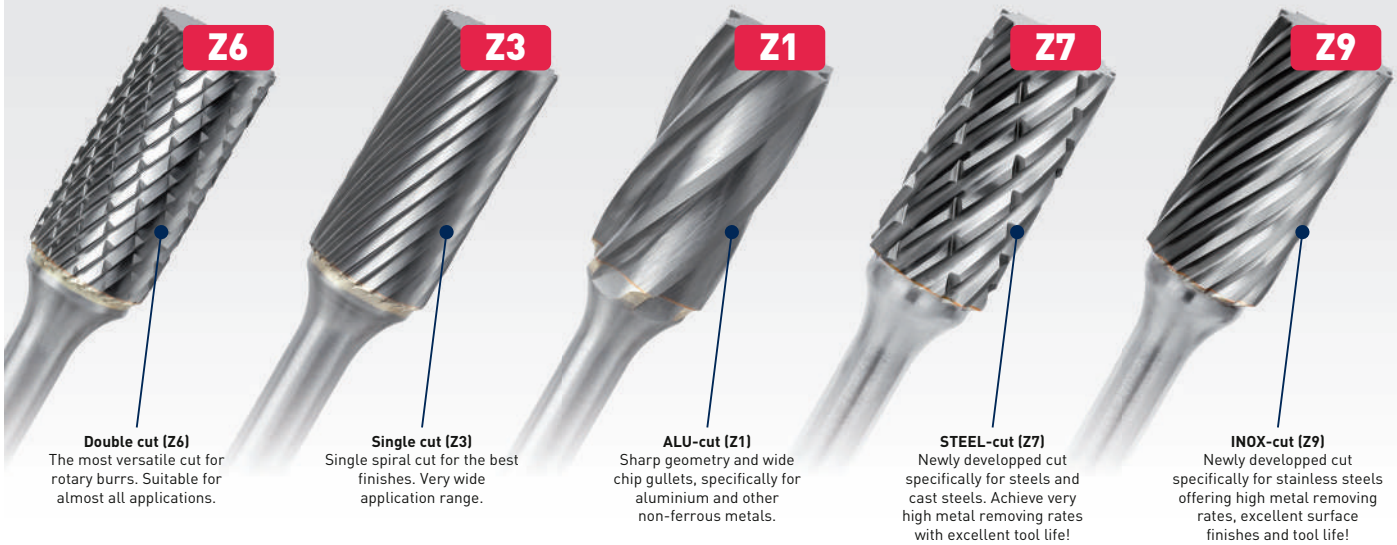

Execution: Carbide rotary burrs, cylinder shape, without end cut, in different cuts. Shape A (ISO: ZYA).

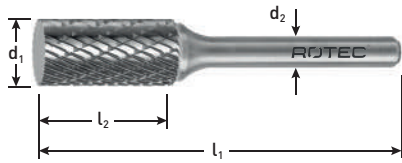

Double cut
(Z6)

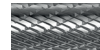

Spiral cut
(Z3)



ALU-cut
(Z1)



STEEL-cut
(Z7)



INOX-cut
(Z9)



d ₁	l ₁	l ₂	d ₂	Z _f	pcs/PU	Item no.	€/PU
2	38	11	3	Z6	1	430.0201	12,51
3	38	14	3	Z6	1	430.0301	12,51
4	50	13	4	Z6	1	430.0401	20,47
6	50	18	6	Z6	1	430.0601	21,39
6	100	18	6	Z6	1	430.0641	57,01
6	150	18	6	Z6	1	430.0651	87,64
8	64	19	6	Z6	1	430.0801	28,01
9,6	64	19	6	Z6	1	430.1001	30,09
9,6	172	19	6	Z6	1	430.1061	58,75
12,7	70	25	6	Z6	1	430.1301	46,98
12,7	178	25	6	Z6	1	430.1361	83,14
16	70	25	6	Z6	1	430.1601	59,24
6	50	18	6	Z3	1	430.0605	21,39
8	64	19	6	Z3	1	430.0805	28,01
9,6	64	19	6	Z3	1	430.1005	30,09
12,7	70	25	6	Z3	1	430.1305	46,98
9,6	64	19	6	Z1	1	430.1002	37,71
12,7	70	25	6	Z1	1	430.1302	58,87
8	64	19	6	Z7	1	430.0807	30,84
9,6	64	19	6	Z7	1	430.1007	33,10
12,7	70	25	6	Z7	1	430.1307	51,68
6	50	18	6	Z9	1	430.0609	25,73
8	64	19	6	Z9	1	430.0809	33,60
9,6	64	19	6	Z9	1	430.1009	36,15
12,7	70	25	6	Z9	1	430.1309	56,36

430

Carbide bur, cylinder with radius, shape AR

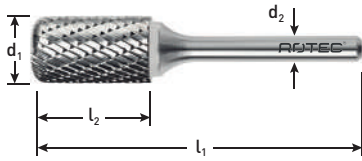

Corner radius for stronger edges and more control of the burr when operating.

Execution: With corner radius giving the operator extra control of the tool. The radius avoids "biting" in the material causing the tool to run-off and damage the workpiece.

d ₁	l ₁	l ₂	d ₂	Z _f	pcs/PU	Item no.	€ / PU
3	38	14	3	Z6	1	430.3030	14,34
6	50	18	6	Z6	1	430.3060	24,65
8	65	19	6	Z6	1	430.3080	32,23
10	65	19	6	Z6	1	430.3100	34,66
12	70	25	6	Z6	1	430.3130	54,03
15	70	25	6	Z6	1	430.3150	68,13



431

Carbide bur, cylinder with end cut, shape B (ZYA-S)

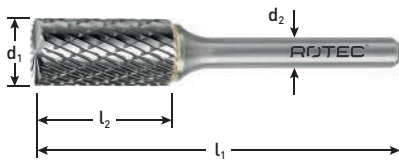

Execution: Carbide rotary burrs, cylinder shape, with end cut, in different cuts. Shape B (ISO: ZYA-S).

d ₁	l ₁	l ₂	d ₂	Z _f	pcs/PU	Item no.	€ / PU
2	38	11	3	Z6	1	431.0201	13,77
3	38	14	3	Z6	1	431.0301	13,77
4	50	13	4	Z6	1	431.0401	25,73
6	50	18	6	Z6	1	431.0601	23,51
6	100	18	6	Z6	1	431.0641	62,68
6	150	18	6	Z6	1	431.0651	96,39
8	64	19	6	Z6	1	431.0801	30,78
9,6	64	19	6	Z6	1	431.1001	33,10
9,6	172	19	6	Z6	1	431.1061	64,61
12,7	70	25	6	Z6	1	431.1301	51,68
12,7	178	25	6	Z6	1	431.1361	91,44
16	70	25	6	Z6	1	431.1601	65,18
6	50	18	6	Z3	1	431.0605	23,51
8	64	19	6	Z3	1	431.0805	30,78
9,6	64	19	6	Z3	1	431.1005	33,10
12,7	70	25	6	Z3	1	431.1305	51,68
9,6	64	19	6	Z1	1	431.1002	41,54
12,7	70	25	6	Z1	1	431.1302	64,73
8	64	19	6	Z7	1	431.0807	33,90
9,6	64	19	6	Z7	1	431.1007	36,40
12,7	70	25	6	Z7	1	431.1307	56,86

432

Carbide bur, ball nosed cylinder, shape C (WRC)



Double cut
[Z6]



Spiral cut
[Z3]



ALU-cut
[Z1]



STEEL-cut
[Z7]



INOX-cut
[Z9]



Execution: Carbide rotary burrs, cylinder shape, with ball nose, in different cuts. Shape C (ISO: WRC).

d ₁	l ₁	l ₂	d ₂	Z _f	pcs/PU	Item no.	€ / PU
2	38	11	3	Z6	1	432.0201	12,51
3	38	14	3	Z6	1	432.0301	12,51
6	50	18	6	Z6	1	432.0601	24,91
6	60	19	6	Z6	1	432.0601-60	38,84
6	80	19	6	Z6	1	432.0601-80	48,24
6	100	19	6	Z6	1	432.0601-100	58,99
6	150	19	6	Z6	1	432.0601-150	89,65
8	64	19	6	Z6	1	432.0801	30,47
9,6	64	19	6	Z6	1	432.1001	33,52
9,6	172	19	6	Z6	1	432.1061	55,16
12,7	70	25	6	Z6	1	432.1301	52,67
12,7	178	25	6	Z6	1	432.1361	78,27
16	70	25	6	Z6	1	432.1601	66,30
6	50	18	6	Z3	1	432.0605	24,91
8	64	19	6	Z3	1	432.0805	30,47
9,6	64	19	6	Z3	1	432.1005	33,52
12,7	70	25	6	Z3	1	432.1305	52,67
9,6	64	19	6	Z1	1	432.1002	42,04
12,7	70	25	6	Z1	1	432.1302	66,06
8	64	19	6	Z7	1	432.0807	33,52
9,6	64	19	6	Z7	1	432.1007	36,90
12,7	70	25	6	Z7	1	432.1307	57,99
6	50	18	6	Z9	1	432.0609	29,89
8	64	19	6	Z9	1	432.0809	36,61
9,6	64	19	6	Z9	1	432.1009	40,21
12,7	70	25	6	Z9	1	432.1309	63,25

432

Carbide bur, for locksmiths

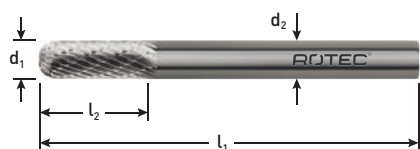

Double cut
[Z6]



Ideal for locksmiths!!



Execution: Carbide rotary burrs, cylinder shape, with ball nose, in different cuts. Shape C (ISO: WRC).

d ₁	l ₁	l ₂	d ₂	Z _f	pcs/PU	Item no.	€ / PU
2	38	11	3	Z6	1	432.0201	12,51
3	38	14	3	Z6	1	432.0301	12,51
6	50	18	6	Z6	1	432.0601	24,91
6	60	19	6	Z6	1	432.0601-60	38,84
6	80	19	6	Z6	1	432.0601-80	48,24
6	100	19	6	Z6	1	432.0601-100	58,99
6	150	19	6	Z6	1	432.0601-150	89,65

433

Carbide bur, ball, shape D (KUD)



Execution: Carbide rotary burrs, ball shape, in different cuts. Shape D (ISO: KUD).

Double cut
(Z6)



ALU-cut
(Z1)



STEEL-cut
(Z7)



INOX-cut
(Z9)



d ₁	l ₁	l ₂	d ₂	Z _f	pcs/PU	Item no.	€/ PU
3	38	2,5	3	Z6	1	433.0301	12,51
4	38	3,4	3	Z6	1	433.0401	30,09
6	50	4,7	6	Z6	1	433.0601	22,88
8	52	6	6	Z6	1	433.0801	24,58
9,6	54	8,0	6	Z6	1	433.1001	27,54
9,6	187	8	6	Z6	1	433.1061	47,48
12,7	56	11	6	Z6	1	433.1301	37,16
12,7	164	11	6	Z6	1	433.1361	58,24
16	59	14	6	Z6	1	433.1601	45,99
9,6	54	8,0	6	Z1	1	433.1002	34,47
12,7	56	11	6	Z1	1	433.1302	46,54
16	59	14	6	Z1	1	433.1602	57,60
8	52	6	6	Z7	1	433.0807	27,09
9,6	54	8	6	Z7	1	433.1007	30,28
12,7	56	11	6	Z7	1	433.1307	40,85
6	50	4,7	6	Z9	1	433.0609	27,47
8	52	6	6	Z9	1	433.0809	29,53
9,6	54	8	6	Z9	1	433.1009	33,02
12,7	56	11	6	Z9	1	433.1309	44,54



434

Carbide bur, oval, shape E (TRE)

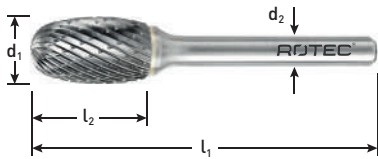

Execution: Carbide rotary burrs, oval shape, in different cuts. Shape E (ISO: TRE).

Double cut
(Z6)



ALU-cut
(Z1)



STEEL-cut
(Z7)



INOX-cut
(Z9)



d ₁	l ₁	l ₂	d ₂	Z _f	pcs/PU	Item no.	€/ PU
3	38	6	3	Z6	1	434.0301	12,51
6,3	42	9,5	3	Z6	1	434.0601	20,52
6	50	10	6	Z6	1	434.0611	28,01
8	60	15	6	Z6	1	434.0801	30,63
9,6	60	16	6	Z6	1	434.1001	33,52
9,6	168	16	6	Z6	1	434.1061	55,49
12,7	67	22	6	Z6	1	434.1301	49,11
12,7	175	22	6	Z6	1	434.1361	68,83
16	70	25	6	Z6	1	434.1601	68,26
9,6	60	16	6	Z1	1	434.1002	42,04
12,7	67	22	6	Z1	1	434.1302	61,50
12,7	67	22	6	Z7	1	434.1307	54,03
8	60	15	6	Z9	1	434.0809	36,70
9,6	60	16	6	Z9	1	434.1009	40,21
12,7	67	22	6	Z9	1	434.1309	58,92



435

Carbide bur, ball nosed tree, shape F (RBF)



Execution: Carbide rotary burrs, ball nosed tree shape, in different cuts. Shape F (ISO: RBF).

Double cut
(Z6)

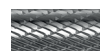

Spiral cut
(Z3)



ALU-cut
(Z1)



STEEL-cut
(Z7)



INOX-cut
(Z9)



d ₁	l ₁	l ₂	d ₂	Z _f	pcs/PU	Item no.	€ / PU
3	38	14	3	Z6	1	435.0301	12,51
6	50	18	6	Z6	1	435.0601	26,01
6	150	18	6	Z6	1	435.0661	89,65
8	65	20	6	Z6	1	435.0801	30,63
9,6	64	19	6	Z6	1	435.1001	32,79
9,6	172	19	6	Z6	1	435.1061	52,86
12,7	70	25	6	Z6	1	435.1301	48,53
12,7	178	25	6	Z6	1	435.1361	69,06
16	70	25	6	Z6	1	435.1601	67,00
6	50	18	6	Z3	1	435.0605	26,01
8	65	20	6	Z3	1	435.0805	30,63
9,6	64	19	6	Z3	1	435.1005	32,79
12,7	70	25	6	Z3	1	435.1305	48,53
9,6	64	19	6	Z1	1	435.1002	41,12
12,7	70	25	6	Z1	1	435.1302	60,79
16	70	25	6	Z1	1	435.1602	83,95
8	65	20	6	Z7	1	435.0807	33,73
9,6	64	19	6	Z7	1	435.1007	36,11
12,7	70	25	6	Z7	1	435.1307	53,36
6	50	18	6	Z9	1	435.0609	31,22
8	65	20	6	Z9	1	435.0809	36,70
9,6	64	19	6	Z9	1	435.1009	39,36
12,7	70	25	6	Z9	1	435.1309	58,24

F
Shape



436

Carbide bur, pointed tree, shape G (RBG)



Execution: Carbide rotary burrs, pointed tree shape, in different cuts. Shape G (ISO: RBG).

Double cut
(Z6)

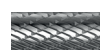

Spiral cut
(Z3)



ALU-cut
(Z1)



STEEL-cut
(Z7)



INOX-cut
(Z9)

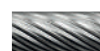

d ₁	l ₁	l ₂	d ₂	Z _f	pcs/PU	Item no.	€ / PU
3	38	14	3	Z6	1	436.0301	12,51
6	50	18	6	Z6	1	436.0601	26,01
8	64	19	6	Z6	1	436.0801	31,60
9,6	64	19	6	Z6	1	436.1001	35,03
9,6	172	19	6	Z6	1	436.1061	55,49
12,7	64	19	6	Z6	1	436.1301	47,63
12,7	178	25	6	Z6	1	436.1361	68,83
12,7	70	25	6	Z6	1	436.1311	47,63
16	70	25	6	Z6	1	436.1601	66,17
3	38	14	3	Z3	1	436.0305	12,51
6	50	18	6	Z3	1	436.0605	26,01
8	64	19	6	Z3	1	436.0805	31,60
9,6	64	19	6	Z3	1	436.1005	35,03
12,7	70	25	6	Z3	1	436.1305	47,63
9,6	64	19	6	Z1	1	436.1002	43,72
12,7	70	25	6	Z1	1	436.1302	59,49
8	64	19	6	Z7	1	436.0807	34,78
9,6	64	19	6	Z7	1	436.1007	38,47
12,7	70	25	6	Z7	1	436.1307	52,36
6	50	18	6	Z9	1	436.0609	31,22
8	64	19	6	Z9	1	436.0809	37,91
9,6	64	19	6	Z9	1	436.1009	41,99
12,7	70	25	6	Z9	1	436.1309	57,12

G
Shape



437

Carbide bur, flame, shape H

Execution: Carbide rotary burrs, flame shape, in different cuts. Shape H.

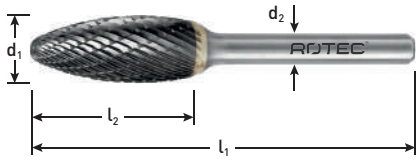

Double cut
(Z6)



ALU-cut
(Z1)



STEEL-cut
(Z7)



INOX-cut
(Z9)



d ₁	l ₁	l ₂	d ₂	Z _f	pcs/PU	Item no.	€ / PU
3	38	6	3	Z6	1	437.0301	12,51
6	50	14	6	Z6	1	437.0601	26,01
8	64	19	6	Z6	1	437.0801	34,39
8	172	19	6	Z6	1	437.0861	52,74
9,6	65	19	6	Z6	1	437.1001	59,73
12,7	77	32	6	Z6	1	437.1301	70,25
12,7	178	32	6	Z6	1	437.1361	68,83
9,6	65	19	6	Z1	1	437.1002	74,68
12,7	77	32	6	Z1	1	437.1302	87,83
8	64	19	6	Z7	1	437.0807	37,86
12,7	77	32	6	Z7	1	437.1307	77,27
8	64	19	6	Z9	1	437.0809	41,28
9,6	65	19	6	Z9	1	437.1009	71,68
12,7	77	32	6	Z9	1	437.1309	84,33



438

Carbide bur, countersink 60°, shape J (KSJ)

Execution: Carbide rotary burrs, 60° countersink shape, in different cuts. Shape J (ISO: KSJ).

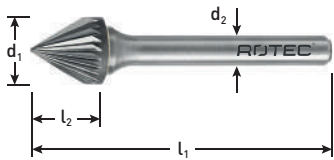

Spiral cut
(Z3)



Double cut
(Z6)



d ₁	l ₁	l ₂	d ₂	Z _f	pcs/PU	Item no.	€ / PU
3	38	2,5	3	Z3	1	438.0305	12,51
9,6	56	8	6	Z3	1	438.1005	29,97
12,7	59	11	6	Z3	1	438.1311	36,40
12,7	59	11	6	Z6	1	438.1301	36,40



438

Carbide bur, countersink 90°, shape K (KSK)

Execution: Carbide rotary burrs, 90° countersink shape, in different cuts. Shape K (ISO: KSK).

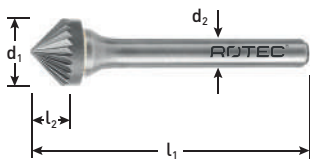

Spiral cut
(Z3)



Double cut
(Z6)



d ₁	l ₁	l ₂	d ₂	Z _f	pcs/PU	Item no.	€ / PU
3	38	1,5	3	Z3	1	438.0315	12,51
6	50	3	6	Z3	1	438.0615	22,88
9,6	53	4,7	6	Z3	1	438.1011	29,97
12,7	55	6,3	6	Z3	1	438.1315	36,40
16	57	8	6	Z3	1	438.1611	48,53
9,6	53	4,7	6	Z6	1	438.1001	29,97
16	57	8	6	Z6	1	438.1601	48,53



439

Carbide bur, ball nosed cone, shape L (KEL)

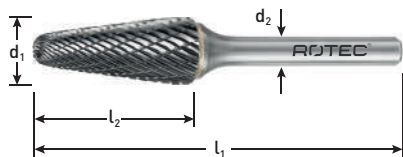

Execution: Carbide rotary burrs, ball nosed cone shape, in different cuts. Shape L (ISO: KEL).

Double cut (Z6)

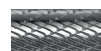

d ₁	l ₁	l ₂	d ₂	Z _f	pcs/PU	Item no.	€ / PU
6	50	18	6	Z6	1	439.0601	26,59
8	70	25,4	6	Z6	1	439.0801	34,90
10	65	20	6	Z6	1	439.1001	41,90
9,6	76	30	6	Z6	1	439.1011	41,90
9,6	183	30	6	Z6	1	439.1061	67,49
12,7	77	32	6	Z6	1	439.1301	51,22
12,7	185	32	6	Z6	1	439.1361	75,94
16	78	33	6	Z6	1	439.1601	100,82

Spiral cut (Z3)



8	70	25,4	6	Z3	1	439.0805	34,90
9,6	76	30	6	Z3	1	439.1005	41,90
12,7	77	32	6	Z3	1	439.1305	51,22

ALU-cut (Z1)



9,6	76	30	6	Z1	1	439.1012	52,55
12,7	77	32	6	Z1	1	439.1302	64,17

STEEL-cut (Z7)



10	65	20	6	Z7	1	439.1007	46,15
12,7	77	32	6	Z7	1	439.1307	56,36

INOX-cut (Z9)



8	70	25,4	6	Z9	1	439.0809	41,90
10	65	20	6	Z9	1	439.1009	50,37
12,7	77	32	6	Z9	1	439.1309	61,50



440

Carbide bur, cone, shape M (SKM)

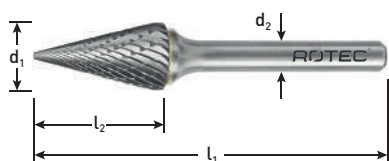

Execution: Carbide rotary burrs, cone shape, in different cuts. Shape M (ISO: SKM).

Double cut (Z6)

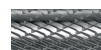

d ₁	l ₁	l ₂	d ₂	Z _f	pcs/PU	Item no.	€ / PU
6,3	49	12,7	3	Z6	1	440.0601	20,52
6	50	20	6	Z6	1	440.0611	26,59
9,6	64	16	6	Z6	1	440.1001	42,04
12,7	71	19	6	Z6	1	440.1301	52,60

ALU-cut (Z1)



9,6	64	16	6	Z1	1	440.1002	52,48
12,7	71	22	6	Z1	1	440.1302	65,80



441

Carbide bur, inverted cone, shape N (WKN)

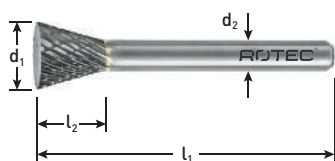

Execution: Carbide rotary burrs, inverted cone shape, in different cuts. Shape N (ISO: WKN).

Double cut (Z6)

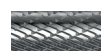

d ₁	l ₁	l ₂	d ₂	Z _f	pcs/PU	Item no.	€ / PU
3	38	4	4	Z6	1	441.0301	12,51
6	50	8	6	Z6	1	441.0601	25,40
12,7	58	12,7	6	Z6	1	441.1301	52,42



442

Carbide burr, multi-edge, shape X

ROTEC®

Execution: Single cut multi-edge carbide burr with X-design assures perfect guidance along the edges. Can be used on a wide range of materials such as cast iron, cast steel, brass, stainless steel etc.

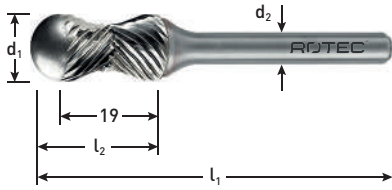

d ₁	l ₁	l ₂	d ₂	Z _f	pcs/PU	Item no.	€ / PU
12,7	70	25	6	Z3	1	442.2000	86,94

X
Shape

443

Carbide burr, combi, shape DN

ROTEC®

Execution: Single cut carbide Combi-burr combines inverted cone and ball shape into one. Result is a very versatile tool that can be used in many different applications and on a wide range of materials such as cast iron, cast steel, brass, bronze, stainless steel etc.

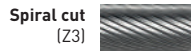
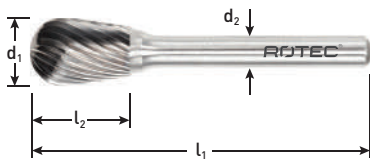

d ₁	l ₁	l ₂	d ₂	Z _f	pcs/PU	Item no.	€ / PU
12,7	63	20	6	Z6	1	443.1300	61,30

DN
Shape

900

Carbide mini-burr set, in plastic case

ROTEC®

Execution: Miniature carbide burrs, DC (Double cut), shank ø3mm



Double cut
The most versatile cut for rotary burrs. Suitable for almost all applications.

Z6
Universal

Description	Content	Toothing	pcs/PU	Item no.	€ / PU
10 pc set carbide burrs ø3 / Z6	Shape A, B, C, D, E, F, G, H, L and M / 1 piece each	[Z6] Double cut	1	900.3060	135,49

Carbide bur set, 5 pc set, in plastic case



Z6
Universal



Double cut
The most versatile cut for rotary burrs. Suitable for almost all applications.

Z3
Spiral



Single cut
Single spiral cut for the best finishes. Very wide application range.

Z1
ALU



ALU-cut
Sharp geometry and wide chip gullets, specifically for aluminium and other non-ferrous metals.

Z7
STEEL



STEEL-cut
Newly developed cut specifically for steels and cast steels. Achieve very high metal removing rates with excellent tool life!

Z9
INOX



INOX-cut
Newly developed cut specifically for stainless steels offering high metal removing rates, excellent surface finishes and tool life!

Description	Content	Toothing	pcs/PU	Item no.	€ / PU
5 pc set carbide burrs ø9,6 / Z6	Shape B, C, F, G and L / 1 piece each	[Z6] Double cut	1	900.3061	184,24
5 pc set carbide burrs ø9,6 / Z3	Shape B, C, F, G and L / 1 piece each	[Z3] Single cut	1	900.3062	186,44
5 pc set carbide burrs ø9,6 / Z1	Shape B, C, F, G and L / 1 piece each	[Z1] ALU-cut	1	900.3063	243,10
5 pc set carbide burrs ø9,6 / Z7	Shape A, C, F, G and L / 1 piece each	[Z7] STEEL-cut	1	900.3064	198,28
5 pc set carbide burrs ø9,6 / Z9	Shape A, C, F, G and L / 1 piece each	[Z9] INOX-cut	1	900.3065	215,16
5 pc set carbide burrs ø12,7 / Z6	Shape B, C, F, G and L / 1 piece each	[Z6] Double cut	1	900.3066	257,76
5 pc set carbide burrs ø12,7 / Z3	Shape B, C, F, G and L / 1 piece each	[Z3] Single cut	1	900.3067	257,76
5 pc set carbide burrs ø12,7 / Z1	Shape B, C, F, G and L / 1 piece each	[Z1] ALU-cut	1	900.3068	319,96
5 pc set carbide burrs ø12,7 / Z7	Shape A, C, F, G and L / 1 piece each	[Z7] STEEL-cut	1	900.3069	277,29
5 pc set carbide burrs ø12,7 / Z9	Shape A, C, F, G and L / 1 piece each	[Z9] INOX-cut	1	900.3070	301,40

Carbide bur set, 10 pc set, in plastic case



Double cut
The most versatile cut for rotary burrs. Suitable for almost all applications.

Z6
Universal

Description	Content	Toothing	pcs/PU	Item no.	€ / PU
10 pc set carbide burrs ø9,6 and ø12,7 / Z6	Shape B, C, F, G and L / 1 piece each	[Z6] Double cut	1	900.3071	405,50
10 pc set carbide burrs ø12,7 / Z6	Shape A, B, C, D, E, F, G, H, L and M / 1 piece each	[Z6] Double cut	1	900.3072	507,61

431

Carbide bur 'GreenCoat', shape B (ZYA-S)

ROTEC®

Execution: Carbide rotary burrs, cylinder shape, with end cut, in different cuts. Shape B (ISO: ZYA-S).

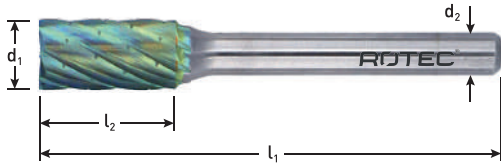

'GreenCoat' double cut with chipbreaker (Z6X)



B

Shape

Z6X

Universal



d_1	l_1	l_2	d_2	Z_f	pcs/PU	Item no.	€ / PU
9,6	64	19	6	Z6X	1	431.1006	43,59

432

Carbide bur 'GreenCoat', shape C (WRC)

ROTEC®

Execution: Carbide rotary burrs, cylinder shape, with ball nose, in different cuts. Shape C (ISO: WRC).

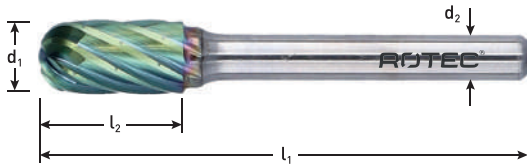

'GreenCoat' double cut with chipbreaker (Z6X)



C

Shape

Z6X

Universal



d_1	l_1	l_2	d_2	Z_f	pcs/PU	Item no.	€ / PU
9,6	64	19	6	Z6X	1	432.1006	44,12

435

Carbide bur 'GreenCoat', shape F (RBF)

ROTEC®

Execution: Carbide rotary burrs, ball nosed tree shape, in different cuts. Shape F (ISO: RBF).



'GreenCoat' double cut with chipbreaker (Z6X)



F

Shape

Z6X

Universal



d_1	l_1	l_2	d_2	Z_f	pcs/PU	Item no.	€ / PU
9,6	64	19	6	Z6X	1	435.1006	43,10

436

Carbide bur 'GreenCoat', shape G (RBG)

ROTEC®

Execution: Carbide rotary burrs, pointed tree shape, in different cuts. Shape G (ISO: RBG).



'GreenCoat' double cut with chipbreaker (Z6X)



G

Shape

Z6X

Universal



d_1	l_1	l_2	d_2	Z_f	pcs/PU	Item no.	€ / PU
9,6	64	19	6	Z6X	1	436.1006	46,06

439 Carbide bur 'GreenCoat', shape L (KEL)

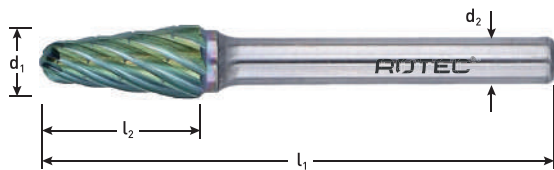

Execution: Carbide rotary burrs, ball nosed cone shape, in different cuts. Shape L (ISO: KEL).

d ₁	l ₁	l ₂	d ₂	Z _f	pcs/PU	Item no.	€ / PU
10	65	20	6	Z6X	1	439.1006	55,12

'GreenCoat' double cut with chipbreaker (Z6X) 



900 'GreenCoat' carbide bur set, 5 pc set



'GreenCoat'
double cut with chipbreaker
Latest geometry and
'GreenCoat' coating for a

- more than twice the material removal rate compared to other carbide burs with conventional double cut
- long(er) high-performance tool life
- problem-free cutting of cast iron, (stainless) steel and Ni-based steels



Description	Content	Toothing	pcs/PU	Item no.	€ / PU
5 pc set carbide burrs ø9,6 / Z6	Shape B, C, F, G and L / 1 piece each	[Z6X] Double cut	1	900.3073	239,78

445

Carbide bur 'OPTI-LINE', shape A (ZYA)

Execution: Carbide rotary burrs, cylinder shape, without end cut. Shape A (ISO: ZYA).

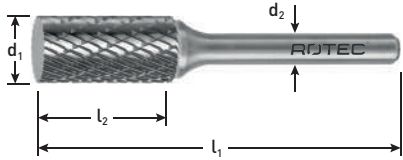

d ₁	l ₁	l ₂	d ₂	Z _f	pcs/PU	Item no.	€ / PU
6	50	18	6	Z6	1	445.01.0601	18,08
8	64	19	6	Z6	1	445.01.0801	17,05
9,6	64	19	6	Z6	1	445.01.1001	22,14
12,7	70	25	6	Z6	1	445.01.1301	34,02

A Shape **Z6** Universal **OPTI**

Carbide bur 'OPTI-LINE', shape B (ZYA-S)

Execution: Carbide rotary burrs, cylinder shape, with end cut. Shape B (ISO: ZYA-S).

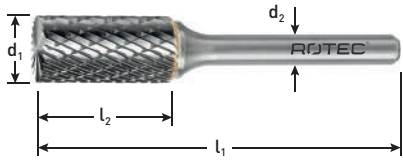

d ₁	l ₁	l ₂	d ₂	Z _f	pcs/PU	Item no.	€ / PU
6	50	18	6	Z6	1	445.02.0601	18,72
8	64	19	6	Z6	1	445.02.0801	17,71
9,6	64	19	6	Z6	1	445.02.1001	23,08
12,7	70	25	6	Z6	1	445.02.1301	35,32

B Shape **Z6** Universal **OPTI**

Carbide bur 'OPTI-LINE', shape C (WRC)

Execution: Carbide rotary burrs, cylinder shape, with ball nose. Shape C (ISO: WRC).

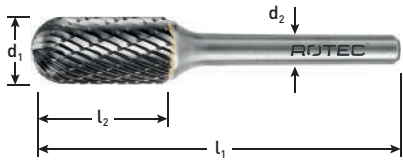

d ₁	l ₁	l ₂	d ₂	Z _f	pcs/PU	Item no.	€ / PU
6	50	18	6	Z6	1	445.03.0601	19,35
6	60	19	6	Z6	1	445.03.0601-060	20,82
8	64	19	6	Z6	1	445.03.0801	15,78
10,0	64	19	6	Z6	1	445.03.1001	21,62
12,7	70	25	6	Z6	1	445.03.1301	32,85

C Shape **Z6** Universal **OPTI**

Carbide bur 'OPTI-LINE', for locksmiths

Execution: Carbide rotary burrs, cylinder shape, with ball nose. Shape C (ISO: WRC).

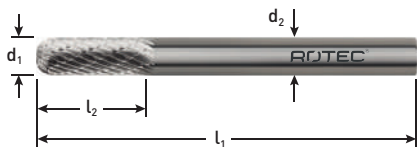

d ₁	l ₁	l ₂	d ₂	Z _f	pcs/PU	Item no.	€ / PU
6	50	18	6	Z6	1	445.03.0601	19,35
6	60	19	6	Z6	1	445.03.0601-060	20,82



C Shape **Z6** Universal **OPTI**

Carbide bur 'OPTI-LINE', shape F (RBF)

Execution: Carbide rotary burrs, ball nosed tree shape. Shape F (ISO: RBF).

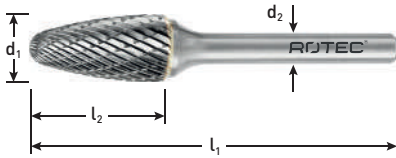

d ₁	l ₁	l ₂	d ₂	Z _f	pcs/PU	Item no.	€ / PU
6	50	18	6	Z6	1	445.06.0601	19,98
8	65	20	6	Z6	1	445.06.0801	15,39
9,6	64	19	6	Z6	1	445.06.1001	17,43
12,7	70	25	6	Z6	1	445.06.1301	35,34

F
Shape

Z6
Universal

OPTI

Carbide bur 'OPTI-LINE', shape G (RBG)

Execution: Carbide rotary burrs, pointed tree shape. Shape G (ISO: RBG).

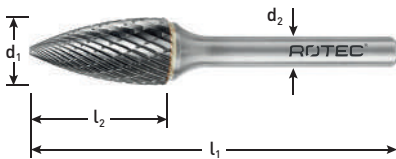

d ₁	l ₁	l ₂	d ₂	Z _f	pcs/PU	Item no.	€ / PU
6	50	18	6	Z6	1	445.07.0601	19,98
8	64	19	6	Z6	1	445.07.0801	17,06
9,6	64	19	6	Z6	1	445.07.1001	17,51
12,7	64	25	6	Z6	1	445.07.1301	31,75

G
Shape

Z6
Universal

OPTI

Carbide bur 'OPTI-LINE', shape L (KEL)

Execution: Carbide rotary burrs, ball nosed cone shape. Shape L (ISO: KEL).

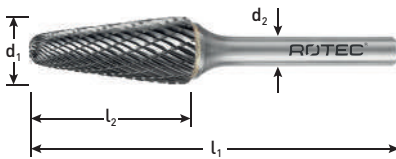

d ₁	l ₁	l ₂	d ₂	Z _f	pcs/PU	Item no.	€ / PU
6	50	18	6	Z6	1	445.11.0601	20,61
8	70	25,4	6	Z6	1	445.11.0801	17,86
10	65	20	6	Z6	1	445.11.1001	22,37
12,7	77	32	6	Z6	1	445.11.1301	27,44

L
Shape

Z6
Universal

OPTI

Carbide bur 'OPTI-LINE', shape M (SKM)

Execution: Carbide rotary burrs, cone shape. Shape M (ISO: SKM).

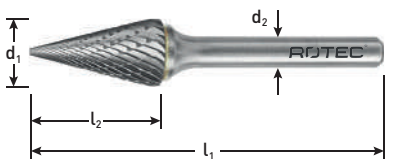

d ₁	l ₁	l ₂	d ₂	Z _f	pcs/PU	Item no.	€ / PU
6,3	49	12,7	3	Z6	1	445.12.0601	18,55
9,6	64	16	6	Z6	1	445.12.1001	18,93
12,7	71	19	6	Z6	1	445.12.1301	23,03

M
Shape

Z6
Universal

OPTI



Description	Content	Toothing	pcs/PU	Item no.	€ / PU
10 pc set carbide burrs $\varnothing 9,6$ and $\varnothing 12,7$ / Z6	Shape B, C, F, G and L / 1 piece each per diameter	[Z6] Double cut	1	445.99.0100	217,10

450

Hand deburrer type EL1100GT

Application: GT "B" set, voor universeel gebruik o.a. metaal en kunststof.

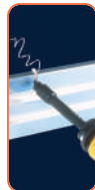

Type	Content	pcs/PU	Item no.	€ / PU
EL1100GT	EL1000GT, B10 en B20	1	450.1000	20,44

Application: GT "E" set, universeel gebruik, voor stevig ontbramen.



Type	Content	pcs/PU	Item no.	€ / PU
EL1200GT	EL1000GT, EL0200GT, E100, E200 E300	1	450.1002	21,21

Application: Voor ontbramen en verzinken van boringen.



Type	Content	pcs/PU	Item no.	€ / PU
EL1300GT	EL1000GT, EL0300GT, C20	1	450.1004	50,24

Application: GT-Maxi-driekantschraper.



Type	Content	pcs/PU	Item no.	€ / PU
EL1601GT	EL1000GT, EL0602GT, T60	1	450.1008	34,69

Application: GT-medium-driekantschraper.



Type	Content	pcs/PU	Item no.	€ / PU
EL1600GT	EL1600GT EL0602GT, T40	1	450.1010	30,77

Application: Plaatontbramer "GT-V": een gunstig en praktisch gereedschap voor ontbramen van plaatmateriaal tussen 1 en 8 mm.



Type	Content	pcs/PU	Item no.	€ / PU
EL1703GT	EL1000GT, EL0701GT, L3	1	450.1022	29,84

Application: Compact-set "GTK": de universele ontbramer!



Type	Content	pcs/PU	Item no.	€ / PU
EL6000GT	EL2100GT, E100, E200, E300	1	450.1024	16,86



Application: Dubbele plaatontbramer: voor dubbelzijdig ontbramen van plaatmateriaal dikte 0-12 mm. Met kunststof handgreep en beschermkap.

Type	Content	pcs/PU	Item no.	€ / PU
DB2000GT	DB-holder + blades GT-N80	1	450.1028	32,89



Application: Snelontbramer. Handzaam ontbraam gereedschap met uitwisselbaar mesje. Zeskant-aluminium handgreep 12 mm met meshouder van staal.

Type	Content	pcs/PU	Item no.	€ / PU
RB1000GT	Hex. 12mm handle, E100	1	450.1030	13,14



Application: Universeel gereedschap met niet uitwisselbare mesje. Zeskant-aluminium handgreep 8 mm met cliphouder.

Type	Content	pcs/PU	Item no.	€ / PU
E01000GT	Hex. 8mm handle, E100	1	450.1032	9,72



Application: Ergonomische softgrip handgreep voor "E" en "B" mesjes.

Type	Content	pcs/PU	Item no.	€ / PU
SG1000GT	Holder SG3000GT, E100S, B10S	1	450.1056	22,74



Application: Deburr both inside and outside edges of tubes. Have 3 cutters. Reamer for aluminum, brass and copper tubing. Made of plastic.

Type	Content	pcs/PU	Item no.	€ / PU
SP81003		1	450.1096	10,35



Application: Mini set "GT-Mini" bestaande uit 3 handontbramers.

Type	Content	pcs/PU	Item no.	€ / PU
FT3000GT	1x FT1200GT (450.1060), 1x FT1100GT (450.1062) and 1x FT1000GT (450.1064)	1	450.1065	34,74



Application: Ideaal voor gelijktijdig ontbramen van beide zijden van het werkstuk.

Type	Content	pcs/PU	Item no.	€ / PU
DB5000	DB holder and V-blade 1-11 mm	1	450.1074	58,23

Hand deburrers set type SG2001GT

GRATTEC



Application: Ergonomische softgrip handgreep met super harde B10 en E100 cobalt mesjes voor roestvaststaal en kunststoffen.

Type	Content	pcs/PU	Item no.	€ / PU
SG2001GT	SG3000GT, 11 x E100S, 11 x B10S	1	450.1081	59,75

Grip type SG3000GT for hand deburrers

GRATTEC



Execution: Ergonomische handgreep met softgrip.
Application: Bestemd voor "E" en "B" mesjes.

Type	pcs/PU	Item no.	€ / PU
SG3000GT	1	450.1102	17,19



Execution: Universele handgreep voor alle mesjes/houders. Voorzien van ruimte voor reserve mesjes.

Type	pcs/PU	Item no.	€ / PU
EL1000GT	1	450.1108	10,77

Holder type EL0100GT for deburrers

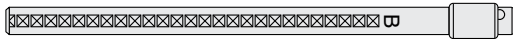

Execution: B-houder. Houder voor mesjes type B (ø 2,6 mm). Lengte 131 mm. Mesje kan 90° worden gedraaid voor het ontbramen van kruisende gaten.

Type	pcs/PU	Item no.	€ / PU
EL0100GT	1	450.1110	9,89



Execution: E-houder. Houder voor mesjes type E (ø 3,2 mm). Lengte 131 mm.

Type	pcs/PU	Item no.	€ / PU
EL0200GT	1	450.1114	9,89



Execution: C-houder. Houder voor mesjes type C met M7 uitwendige draad.

Type	pcs/PU	Item no.	€ / PU
EL0300GT	1	450.1116	9,89



Execution: D-houder, Houder voor GT-D50 en GT-D66 schrapers. Een 3 mm schroefje zorgt voor de borging van het mesje.

Type	pcs/PU	Item no.	€ / PU
EL0500GT	1	450.1120	11,99



Execution: T-Houder. Houder voor GT-T40 en GT-T60 ontbraammesjes.

Type	pcs/PU	Item no.	€ / PU
EL0602GT	1	450.1122	9,89

Blade type GT-B10 for hand deburrers



B10 **HSS** 
R

Application: HSS mesje voor normale ontbraamwerkzaamheden in staal, aluminium en kunststof (ø 2,6 mm).

Type	pcs/PU	Item no.	€ / PU
GT-B10	10	450.5000	21,94



B10 **HSS** 
L

Application: B10L mesje voor linkshandige gebruiker.

Type	pcs/PU	Item no.	€ / PU
GT-B10L *	1	450.5001	3,31

* Phase-out item, available until stock has depleted



B10 **HSS** 
Co R

Application: Super hard B10 (Cobalt) mesje voor roestvaststaal en kunststoffen.

Type	pcs/PU	Item no.	€ / PU
GT-B10S	10	450.5002	24,72



B10 **HSS** 
TiN R

Application: B10 TiN coating voor langere standtijd.

Type	pcs/PU	Item no.	€ / PU
GT-B10 TiN	10	450.5004	52,74



B10 **SC** 
Ultra-Fine R

Application: B10 in volhardmetaal voor gehard staal en diverse kunststoffen.

Type	pcs/PU	Item no.	€ / PU
GT-B10C *	1	450.5008	9,97

* Phase-out item, available until stock has depleted



B20 **SC** 
Ultra-Fine R

Application: Volhardmetaal B20 mesje voor gehard staal en harde kunststoffen.

Type	pcs/PU	Item no.	€ / PU
GT-B20C *	1	450.5012	20,92

* Phase-out item, available until stock has depleted



B30 **HSS** 
R

Application: HSS mesje voor het gelijktijdig verwijderen van binnen- en buitenbramen.

Type	pcs/PU	Item no.	€ / PU
GT-B30	10	450.5014	34,71



B60 **HSS** 
R

Application: HSS mesje voor dwarsboringen op moeilijk te bereiken plaatsen.

Type	pcs/PU	Item no.	€ / PU
GT-B60 *	1	450.5016	9,67

* Phase-out item, available until stock has depleted



E100 **HSS** 
R

Application: HSS mesje voor moeilijke ontbraamwerkzaamheden in staal, aluminium en kunststof (ø 3,2 mm).

Type	pcs/PU	Item no.	€ / PU
GT-E100	10	450.5018	21,94



Application: E100 voor linkshandige gebruikers.

Type	pcs/PU	Item no.	€ / PU
E100L	10	450.5020	40,48

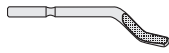

Application: E100 TiN coating voor langere standtijd.

Type	pcs/PU	Item no.	€ / PU
GT-E100T	10	450.5022	54,90



Application: HSS-E mesje voor slijtvastheid.

Type	pcs/PU	Item no.	€ / PU
GT-E100S	10	450.5028	25,75

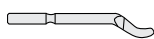

Application: HSS mesje met heavy duty schacht en fijne snijhoek voor staal en aluminium.

Type	pcs/PU	Item no.	€ / PU
GT-E101 *	10	450.5030	28,84

* Phase-out item, available until stock has depleted



Application: E101 mesje voor linkshandige gebruikers.

Type	pcs/PU	Item no.	€ / PU
GT-E101L *	10	450.5032	39,24

* Phase-out item, available until stock has depleted



Application: E101 TiN gecoat mesje voor extra lange levensduur.

Type	pcs/PU	Item no.	€ / PU
GT-E101T	10	450.5034	54,90



Application: HSS mesje voor moeilijke ontbraamwerkzaamheden in messing en gietijzer. Voor links- en rechtshandig gebruik.

Type	pcs/PU	Item no.	€ / PU
GT-E200	10	450.5038	21,94



Application: Volhardmetaal E200 mesje voor geharde materialen en kunststoffen.

Type	pcs/PU	Item no.	€ / PU
GT-E200C *	10	450.5039	111,14

* Phase-out item, available until stock has depleted



Application: HSS mesje voor gelijktijdig verwijderen van sterke binnen- en buitenbramen in boringen van plaatmaterialen en buizen.

Type	pcs/PU	Item no.	€ / PU
GT-E300	10	450.5044	29,97



Application: HSS mesje voor sterke bramen op gelijke kanten.

Type	pcs/PU	Item no.	€ / PU
GT-E350	10	450.5046	29,97



Application: HSS mesje voor sterke bramen op dwarsboringen.

Type	pcs/PU	Item no.	€ / PU
GT-E600 *	10	450.5048	105,16

* Phase-out item, available until stock has depleted



Application: HSS 90° verzinker ø 12 mm.

Type	pcs/PU	Item no.	€ / PU
GT-C12 *	1	450.5100	26,76

* Phase-out item, available until stock has depleted

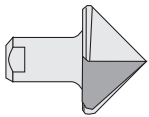

Application: HSS 90° verzinker ø 30 mm.

Type	pcs/PU	Item no.	€ / PU
GT-C30 *	1	450.5104	51,30

* Phase-out item, available until stock has depleted



Application: Gepatenteerd HSS slinger mesje t.b.v. RotoDrive verzinker diameter 0-3 mm.

Type	pcs/PU	Item no.	€ / PU
GT BC3200 *	1	450.5106	18,29

* Phase-out item, available until stock has depleted

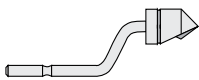

Application: Gepatenteerd HSS slinger mesje t.b.v. RotoDrive verzinker diameter 0-10,4 mm.

Type	pcs/PU	Item no.	€ / PU
GT BC1040 *	1	450.5112	23,91

* Phase-out item, available until stock has depleted

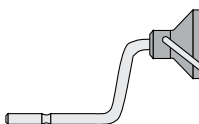

Application: Gepatenteerd HSS slinger mesje uitwendige verzinker 4-18 mm.

Type	pcs/PU	Item no.	€ / PU
GT EX2000 *	1	450.5116	23,06

* Phase-out item, available until stock has depleted

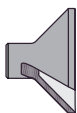

Application: Gepatenteerd HSS slinger mesje 28 mm uitwendige verzinker 8-28 mm.

Type	pcs/PU	Item no.	€ / PU
GT EX3001 *	1	450.5118	52,75

* Phase-out item, available until stock has depleted



Application: Voor plaatmateriaal 1-8 mm breed.

Type	pcs/PU	Item no.	€ / PU
GT-L1 *	1	450.5200	3,31

* Phase-out item, available until stock has depleted



D50 HSS

Application: HSS driekantschraper 3,2 x 50 mm voor fijne ontbraam werkzaamheden. Past in de houders EL0500GT en HB1000.

Type	pcs/PU	Item no.	€ / PU
GT-D50	10	450.5300	126,69



D55 SC Ultra-Fine

Application: Volhardmetaal GT-D50 mesje voor D-houder EL0500GT.

Type	pcs/PU	Item no.	€ / PU
GT-D55 *	1	450.5302	28,69

* Phase-out item, available until stock has depleted



T40 HSS

Application: Driekantschraper 5 x 40 mm. Past in de houders EL0602GT en HS2000.

Type	pcs/PU	Item no.	€ / PU
GT-T40 *	1	450.5306	12,50

* Phase-out item, available until stock has depleted



T60 HSS

Application: Driekantschraper 7 x 60 mm. Past in de houders EL0602GT en HS2000.

Type	pcs/PU	Item no.	€ / PU
GT-T60	1	450.5308	18,59



D66 HSS

Application: Haaks gebogen HSS driekantschraper 3,2 x 50 mm voor binnenkant van dwarsboringen. Past in de houders EL0500GT en HB1000.

Type	pcs/PU	Item no.	€ / PU
GT-D66 *	10	450.5310	93,32

* Phase-out item, available until stock has depleted



N80 HSS

Application: Ronde snijmesjes voor dubbel ontbramen. De snijkant is over de hele omvang aan beide zijden. Lange standtijd.

Type	pcs/PU	Item no.	€ / PU
GT-N80	10	450.5400	79,00



N80 M42

Application: Zoals de GT-N80, echter op HRc 68 gehard. Voor roestvaststaal.

Type	pcs/PU	Item no.	€ / PU
GT-N80M4	10	450.5402	102,28

TCT Stud deburrer



Execution: TCT stud deburrer with 1/4" bit shank E6.3 for use in cordless drills.

Application: Suitable for effortless deburring of thread studs with diameters from ø3 to ø20 mm. Also suitable for chamfering pipes, bolts and various other round objects made of steel, stainless steel, cast iron, copper, plastic, etc.

d (min-max)	D (mm)	L (mm)	pcs/PU	Item no.	€ / PU
ø3-20	28	67	1	450.1095	36,00

451

Scriber, in EV-pack

ROTEC®



Execution: Hexagonal shank and CBN precision ground carbide tip.

Type	l ₁	pcs/PU	Item no.	€ / PU
Hex.	150	1	451.0000	3,99

455

Utility knife, Premium

ROTEC®



Application: Premium quality retractable blade utility knife for professionals. The ergonomically designed firm metal handle with anti-slip pad can be opened with a slider on the side. The handle provides storage for spare blades. Exchange blades without tools! Including 2 blades type 1992.

Type	Blades incl.	pcs/PU	Item no.	€ / PU
Premium	2	1	455.0001	23,21

Utility knife, Standard

ROTEC®



Application: Retractable blade utility knife with firm metal handle. The handle provides storage for spare blades. Exchange blades without tools! Including 2 blades type 1992.

Type	Blades incl.	pcs/PU	Item no.	€ / PU
Standard	2	1	455.1001	10,11

Safety knife

ROTEC®



Application: Safety retractable utility blade knife with firm metal handle. The handle provides storage for spare blades. Exchange blades without tools! The blade is extended by operating the slider with the thumb. When the slider is released, the blade automatically retracts into the handle. Including 2 blades type 1992.

Type	Blades incl.	pcs/PU	Item no.	€ / PU
Safety	2	1	455.1003	10,87

Snap-off knife

ROTEC®



Application: Premium quality retractable snap-off utility knife for professionals. Firm metal handle with locking mechanism and blade storage. Including 3 blades (9mm height)

Type	Blades incl.	pcs/PU	Item no.	€ / PU
Premium 9 mm	3	1	455.2001	13,45



Application: Premium quality retractable snap-off utility knife for professionals. Firm metal handle with locking mechanism and blade storage. Including 3 blades (18mm height)

Type	Blades incl.	pcs/PU	Item no.	€ / PU
Premium 18 mm	3	1	455.2003	21,25

456

Snap-off utility knives, 18mm, OPTI-LINE



Execution: Stainless steel retractable utility safety knife for 18mm snap-off blades, impact-resistant ABS grip, including 1 blade with 15 segments.

Remark: Packed per 24 pcs in a carton display.

Type	📦	pcs/PU	Item no.	€ / PU
OPTI-LINE 18 mm	24	1	456.0005	3,36



Execution: Stainless steel retractable utility safety knife for 18mm snap-off blades, impact-resistant ABS 'SOFT-GRIP', including 1 blade with 15 segments.

Packed per 24 pcs in a carton display.

Type	📦	pcs/PU	Item no.	€ / PU
OPTI-LINE 18 mm	24	1	456.0105	4,44



Execution: Stainless steel retractable utility safety knife for 18mm snap-off blades, impact-resistant ABS casing with 'SOFT-GRIP', auto-load system, including 3 blades with 15 segments.

Packed per 12 pcs in a carton display.

Type	📦	pcs/PU	Item no.	€ / PU
OPTI-LINE 18 mm	12	1	456.0205	11,18



Execution: Stainless steel retractable utility safety knife for 18mm snap-off blades, zinc casing, including 1 blade with 15 segments.

Packed per 24 pcs in a carton display.

Type	📦	pcs/PU	Item no.	€ / PU
OPTI-LINE 18 mm	24	1	456.1005	7,31



24x 456.0005



24x 456.0105



12x 456.0205



24x 456.1005

460

Spare blade, straight

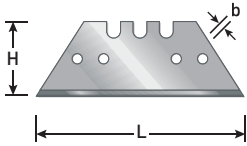

Execution: Blade for professional use in general applications. Short model, regular thickness, ice-hardened steel with 3-facet precision ground cutting edge. Made in Germany. Comparable to Stanley's model 1991. Packed per 5 pieces on a card with handy dispenser.

L (mm)	H (mm)	b	pcs/PU	Item no.	€ / PU
50	19	0,43	5	460.0001	1,38

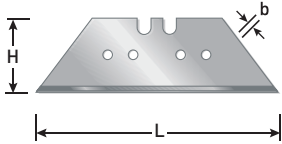

Execution: Blade for professional use in general applications. Long model, extra thick (heavy duty), ice-hardened steel with 3-facet precision ground cutting edge. Made in Germany. Comparable to Stanley's model 1992. Packed per 5 pieces on a card with handy dispenser. Packed per 100 pieces in a tin can.

L (mm)	H (mm)	b	pcs/PU	Item no.	€ / PU
62	19	0,65	5	460.0065	2,19
62	19	0,65	100	460.0070	45,45

Spare hook blade for utility knives, model 1996

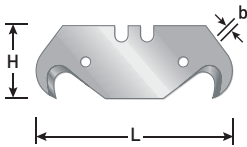

Execution: Hook blade for professional use. Extra thick (heavy duty), ice-hardened steel with 3-facet precision ground cutting edge. Made in Germany. Comparable to Stanley's model 1996. Packed per 5 pieces on a card with handy dispenser. Packed per 100 pieces in a tin can.

L (mm)	H (mm)	b	pcs/PU	Item no.	€ / PU
50	19	0,65	5	460.1005	3,25
50	19	0,65	100	460.1010	65,54

Spare snap-off blade

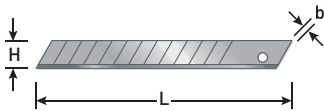

Execution: Snap-off blade for professional use in general applications. Suitable for all 9mm snap-off utility knives. Each blade has 12 segments. Ice-hardened steel with 3-facet precision ground cutting edge. Made in Germany. Packed per 10 pieces on a card with handy dispenser.

L (mm)	H (mm)	b	pcs/PU	Item no.	€ / PU
80	9	0,4	10	460.2001	4,52

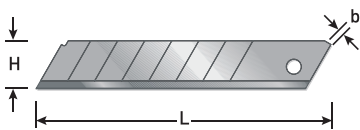

Execution: Snap-off blade for professional use in general applications. Suitable for all 18mm snap-off utility knives. Each blade has 7 segments. Ice-hardened steel with 3-facet precision ground cutting edge. Packed per 10 pieces on a card with handy dispenser. Packed per 100 pieces in a tin can.

L (mm)	H (mm)	b	pcs/PU	Item no.	€ / PU
100	18	0,5	10	460.2010	4,95
100	18	0,5	100	460.2020	55,23

461

Blade for snap-off utility knives 18mm, OPTI-LINE



OPTI



Execution: Snap-off blade for professional use. Suitable for all 18mm snap-off utility knives. Each blade has 15 segments. Ice-hardened steel with 3-facet precision ground cutting edge. 461.0405 : per 10 pcs in a handy reclosable packaging. 461.0406 : per 100 pcs (10 packagings of 10 pcs) in a box.

L (mm)	H (mm)	b	pcs/PU	Item no.	€ / PU
100	18	0,5	10	461.0405	3,87
100	18	0,5	100	461.0406	35,97

465

Pipe cutter, Premium



Application: Mini pipe cutter for professional use. Especially for thin walled pipes made from hard or soft copper, aluminium, brass, plastic, etc. For use in areas with limited working space.

d (min-max)	Type	pcs/PU	Item no.	€ / PU
ø3 - 30	Premium	1	465.0001	23,35

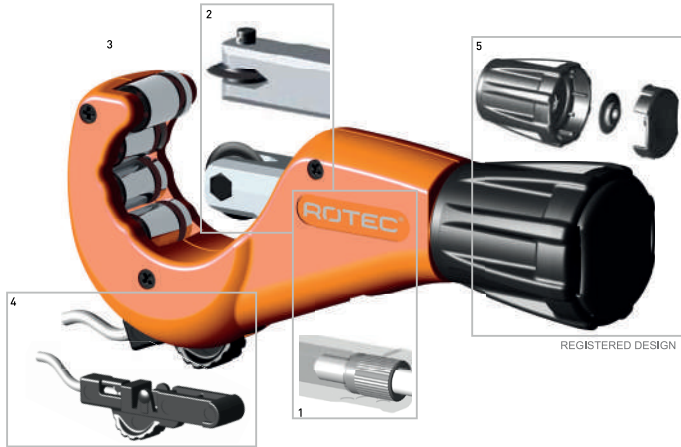

Execution:

1. Spindle with steel bearing
2. Instant-Change-System (ICS) for changing blade without tools
3. Optimized stability due to 4 rollers
4. Removable deburrer
5. Spare blade in knob cap

Application: Pipe cutter for professional use. Feed spindle with steel bearings for fast and easy cutting of pipes made from hard or soft copper, aluminium, brass, plastic, etc. Even for use on thin walled steel pipes.

d (min-max)	Type	pcs/PU	Item no.	€ / PU
ø3 - 35	Premium	1	465.0003	42,06



Application: Pipe cutter for professional use. Feed spindle with steel bearings for fast and easy cutting of pipes made from hard or soft copper, aluminium, brass, plastic, etc. Even for use on thin walled steel pipes. Removable deburring tool and a spare blade in the adjustment knob.

d (min-max)	Type	pcs/PU	Item no.	€ / PU
ø3 - 45	Premium	1	465.0005	46,62



Application: Pipe cutter for professional use with rapid-adjustment. Feed spindle with steel bearings for fast and easy cutting of pipes made from hard or soft copper, aluminium, brass, plastic, etc. Even for use on thin walled steel pipes. Spare blade in the adjustment knob.

d (min-max)	Type	pcs/PU	Item no.	€ / PU
ø6 - 76	Premium	1	465.0007	78,34

Pipe cutter, Standard



Application: Mini pipe cutter in semi-professional quality. Especially for thin walled pipes made from hard or soft copper, aluminium, brass, plastic, etc. For use in areas with limited working space. Spare blade in the adjustment knob.

d (min-max)	Type	pcs/PU	Item no.	€ / PU
ø3 - 16	Standard	1	465.1001	16,25



Application: Pipe cutter in semi-professional quality. Especially for thin walled pipes made from hard or soft copper, aluminium, brass, plastic, etc. For use in areas with limited working space. Spare blade in the adjustment knob.

d (min-max)	Type	pcs/PU	Item no.	€ / PU
ø3 - 30	Standard	1	465.1005	20,65

Spare blade for pipe cutters

Execution: Pipe cutter blades have tight-toleranced cutting edges making them very precise which results in accurate, sharp and smooth cuts.

d (min-max)	Type	pcs/PU	Item no.	€ / PU
ø3 - 45	Blade Universal	1	465.9001	2,42
ø6 - 76	Blade Universal	1	465.9005	2,42
ø3 - 45	Blade Cu/Alu	1	465.9010	2,42
ø6 - 76	Blade Cu/Alu	1	465.9015	2,35
ø3 - 45	Repl. axle	1	465.9020	1,63
ø6 - 76	Repl. axle	1	465.9025	1,75

Pipe deburring tool

Application: Pipe deburring tools for internal and external deburring applications. Plastic casing with 3 hardened steel blades.

d (min-max)	Type	pcs/PU	Item no.	€ / PU
ø4 - 42	SP81003	1	450.1096	10,35

